

MAHTEC

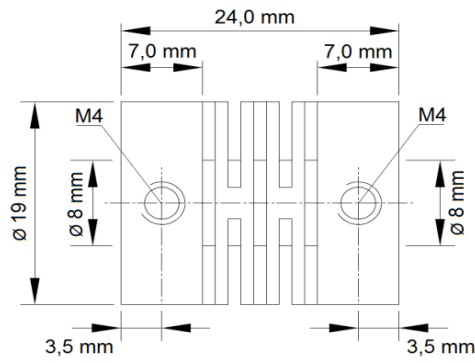

Dimensions



Technical data

Ambient conditions

Operating temperature	-40 ... 85 °C
-----------------------	---------------

Mechanical specifications

Shaft diameter	8 mm
Material	Plastic
Color	Blue
Mass	5 g
Rotational speed	max. 8000 min ⁻¹
Max. Torque	1 Nm
Radial offset	max. ± 0.3 mm
Axial offset	max. ± 0.5 mm
Angle error	max. ± 4 °
Moment of inertia	10 kg m ² x 10 ⁻⁷
Mounting clamp screws	M4 x 6, DIN 916
Mounting clamp screws material	Stainless steel
Tightening torque of clamping screws	max. 0,5 Nm

Model Number

MHT-KPL-BU-8-8

Coupling

Features

- Universally suitable for backlash-free rotation transmission
- Vibration- isolating
- Optimall misalignment compensation
- Medium torsion spring stiffness
- Small reset forces
- No moving parts, fabricated in one piece
- Suitable for vacuum