

# cilindri rotanti

rotary cylinders

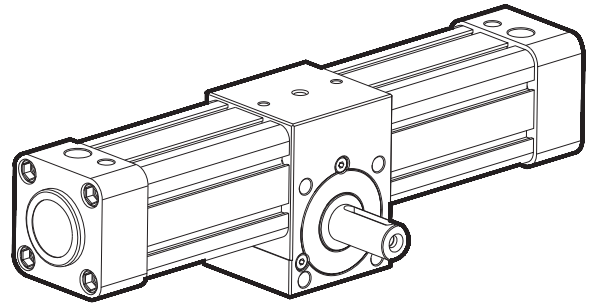

- Grande affidabilità e lunga durata  
*High reliability and long life time*
- Versione magnetica standard  
*Standard magnetic version*
- Sensori magnetici standard (pag. 654-657; 660-661)  
*Standard magnetic sensors (pages 654-657; 660-661)*
- Ammortizzo pneumatico integrato  
*Integrated pneumatic cushioning*

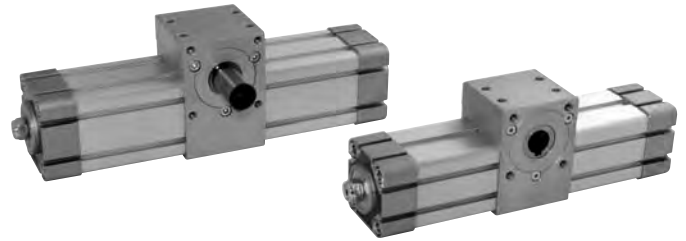

AR M 1 8 0 - 0 3 2

famiglia  
*product family*

pignone  
*pinion*

alesaggio  
*bore*

angolo di rotazione  
*rotation angle*

## Famiglia [product family]

**AR** cilindri rotanti [rotary cylinders]

## Pignone [pinion]

**M** pignone maschio [male pinion]

**F** pignone femmina [female pinion]

Pressione di esercizio <i>Working pressure</i>	max 10 bar max 1 MPa
Temperatura di esercizio <i>Temperature range</i>	max +60°C
Alesaggi <i>Bores</i>	32; 40; 50; 63; 80; 100; 125 mm
Angolo di rotazione <i>Rotation angle</i>	90°; 180°; 270°; 360° regolazione angolo: ±5° [angle adjustment: ±5°]
Fluido <i>Fluid</i>	Aria filtrata 50µ con o senza lubrificazione 50µ filtered, lubricated or non lubricated air

# cilindri rotanti

## rotary cylinders

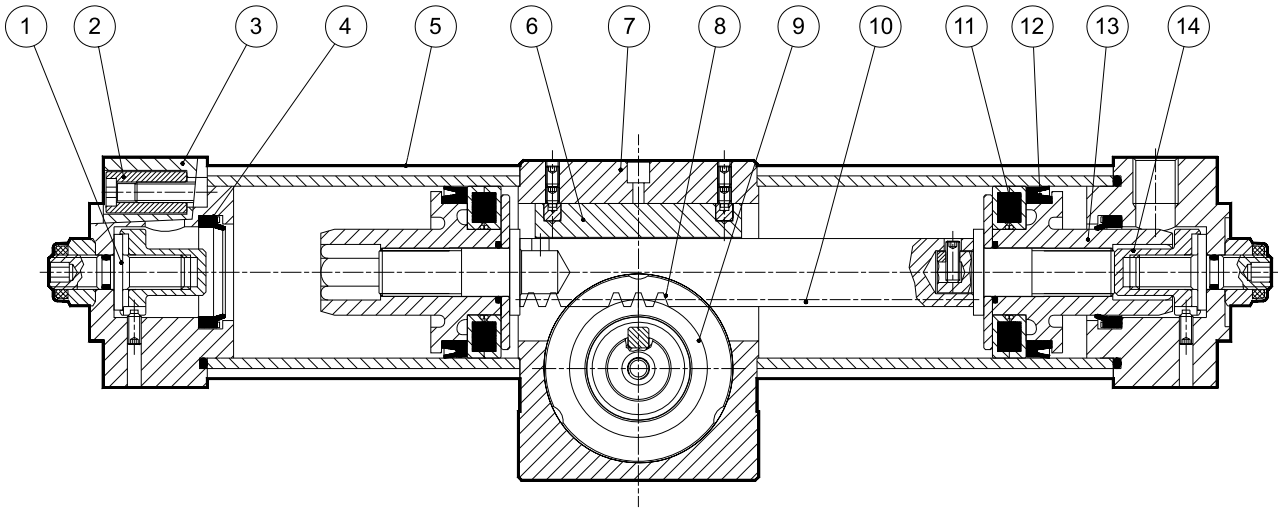

- |   |  |
|---|--|
| 1. Vite di regolazione: acciaio zincato                 | 8. Pignone: acciaio nitrurato                |
| 2. Vite per fissaggio testata: acciaio zincato          | 9. Cuscinetto a sfera                        |
| 3. Testata cilindro: alluminio pressofuso               | 10. Cremagliera: acciaio normalizzato        |
| 4. Guarnizione ammortizzo: NBR                          | 11. Anello magnetico: plastoferrite          |
| 5. Camicia: estruso in lega alluminio anodizzato        | 12. Guarnizione pistone: NBR                 |
| 6. Piattino di guida cremagliera: resina acetica Delrin | 13. Pistone: alluminio pressofuso            |
| 7. Corpo cilindro rotante: alluminio anodizzato         | 14. Vite bloccaggio pistone: acciaio zincato |

6

Massimo carico radiale F1 con F=0  
Maximum radial load F1 with F=0

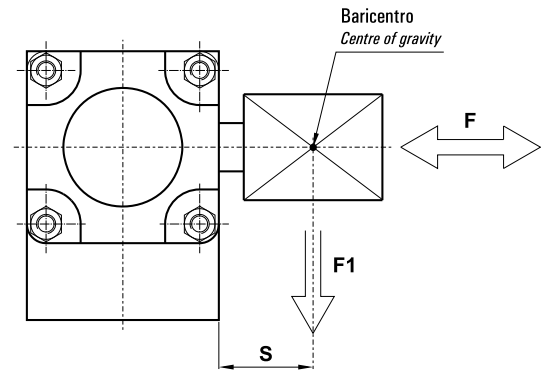
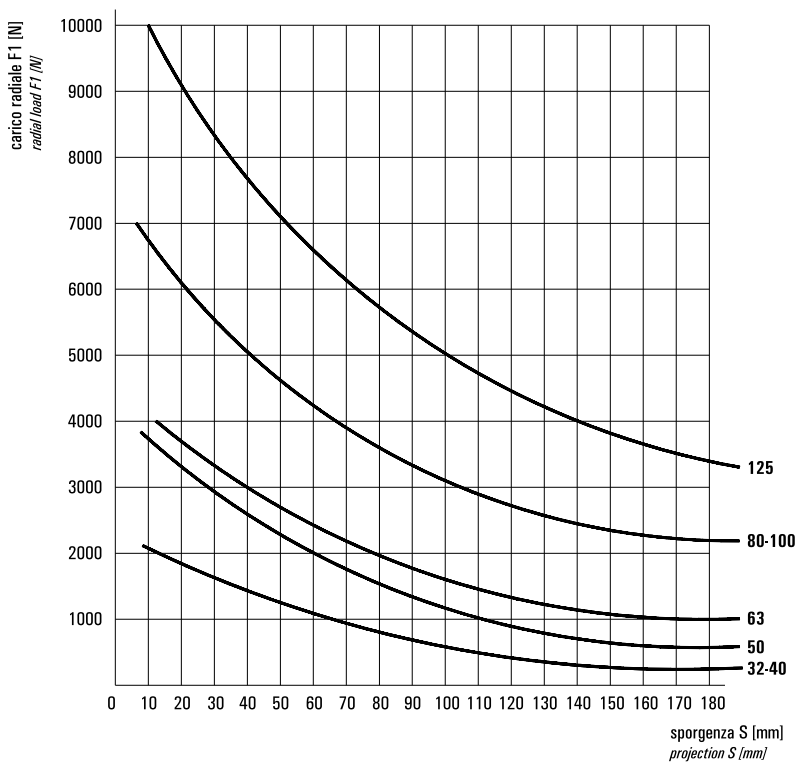

Massimo carico assiale F con F1=0  
Maximum axial load F with F1=0

alesaggio bore	F
32	100 N
40	100 N
50	120 N
63	120 N
80	200 N
100	250 N
125	300 N

Momento torcente Torque

alesaggio bore	M (1 bar)	M (6 bar)
32	1.2 Nm	7.2 Nm
40	2.25 Nm	13.5 Nm
50	3.9 Nm	23.4 Nm
63	7.3 Nm	43.8 Nm
80	15.7 Nm	94.2 Nm
100	26.35 Nm	158.1 Nm
125	51 Nm	306 Nm

# cilindri rotanti

rotary cylinders

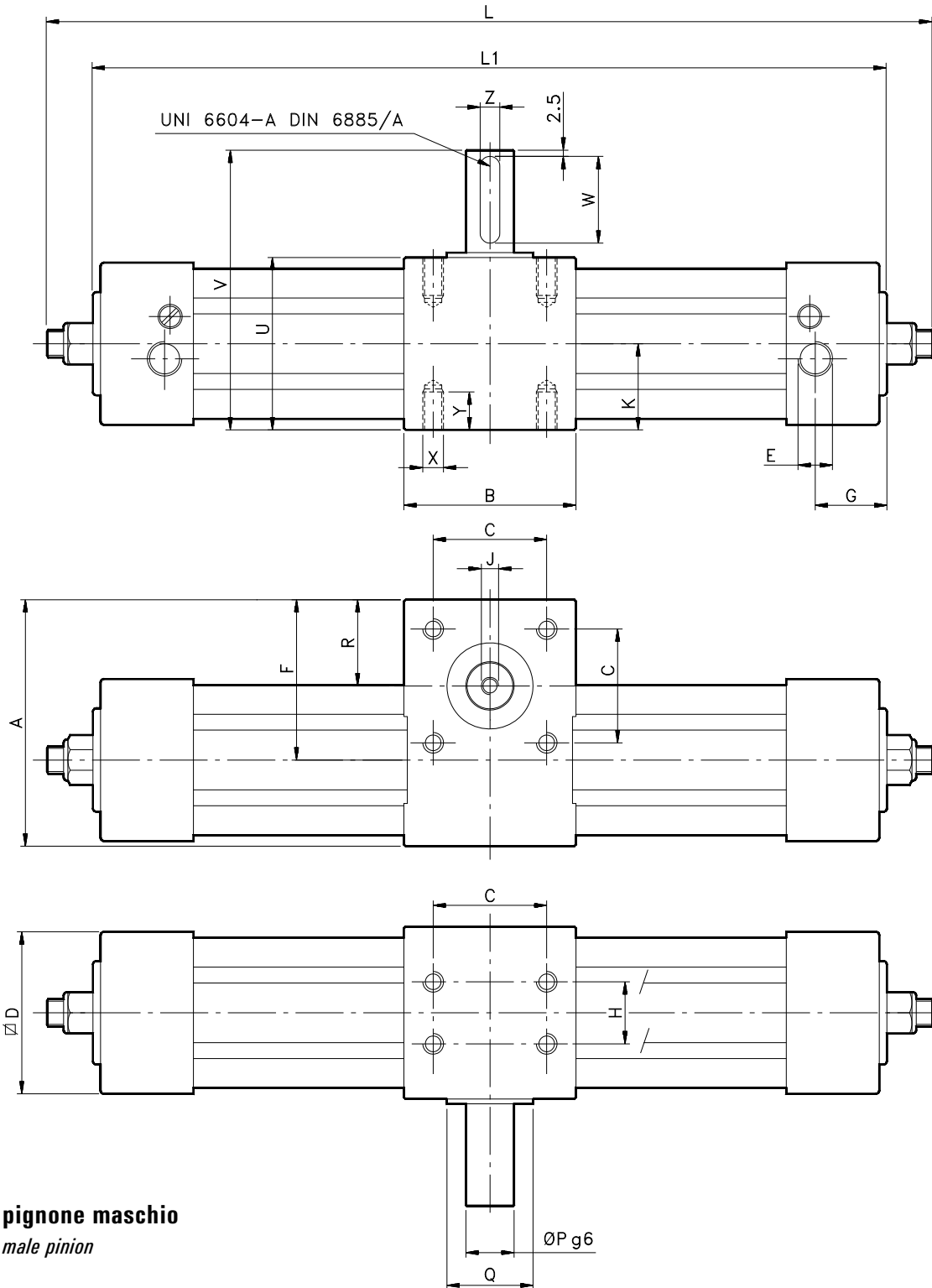

**pignone maschio**  
male pinion

rotazione 90° 90° rotation		
ø CIL.	L	L1
32	238	219
40	282	261
50	306	284
63	353	330
80	408	380
100	451	419
125	520	490
rotazione 180° 180° rotation		
ø CIL.	L	L1
32	285	266
40	339	318
50	369	347
63	428	405
80	507	479
100	558	526
125	652	622
rotazione 270° 270° rotation		
ø CIL.	L	L1
32	332	313
40	396	375
50	432	410
63	503	480
80	606	578
100	665	633
125	784	754
rotazione 360° 360° rotation		
ø CIL.	L	L1
32	379	360
40	453	432
50	495	473
63	578	555
80	705	677
100	772	740
125	916	886

ø CIL.	A	B	C	D	E	F	G	H	J	K	P	Q	R	U	V	W	X	Y	Z
32	71.5	50	33	48	G1/8"	46.5	18	18	M5	25	14	25	25	50	81	25	M6	10	5
40	82	60	40	54	G1/4"	54.5	21	22	M5	30	14	25	30	60	91	25	M6	10	5
50	93	70	50	67	G1/4"	60.5	24	25	M6	32.5	19	30	32.5	65	106	35	M8	13	6
63	109	75	60	78	G3/8"	70.8	26	35	M8	37.5	24	30	37	75	116	35	M8	13	8
80	142	99	80	97	G3/8"	93.5	26	50	M8	49.5	28	45	50	99	150	45	M10	16	8
100	156.5	115	80	115	G1/2"	99	30	60	M10	57.5	38	50	54	115	166	45	M10	16	10
125	188	125	90	140	G1/2"	118	32	70	M10	70	38	60	60	140	191	45	M12	20	10

# cilindri rotanti

rotary cylinders

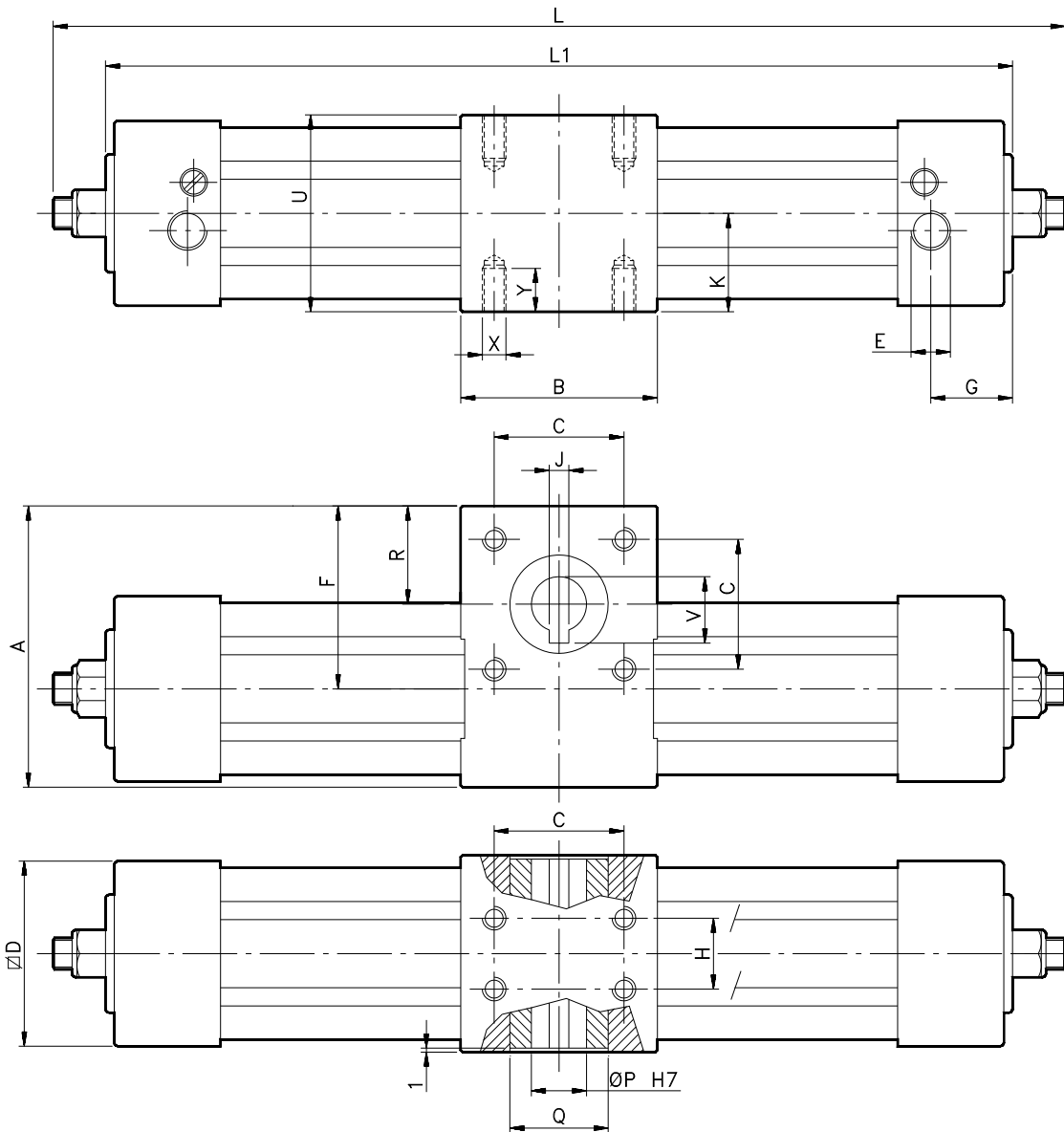

rotazione 90° 90° rotation		
ø CIL.	L	L1
32	238	219
40	282	261
50	306	284
63	353	330
80	408	380
100	451	419
125	520	490
rotazione 180° 180° rotation		
ø CIL.	L	L1
32	285	266
40	339	318
50	369	347
63	428	405
80	507	479
100	558	526
125	652	622
rotazione 270° 270° rotation		
ø CIL.	L	L1
32	332	313
40	396	375
50	432	410
63	503	480
80	606	578
100	665	633
125	784	754
rotazione 360° 360° rotation		
ø CIL.	L	L1
32	379	360
40	453	432
50	495	473
63	578	555
80	705	677
100	772	740
125	916	886

**pignone femmina**  
female pinion

ø CIL.	A	B	C	D	E	F	G	H	J	K	P	Q	R	U	V	X	Y
32	71.5	50	33	47	G1/8"	46.5	20	18	5	25	14	25	25	50	16.3	M6	10
40	82	60	40	53	G1/4"	54.5	19	22	5	30	14	25	30	60	16.3	M6	10
50	93	70	50	65	G1/4"	60.5	22	25	6	32.5	19	30	32.5	65	21.8	M8	13
63	109	75	60	76	G3/8"	70.8	24	35	6	37.5	19	30	37	75	21.8	M8	13
80	142	99	80	94	G3/8"	93.5	24	50	8	49.5	24	45	50	99	27.3	M10	16
100	156.5	115	80	112.5	G1/2"	99	22	60	8	57.5	28	50	54	115	31.3	M10	16
125	188	125	90	136.5	G1/2"	118	29	70	8	70	28	60	60	140	31.3	M12	20