

Sensor output interface terminal

KCD2-EL

- 1-channel terminal amplifier
- NAMUR sensor input
- DC 24 V supply voltage
- Standard interface for prevention of signal transmission errors
- Switching status indicator, yellow LED
- Lead breakage monitoring: The lead breakage monitoring can be disconnected by bridging terminals 1 and 3
- Short-circuit proof electronic output
- Low noise sensitivity
- Compact terminal housing
- Clips onto standard 35 mm rail to DIN EN 50 022
- Degree of protection IP20

Sensor output interface terminal with lead breakage monitoring



Dimensions

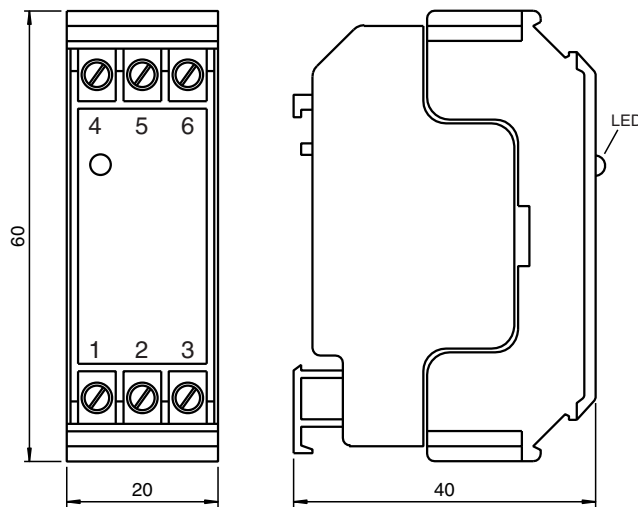

Technical Data

Functional safety related parameters

MTTF_d 1612 a

Indicators/operating means

LED yellow switch output
lead breakage: LED off, output locked

Electrical specifications

Operating voltage	U _B	10 ... 30 V DC
Ripple		≤ 10 %
Operating current	I _B	approx. 22 mA

Technical Data

Input	
Connection	terminals 1+, 2-
Connectable sensor types	NAMUR
Pulse length/pulse interval	$\geq 0.5 \text{ ms} / \geq 0.5 \text{ ms}$
Short-circuit current	approx. 8 mA
Sensor supply	8 V DC
Switching point	1.2 ... 2.1 mA hysteresis approx. 0.2 mA
Line fault detection	with
Trip value	1 kHz
Output	
Connection	terminal 4-
Current	200 mA short-circuit protected
Transistor	NPN
Signal level	$U_B - 1.8V$
Transfer characteristics	
Mode of operation	NO contact
Switching frequency	1 kHz
Directive conformity	
Electromagnetic compatibility	
Directive 2014/30/EU	EN 61326-1:2013
Standard conformity	
Degree of protection	EN 60529:2000
Noise immunity	EN 61326-1:2013
Ambient conditions	
Ambient temperature	-25 ... 70 °C (-13 ... 158 °F)
Storage temperature	-25 ... 85 °C (-13 ... 185 °F)
Mechanical specifications	
Degree of protection	IP20
Connection	self-opening apparatus connection terminals, max. core cross-section 0.34 ... 2.5 mm ²
Mass	60 g
Dimensions	20x60x40 (in mm)

Connection

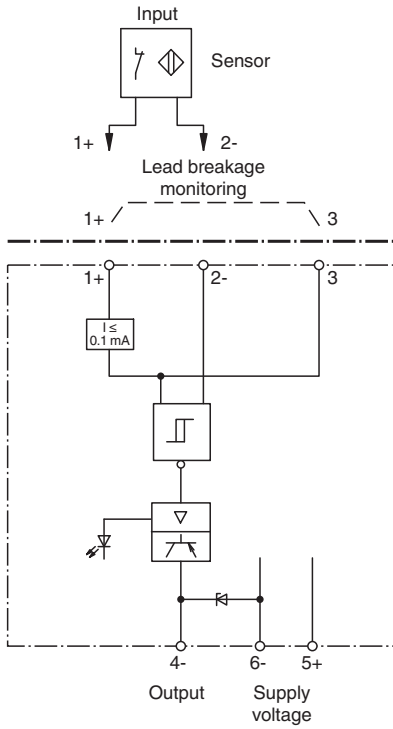

Release date: 2020-03-26 Date of issue: 2020-09-03 Filename: 018357_eng.pdf

Connection

For lead break monitoring you must switch a resistance of 10 kOhm parallel to the contact locally, if you use a mechanical contact as an emitter.