



Ultrasonic sensor

UB500-30GM65-WS3-BHMS5

- AC switchpoint output
- 330° high visibility LEDs
- Fingertip range adjustability

Single head system



Dimensions

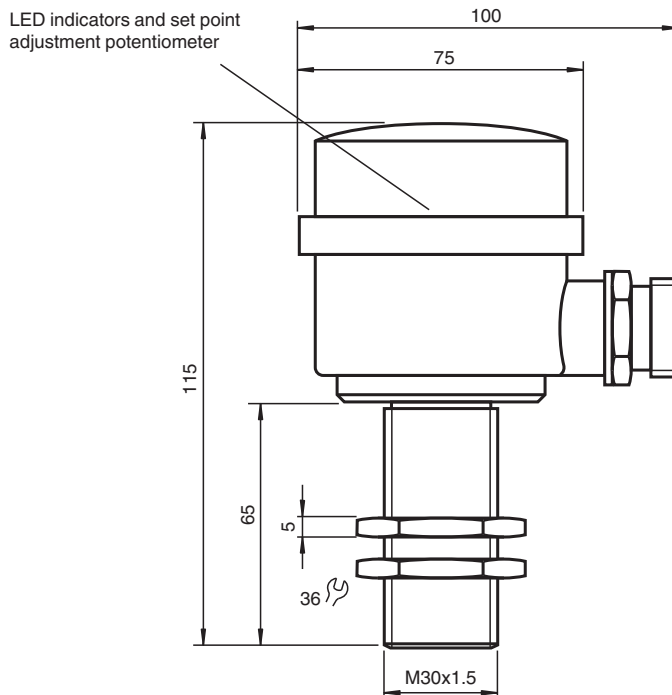

Technical Data

General specifications

Sensing range	70 ... 500 mm
Dead band	0 ... 70 mm
Standard target plate	100 mm x 100 mm
Transducer frequency	400 kHz
Response delay	≤ 45 ms

Indicators/operating means

LED green	power
LED red	Output

Electrical specifications

Release date: 2025-06-03 Date of issue: 2025-06-03 Filename: 093950_eng.pdf

Technical Data

Operating voltage	U_B	90 ... 140 V AC
Power consumption	P_0	≤ 75 mA
Output		
Output type		Thyristor , 1 NO
Rated operating current	I_e	700 mA
Voltage drop	U_d	≤ 1.5 V AC
Repeat accuracy		≤ 5 mm
Switching frequency	f	15 Hz
Range hysteresis	H	approx. 15 mm
Temperature influence		< 2 % of far switch point
Compliance with standards and directives		
Standard conformity		
Standards		EN IEC 60947-5-2:2020 IEC 60947-5-2:2019
Approvals and certificates		
UL approval		cULus Listed, General Purpose
Ambient conditions		
Ambient temperature		-25 ... 70 °C (-13 ... 158 °F)
Storage temperature		-40 ... 85 °C (-40 ... 185 °F)
Mechanical specifications		
Connection type		5-pin , V95 connector
Degree of protection		IP65
Material		
Housing		nickel plated brass; plastic components: PBT
Transducer		epoxy resin/hollow glass sphere mixture; polyurethane foam
Dimensions		
Diameter		30 mm

Connection Assignment

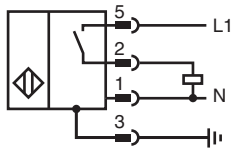

Connection Assignment

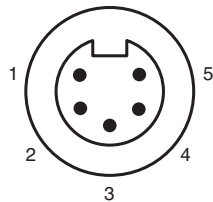

Release date: 2025-06-03 Date of issue: 2025-06-03 Filename: 093950_eng.pdf

Characteristic Curve

Characteristic response curve

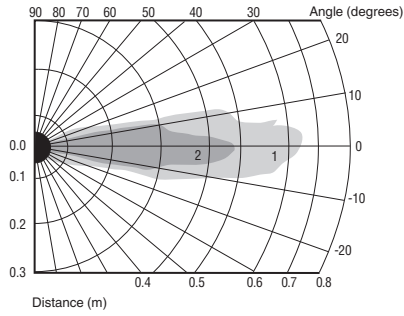

Curve 1: Flat surface 100 mm x 100 mm
Curve 2: Round bar, \varnothing 25 mm

Release date: 2025-06-03 Date of issue: 2025-06-03 Filename: 093950_eng.pdf

Configuration

Adjustment procedure

The UB500 provides an N.O. switch point output between 70 mm (non-adjustable) and the potentiometer configured end point (70 - 500 mm). The sensing window end limit is adjusted as follows:

Programming

1. Place the target at the desired distance
2. Turn the sensing potentiometer (on the back of the unit) counterclockwise until the red output LED turns off.
3. Slowly turn the potentiometer clockwise. The sensing range is set when the red output LED turns on.

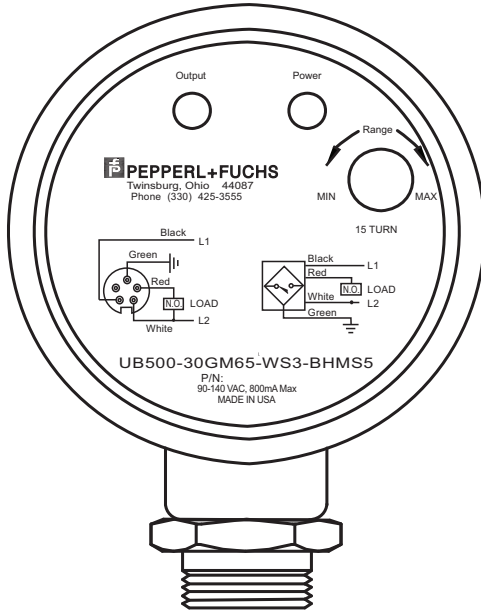

Installation Conditions

If the sensor is installed in an environment where the temperature can fall below 0 °C, one of these mounting flanges must be used for mounting: BF30, BF30-F, or BF 5-30.

If it is intended to operate the sensor at - 25 °C, we recommend discussing the mounting situation with a Pepperl + Fuchs application specialist to ensure a trouble-free operation.

If the sensor is mounted in a through hole using the included steel nuts, it must be mounted at the middle of the threaded housing. If it must be mounted at the front end of the threaded housing, plastic nuts with centering ring (optional accessories) must be used.

Release date: 2025-06-03 Date of issue: 2025-06-03 Filename: 093950_eng.pdf