



## Palm Button

### PB2-008-6

- Hand sensitive actuation
- Requires no physical pressure to initiate
- Reduces risk of repetitive motion injuries

Palm Button



## Dimensions

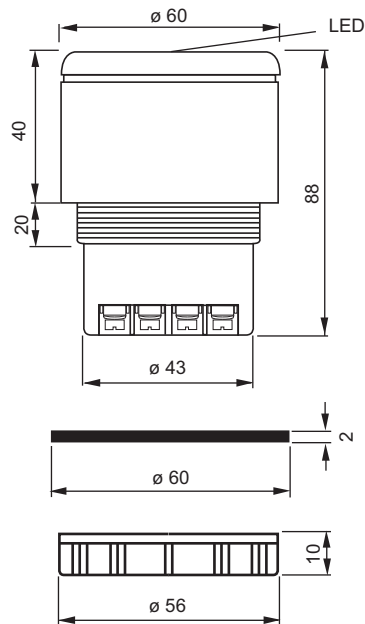

## Technical Data

### General specifications

Description hand sensitive actuation

### Nominal ratings

Operating voltage  $U_B$  24 V DC

Current consumption 100 mA

### Indicators/operating means

Switching state 1 LED

## Technical Data

### Output

Number/Type		2 NO; 2 NC
Output type		Contact set ; Relay output (contacts are one-way guided)
Switching voltage		max. 250 V AC
Switching current		1 A AC/DC ( resistive load and inductive load )
Switch-on delay	$t_{on}$	$\leq 60$ ms
Switch-off delay	$t_{off}$	$\leq 80$ ms
Mechanical life		$\geq 5 \times 10^7$
Electrical life		$\geq 5 \times 10^6$

### Electromagnetic compatibility

Electrostatic discharge		
Contact discharging		8 kV
Electromagnetic fields		
Radio frequency immunity IEC61000-4-3		10 V/m , see note 1
Burst IEC 61000-4-4		4 kV
Surge IEC 61000-4-5		symmetrical: 500 V asymmetrical: 500 V
Conducted noise immunity IEC 61000-4-6		10 V <sub>rms</sub> , see note 1

### Approvals and certificates

UL approval		UL 991
CSA approval		CSA C22.2, No. 14

### Ambient conditions

Ambient temperature		-18 ... 50 °C (0 ... 122 °F)
Shock resistance		45 g for 2 ms

### Mechanical specifications

Connection type		screw terminals
Degree of protection		IP64
Material		Palm Button : Noryl N190 Protective cover Noryl N190
Note		Palm Button

## Connection

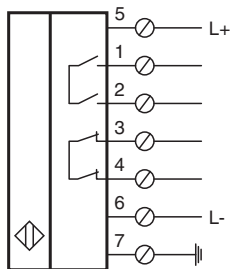

Release date: 2024-01-03 Date of issue: 2024-01-03 Filename: 094145\_eng.pdf

## Application



### Warning

This product may cause substantial personal injury or property damage if it is not installed and used in accordance with the manufacturer's instructions and in accordance with the regulations of the Occupational Safety and Health Administration part 1910.217, the procedures prescribed by the American National Standards Institute B11.1 and B11.19, and all other applicable regulations, procedures, and codes. The manufacturer shall not be responsible or liable for any injury or damage resulting from use of the product in any such applications or the failure to comply with any such regulation, procedure or code.

**NOTE 1:** If palm button face is not covered, its output relays will not be activated. If palm button face is covered, the sensor defaults to a safe state (output relays are deactivated). (Refers to RFI/EMI noise interference.)

## Safety Information



### IMPORTANT

Before installing, refer to ANSI B11.1, B11.19 and OSHA 1910.217.

Should the switch be used in a two-hand control application, each hand control shall be protected against unintended operation and arranged by design, construction, and/or separation so that the concurrent use of both hands is required to trip the press. The control system shall be designed to permit an adjustment which will require concurrent pressure from both hands during the die closing portion of the stroke. The control system shall incorporate an antirepeat feature. The control systems shall be designed to require release of all operator's hand controls before an interrupted stroke can be resumed.

Should the switch be used in a two-hand trip application, a two-hand trip shall have the individual operator's hand controls protected against unintentional operation and have the individual operator's hand controls arranged by design and construction and/or separation to require the use of both hands to trip the press and use a control arrangement requiring concurrent operation of the individual operator's hand controls. Two-hand trip systems on full revolution clutch machines shall incorporate an antirepeat feature.

Rings or shrouds are commonly used to protect palm-actuated buttons from unintentional actuation. Precautions in design or installation are needed to prevent actuation of two buttons by the use of one hand and the elbow of the same arm and to inhibit other circumvention of the two-hand requirement.

The device shall be located at a distance from the nearest hazard such that the operator cannot reach the hazard with a hand or other body part before cessation of motion of the hazardous portion of the machine cycle. Descriptions of formulas for distances, between the switches and from the nearest hazard, can be found in American National Standards Institute (ANSI) B11.1 and B11.19.

Since each two-hand control or trip application is different, the user needs to make sure that all Occupational Safety and Health Administration (OSHA) and American National Standards Institute (ANSI) requirements are followed.

This device shall be installed so that the distance between the terminal connections of the palm button switch and a dead metal part (including the enclosure) is a minimum of 1/4" (6.35 mm).