

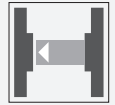

Thru-beam sensor

M12/MV12-F1/76b/82b/115/128



- Series of sensors in a widely used standard housing
- TEACH-IN switch for setting the contrast detection levels
- Automatic adjustment in case of soiling in contrast detection mode
- High level of stability thanks to the metal housing frame
- Resistant against noise: reliable operation under all conditions

Robust thru-beam sensor for standard applications, small design, 25 m detection range, red light, emission frequency F1, light/dark on, push-pull output, weak signal output, test input, external Teach-In, fixed cable



Dimensions

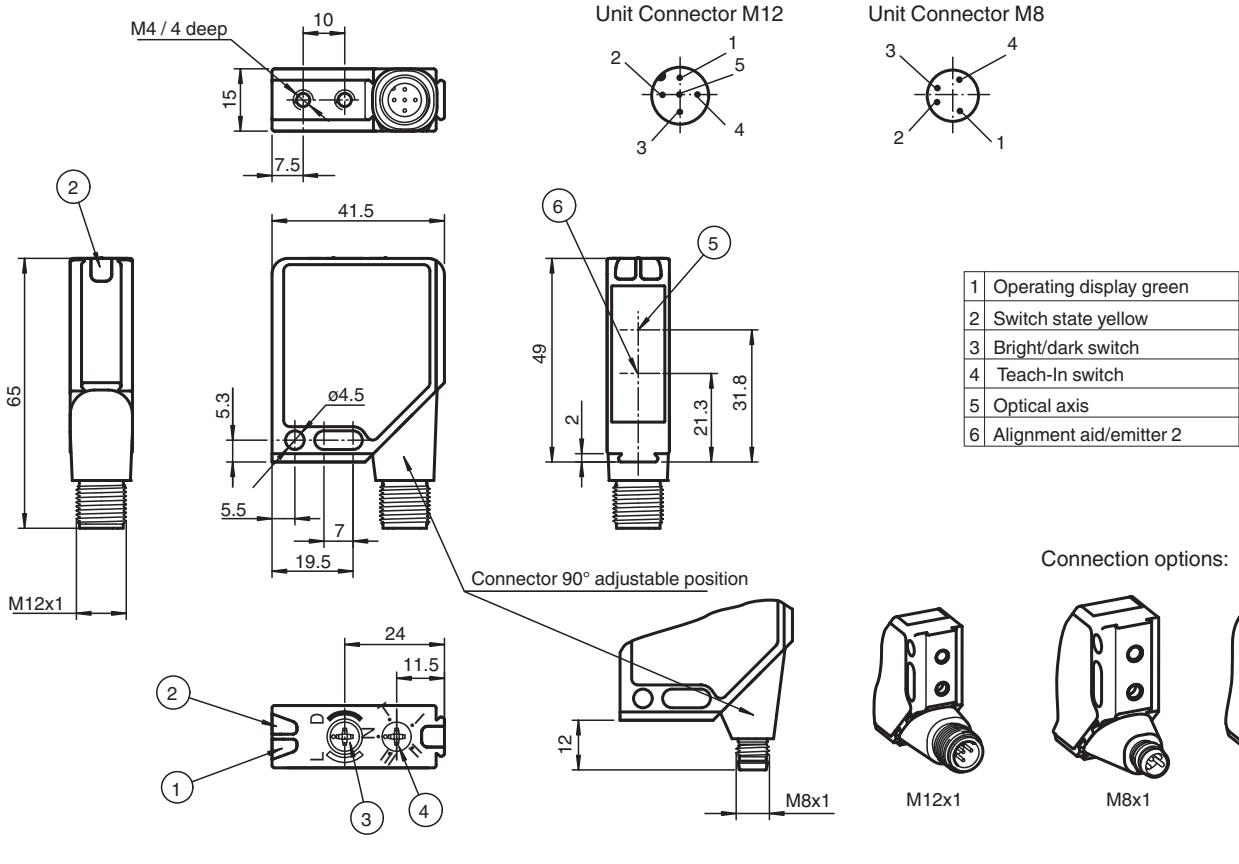

Release date: 2023-04-04 Date of issue: 2023-04-04 Filename: 115972_eng.pdf

Technical Data

System components		
Emitter		M12-F1/76b/115
Receiver		MV12-F1/82b/115/128
General specifications		
Effective detection range		0 ... 16 m
Threshold detection range		25 m
Light source		2 LED
Light type		modulated visible red light , 660 nm
Target size		min. 12 mm
Alignment aid		LED red in receiver
Diameter of the light spot		approx. 420 mm at a distance of 16 m
Opening angle		1.5 °
Ambient light limit		
Continuous light		40000 Lux
Modulated light		5000 Lux
Functional safety related parameters		
MTTF _d		570 a
Mission Time (T _M)		20 a
Diagnostic Coverage (DC)		90 %
Indicators/operating means		
Operation indicator		LED green, flashes in case of short-circuit
Function indicator		2 LEDs yellow for switching state, stability control, TEACH-IN and contrast detection mode
Control elements		rotary switch for light/dark, 5-step switch for contrast recognition adjustment
Contrast detection levels		15 % - clear glass bottles 25 % - plastic foils 40 % - colored glass or opaque materials adjustable by Teach-In key or external wire
Electrical specifications		
Operating voltage	U _B	10 ... 30 V DC
Ripple		max. 10 %
No-load supply current	I ₀	Emitter: ≤ 35 mA Receiver: ≤ 45 mA
Input		
Test input		emitter deactivation at 0 V
Function input		Ext. Teach-In input (ET)
Output		
Stability alarm output		1 PNP, inactive when level falls below function reserve after approx. 5 s. Immediately inactive if the beam is interrupted 4 times during the flashtime.
Switching type		light/dark on, switchable
Signal output		1 push-pull (4 in 1) output, short-circuit protected, reverse polarity protected
Switching voltage		max. 30 V DC
Switching current		max. 0.2 A
Voltage drop	U _d	≤ 2.5 V DC
Switching frequency	f	1000 Hz
Response time		0.5 ms
Conformity		
Product standard		EN 60947-5-2
Compliance with standards and directives		
Standard conformity		
Shock and impact resistance		IEC / EN 60068. half-sine, 40 g in each X, Y and Z directions
Vibration resistance		IEC / EN 60068-2-6. Sinus. 10 -150 Hz, 5 g in each X, Y and Z directions
Approvals and certificates		
Protection class		II, rated voltage ≤ 300 V AC with pollution degree 1-2 according to IEC 60664-1
UL approval		cULus

Technical Data

CCC approval	CCC approval / marking not required for products rated ≤36 V
Ambient conditions	
Ambient temperature	-40 ... 60 °C (-40 ... 140 °F)
Storage temperature	-40 ... 75 °C (-40 ... 167 °F)
Mechanical specifications	
Housing width	41.5 mm
Housing height	49 mm
Housing depth	15 mm
Degree of protection	IP67
Connection	2500 mm fixed cable , PUR
Material	
Housing	Frame: nickel plated, die cast zinc, Laterals: glass-fiber reinforced plastic PC
Optical face	Plastic pane
Mass	120 g (emitter and receiver)

Connection Assignment

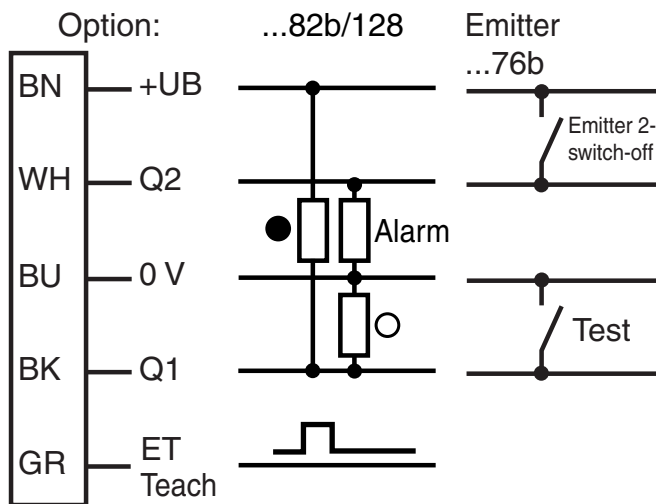

○ = Light on
● = Dark on

Characteristic Curve

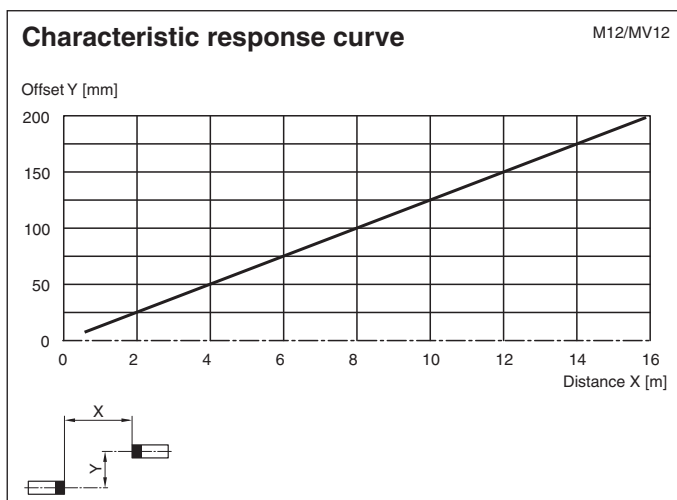

Release date: 2023-04-04 Date of issue: 2023-04-04 Filename: 115972_eng.pdf

Characteristic Curve

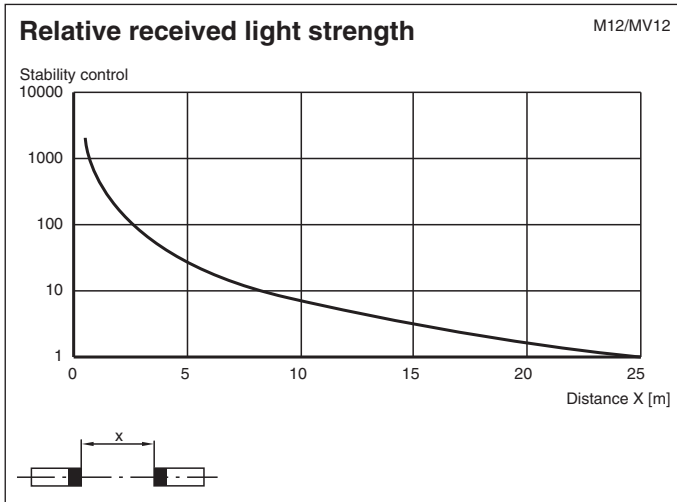

Mounting

Montage und Justage Montage et Alignement Montaggio e Aggiustaggio

In Schalterstellung "N" Sender und Empfänger ausrichten bis:
Gelbe LED leuchtet konstant,
rote LED ist aus.

In switching position "N" emitter and receiver align to:
Yellow LED lights up constantly,
red LED is off.

Dans le "N" les expéditeurs et destinataires de position de
commutation alignez :
Jaunissez la DEL s'allume constamment,
DEL rouge est dehors.

En los recipientes "N" de la posición de conmutación los
remitentes y alinean:
El LED amarillo se enciende para arriba constantemente,
LED rojo está hacia fuera.

Nel del "N" di posizione di commutazione i trasmettitori ed i
destinatari si allineano:
Il LED giallo si illumina costantemente in su,
LED rosso è fuori.

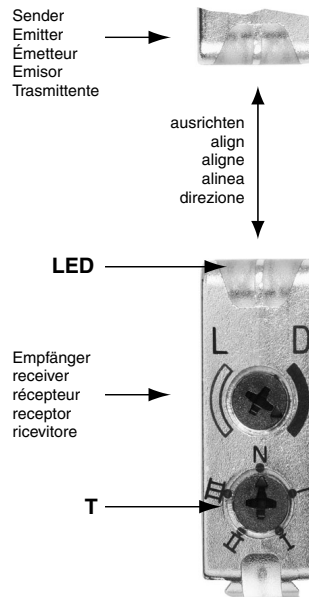

Mounting and Alignment Montaje y Ajuste



Accessories

	OMH-MLV12-HWG	Mounting bracket for series MLV12 sensors
	OMH-MLV12-HWK	Mounting bracket for series MLV12 sensors
	OMH-K01	dove tail mounting clamp
	OMH-K02	dove tail mounting clamp

Accessories

	OMH-K03	dove tail mounting clamp
	OMH-06	Mounting aid for round steel \varnothing 12 mm or sheet 1.5 mm ... 3 mm

Notes

Alignment

In switching position "N" senders and recipients align to:
Yellow LED lights up constantly, red LED is off.

TEACH-IN

Switch position "N" (standard operation):

LEDs are lit when the light beam is unobstructed, they flash when the value falls short of the function reserve and switch off when the beam is interrupted.

Switch position "T" (Teach-in mode):

After 1 s, the LED flashes slowly (approx. 1.5 Hz). The sensor is now ready to be set for a specific contrast detection value either via the mechanical switch (pos. I, II or III) or an external signal.

Switch positions "I", "II" and "III" (contrast detection mode)

Contrast recognition values: I for 15 %, II for 25 %, III for 40 %

1. LED permanently lit: light path unobstructed
2. LED off: element to be sensed detected
3. LED flashes rapidly: detection failure, excessive soiling, function reserve too low.

Ext. TEACH-IN input

The desired contrast recognition capability can be adjusted by applying of a logic „high“ pulse with a certain pulse length when the switch is in position T.

I: 50 ms (30 ms ... 100 ms)

II: 150 ms (100 ms ... 200 ms)

III: > 200 ms

Mode selector in position T.

