



Model number

VAA-4E4A-CB-ZE/E2-Y129640

Circuit board module
4 inputs/4 outputs

Features

- Integrated communication monitoring function
- Inputs and outputs short-circuit and overload proof
- Connection via Card-Edge plug connector (AMP 145432-2)
- Power supply of outputs from the external auxiliary voltage
- Inputs are galvanically separated from each other
- Detection of output overload
- Function display for bus, ext. auxiliary voltage, inputs and outputs
- Addressing jack

Dimensions

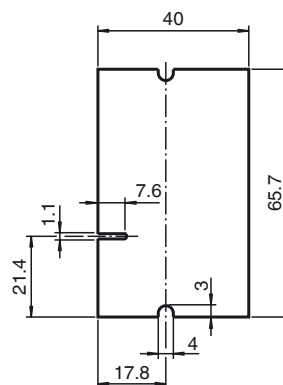

Electrical connection

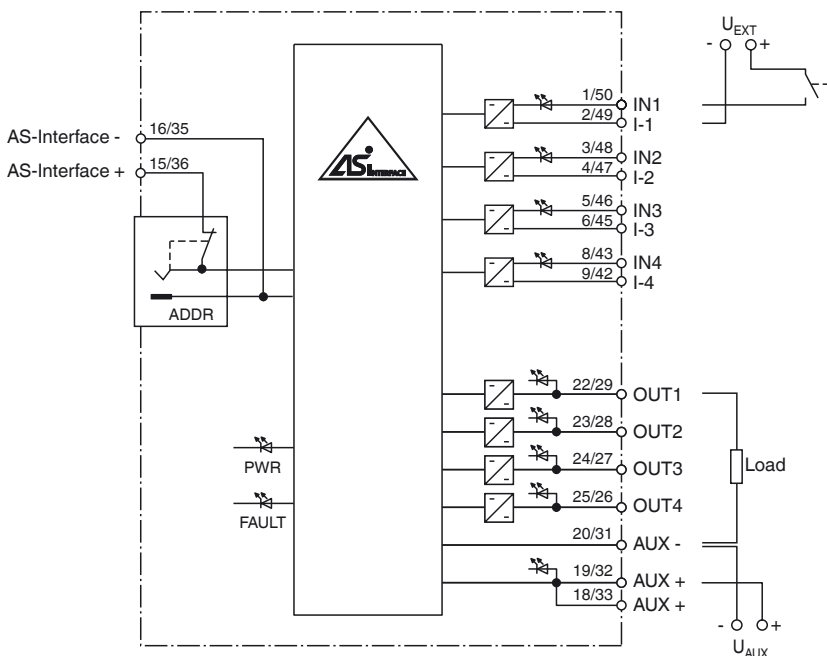

Indicating / Operating means

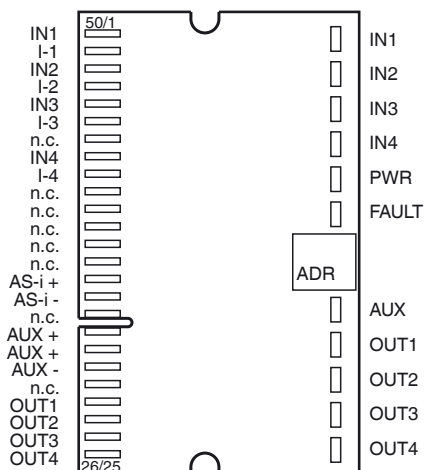

ase date: 2020-02-06 11:42 Date of issue: 2020-02-06 129640_eng.xml

General specifications

Slave type	Standard slave
AS-Interface specification	V2.1

Indicators/operating means

LED FAULT	error display; LED red red: communication error or address is 0 red flashing: overload of outputs
LED PWR	AS-Interface voltage; LED green
LED AUX	ext. auxiliary voltage U_{AUX} ; LED green
LED IN	switching state (input); 4 LED yellow
LED OUT	Switching state (output); 4 LED yellow

Electrical specifications

Auxiliary voltage (input)	U_{EXT}	20 ... 30 V DC PELV
Auxiliary voltage (output)	U_{AUX}	20 ... 30 V DC PELV
Rated operating voltage	U_e	26.5 ... 31.6 V from AS-Interface
Rated operating current	I_e	≤ 40 mA
Protection class		III

Input

Number/Type	4 inputs for 2- or 3-wire sensors (PNP), DC
Supply	from external auxiliary voltage U_{EXT}
Input current	≤ 8 mA (limited internally)
Switching point	according to EN 61131-2 Type 2
0 (unattenuated)	≤ 2 mA
1 (attenuated)	≥ 4 mA

Output

Number/Type	4 electronic outputs, PNP
Supply	from external auxiliary voltage U_{AUX}
Current	≤ 700 mA per output

Standard conformity

Degree of protection	EN 60529:2000
AS-Interface	EN 62026-2:2013

Programming instructions

Profile	S-7.0
IO code	7
ID code	0
ID1 code	F
ID2 code	E

Data bits (function via AS-Interface)	input	output
D0	IN1	OUT1
D1	IN2	OUT2
D2	IN3	OUT3
D3	IN4	OUT4

Parameter bits (programmable via AS-i) function

P0	not used
P1	not used
P2	not used
P3	not used

Ambient conditions

Ambient temperature	-25 ... 60 °C (-13 ... 140 °F)
Storage temperature	-25 ... 85 °C (-13 ... 185 °F)

Mechanical specifications

Connection	Card edge connector, type AMP 145432-2
Mass	approx. 13 g
Dimensions	65.7 mm x 40 mm x 8 mm

Notes**Function**

The AS-Interface printed circuit board module is intended for use in backplane applications that offer the possibility of highly flexible configuration with additional plug-in modules.

Mounting and contact are achieved by plugging into a plug-in slot on the backplane side (Card Edge Type AMP 145432-2). Mechanical coding protects the printed circuit board modules against being inserted incorrectly, thus reversing polarity. Mechanical locking in the connector prevents the printed circuit board module from accidentally coming loose after it has been plugged in.

Power must be supplied externally to the inputs and outputs connected to the module through an auxiliary power source. Power is supplied to the module itself from the AS-Interface circuit. This is indicated by an LED.

The inputs are galvanically separated from each other and from the outputs. The current switching state of each input and output is indicated by the corresponding IN and OUT LEDs.

The "periphery error" function as well as the FAULT LED will report an overloading of the outputs to the AS-Interface master. Communication over the AS-Interface remains in effect.

Note:

A communication monitoring system is integrated that deenergises the outputs if no communication is taking place on the AS-Interface line.