

WCS2 aluminum profile system

WCS2-GT09-P1

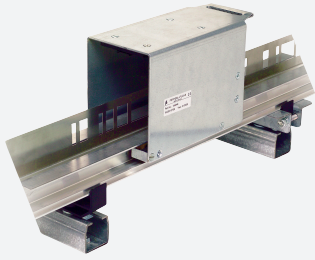

- Ensures the optimum alignment of reading head and code rail
- With prefitted mounting plate for reading head
- Cleaning brushes can be applied

WCS2 guiding trolley

Dimensions

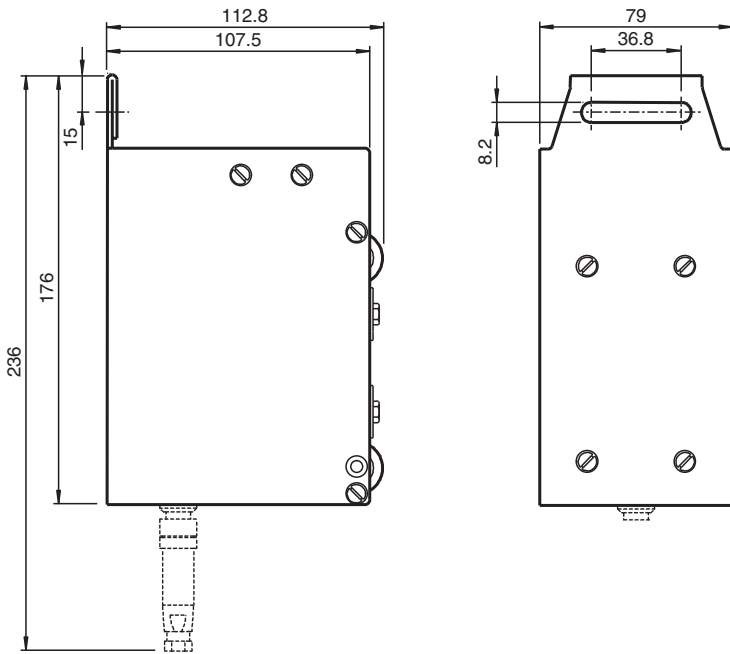

Technical Data

General specifications

Passage speed $v \leq 8 \text{ m/s}$

Ambient conditions

Operating temperature $-40 \dots 70 \text{ }^\circ\text{C}$ ($-40 \dots 158 \text{ }^\circ\text{F}$)

Mechanical specifications

Bending radius $\geq 1000 \text{ mm}$

Material Metal sheet (steel), zinc-plated
Plastic rollers

Mass 1000 g

Release date: 2025-03-17 Date of issue: 2025-03-17 Filename: 184046_eng.pdf