

## Dimensions

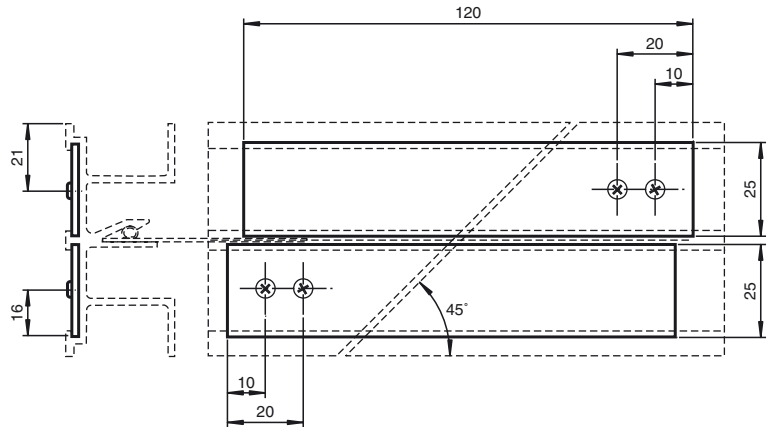

## Technical data

### Mechanical specifications

Material	Aluminum
Mass	100 g

### Notes

Connectors are necessary for joining the aluminium profile rails. Each connector (WCS-MC1) consists of two flat aluminium pieces and four self tapping screws (3 mm x 4.5 mm). The flat pieces are pushed into the bottom grooves in the two profile rails to be joined, with drillholes ahead. Then the screws are screwed into the holes of the flat pieces. The tips of the screws get pressed into the aluminium profile and fix the flat pieces in the grooves.

Stainless steel connectors (WCS-MC2) are used for joining of powder-coated aluminium profile rails.

### Model number

**WCS2-MC1**

Butt connector, aluminum

### Features

- Simple connection of profile rail segments

### Matching system components

**WCS3-PS1-O**

WCS3 profile rail

**WCS2-PS1**

WCS2 profile rail

**WCS2-PS1-8FT**

WCS2 profile rail

**WCS2-PS1-2,5M**

WCS2 profile rail