

WCS2 aluminum profile system

WCS2-GT09-M1

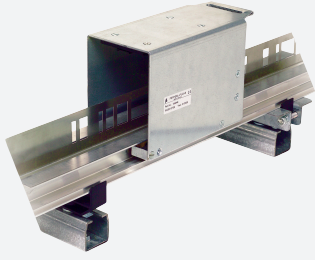

- Ensures the optimum alignment of reading head and code rail
- With prefitted mounting plate for reading head
- Cleaning brushes can be applied
- Metal rollers

WCS2 guiding trolley

Dimensions

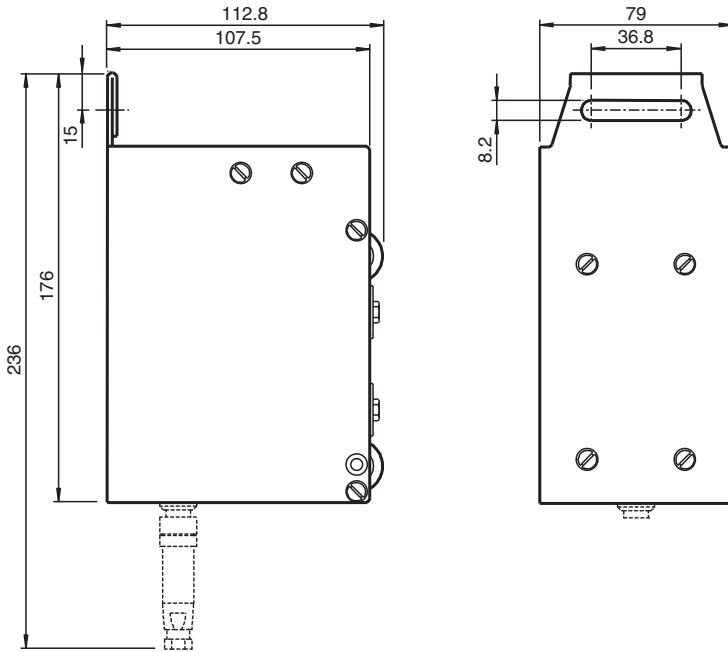

Technical Data

General specifications

Passage speed $v \leq 8$ m/s

Ambient conditions

Operating temperature $-40 \dots 70$ °C ($-40 \dots 158$ °F)

Mechanical specifications

Bending radius ≥ 1000 mm

Material Metal sheet (steel), zinc-plated
metal rollers

Mass 1000 g

Release date: 2025-03-17 Date of issue: 2025-03-17 Filename: 184480_eng.pdf