

Double plate sensor

UDCM-30GM-085-3E3



- Ultrasonic system for reliable detection of no, one, or two overlapping sheet materials, preferably sheet metal
- No teach-in required
- Insensitive to printing, colors, and shining surfaces
- Programmable



Dimensions

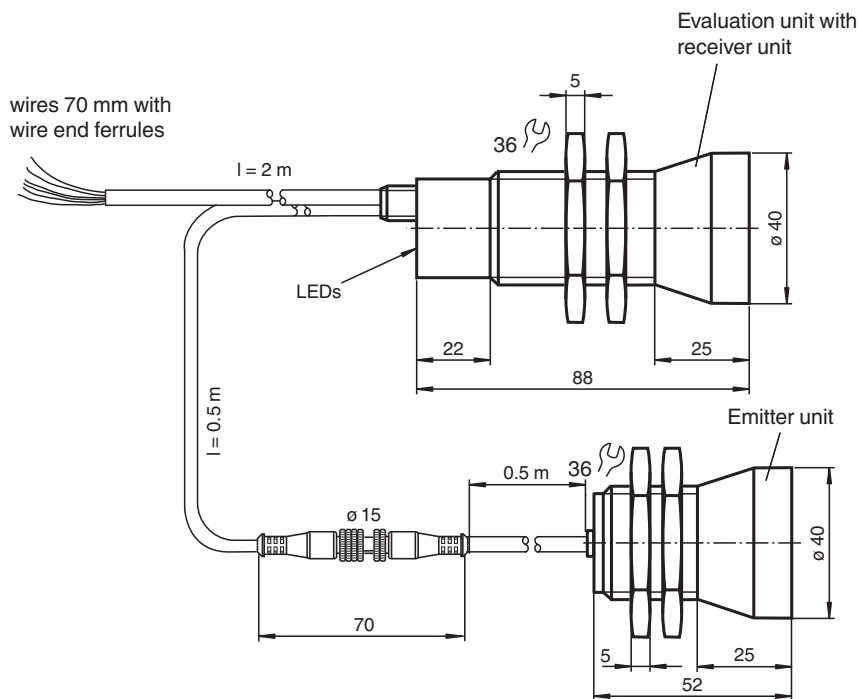

Technical Data

General specifications

Sensing range	50 ... 150 mm , optimal distance: 80 mm
Transducer frequency	85 kHz

Indicators/operating means

LED green	indication: single sheet metal detected
LED yellow	Indication: No sheet metal detected (Air)
LED red	indication: double sheet metal detected

Electrical specifications

Operating voltage	U_B	18 ... 30 V DC , ripple 10 % _{SS}
No-load supply current	I_0	< 200 mA

Release date: 2025-06-16 Date of issue: 2025-06-18 Filename: 193142_eng.pdf

Technical Data

Time delay before availability	t_v	< 500 ms
Input		
Input type		Function input 0-level: $-U_B \dots -U_B + 1V$ 1-level: $+U_B - 1V \dots +U_B$
Pulse length		≥ 100 ms
Function		in normal operation mode, the function input has to be connected with UB+ or UB-
Impedance		≥ 4 k Ω
Output		
Output type		3 switch outputs PNP, NC
Rated operating current	I_e	3 x 100 mA , short-circuit/overload protected
Voltage drop	U_d	≤ 3 V
Switch-on delay	t_{on}	approx. 30 ms
Switch-off delay	t_{off}	approx. 30 ms
Pulse extension		min. 120 ms programmable
Compliance with standards and directives		
Standard conformity		
Standards		EN IEC 60947-5-2:2020 IEC 60947-5-2:2019
Approvals and certificates		
UL approval		cULus Listed, General Purpose, Class 2 Power Source
CCC approval		CCC approval / marking not required for products rated ≤ 36 V
Ambient conditions		
Ambient temperature		0 ... 50 °C (32 ... 122 °F)
Storage temperature		-40 ... 70 °C (-40 ... 158 °F)
Mechanical specifications		
Connection type		cable PVC , 2 m
Core cross section		0.14 mm ²
Degree of protection		IP65
Material		
Housing		nickel plated brass; plastic components: PBT
Transducer		epoxy resin/hollow glass sphere mixture; polyurethane foam
Mass		300 g
Dimensions		
Length		90 mm
Diameter		40 mm
General information		
Supplementary information		Switch settings of the external programming adapter: "output load": pull-down "output logic": inv

Connection Assignment

Standard symbol/Connection:

Double sheet metal control

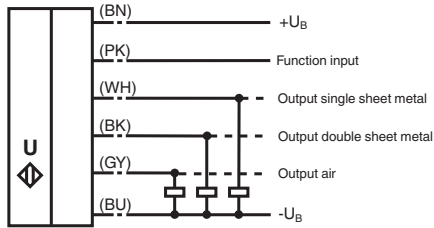

Mounting/Adjustment

Recommended distances

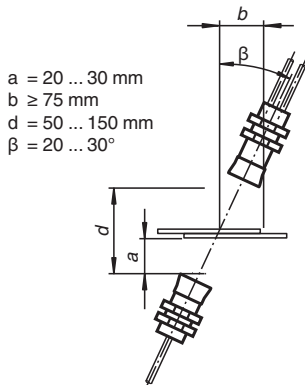

Angular misalignment

$\alpha < +/- 1^\circ$

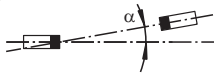

Sensor offset

$s < +/- 1 \text{ mm}$

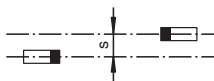

Additional Information

Description of sensor functions

The ultrasonic double-sheet monitor is deployed in all situations in which the automatic distinction between single and double sheets is required in order to protect machines or avoid waste production. The double-sheet monitor is based on the ultrasonic through-beam principle. The following can be detected:

- no sheet, i.e. air,
- single sheets
- double sheets or multiple sheets

A microprocessor system evaluates the signals. The appropriate switch outputs are set as a result of the evaluation. Changes in ambient conditions such as temperature and humidity are compensated for automatically. The evaluation electronics are integrated into an evaluation unit together with a sensor head in a compact M30 metal housing.

Electrical connection

The sensor is equipped with 6 connections. The functionality of the connections is described in the following table. The function input (PK) is used to assign parameters to the sensor. (see Output pulse extension, Alignment aid and Program selection). During normal operation, the function input must always be securely connected with +U_B or -U_B to avoid possible interference or improper functionality.

Color	Switching on	Comments
BN	+U _B	
WH	Switch output for single sheets	Pulse width corresponds to the event
BK	Switch output for double sheets	Pulse width corresponds to the event
GY	Switch output for air	Pulse width corresponds to the event
PK	-U _B +U _B	Function input for parameter assignment/pulse prolongation
BU	-UB	

Normal mode

The sensor is working in normal mode if the function input (PK) is applied to -U_B or +U_B when the power source (Power-On) is supplied, as shown in the output pulse extension table (see below).

Displays:

- LED yellow: Detection of air
- LED green: Detection of single sheets
- LED red: Detection of double sheets

Switch outputs:

The switch outputs are only active in normal mode!

- White: WH Single sheet output
- Black: BK Double sheet output
- Gray: GY Air output

Output pulse extension

Switching the function input (PK) on to -U_B or +U_B makes it possible to select a minimum pulse width of 120 ms for all output pulses of the three switch outputs.

Switching on (PK)	Operating behavior (after Power-On)
-U _B	No output pulse extension for switch outputs
+U _B	Output pulse extension of all switch outputs to at least 120 ms

Please note:

This can result in a condition in which more than one switch output is switched through!

Display mode

The selected parameter assignment of the sensor can be displayed by switching the function input (PK) to voltage-free during normal operation. The green LED displays the program number (the number of flashing pulses (1..4) = the program number). The outputs are inactive during this time.

If the function input (PK) is switched to voltage-free when power is supplied (Power-On), the sensor will also work in display mode.

If the function input (PK) is switched to voltage-free during operation due to an error (broken cable, coming loose because of vibration), the display mode acts as a fault display.

Parameter assignment

The sensor is equipped with 4 programs for different ranges of application. This makes it possible to work with a wide range of materials. The user can select the program best suited for a specific application.

The default setting, Program 1, is designed so that no change in the setting is required for most applications.

Release date: 2025-06-16 Date of issue: 2025-06-18 Filename: 193142_eng.pdf

Programs

Program number	Notes*
1	Default setting. Covers a wide spectrum of materials
2	Thick, heavy sheets
3	Thin sheets
4	Thin fine sheet metal, metal foils

The specified intended uses of program 1 ... 4 show orientation values for the user. In specific individual cases, the appropriate program to be selected for the respective material used must be empirically determined. The starting point here should be standard program 1.

Procedure for assigning parameters

It is possible to switch to additional parameter assignment modes from the display mode:

- Alignment mode -->
- Program selection mode -->
- Alignment aid mode --> (for checking)

When the function input (PK) is applied to $-U_B$ (for > 500 ms), the mode changes. When the "Program selection" mode is active, switching on function input (PK) to $+U_B$ (for > 500 ms) selects the next program level.

Disconnecting the power supply causes the system to exit the current mode with the selected program change.

The switch outputs are not active while parameters are being assigned to the sensor!

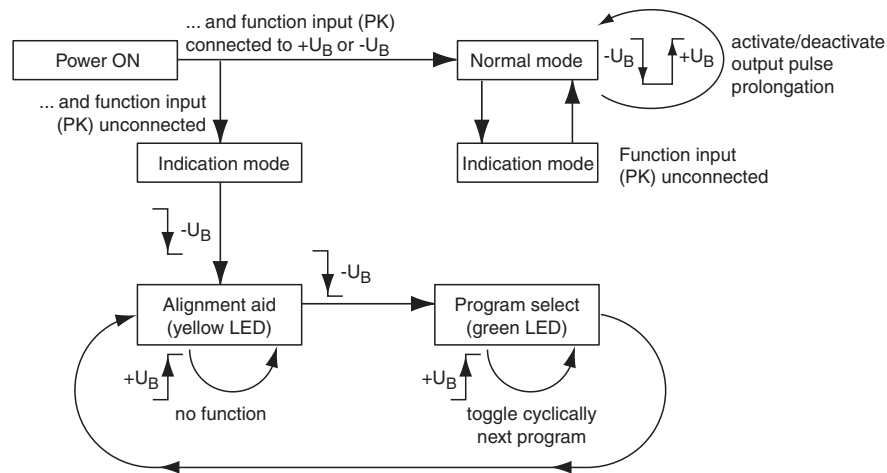

Modes

Amplitude control

During installation, the amplitude control can be used to check whether the ultrasonic amplitude at the receiver is sufficient. If the transmitter is not aligned properly in relation to the receiver, maximum sound energy is not transmitted to the receiver, which may result in the incorrect detection of materials.

When the sensor detects an area of air (yellow LED lights up), the UDC begins to display the strength of the measured amplitude signal:

- if the signal is weak, the yellow LED flashes at low frequency
- the flashing frequency increases in line with the signal strength
- the yellow LED lights up continuously when the signal strength is sufficient.

The single sheet function (green LED) and double sheet function (red LED) are now active. This can be used to check the correct function of the sensor.

Program selection

In the program selection mode, the current program is displayed by the green LED (number of flashing pulses = program number). Applying the adjustment input (PK) to $+U_B$ (for > 500 ms) causes the next program to be selected in cyclic sequence (program 1 follows through to program 4).

Notes:

A complete device consists of an ultrasonic emitter and an evaluation unit with an ultrasonic receiver. The sensor heads are optimally adjusted to each other when they leave the factory. Therefore, they must not be used separately or exchanged with other devices of the same type. The plug connector on the emitter/receiver connection cable is only intended to be used for easier mounting, not to replace units.

During installation, ensure that the ultrasonic signal cannot bypass the material being detected through multiple reflections. This can happen if, for example, large surfaces for sound reflection exist transverse to the direction of sound transmission. This can be caused by the use of unsuitable holding devices or large-surface system components. In the case of reflective system components, they must be covered with sound-absorbing material or a different installation site must be chosen.

Release date: 2025-06-16 Date of issue: 2025-06-18 Filename: 193142_eng.pdf

To ensure problem-free detection of double sheets, an air gap is required between the sheets. This prerequisite might not be met in cases where two sheets adhere to each other by means of an oil film, thus resulting in the detection of a single sheet only. If two or more UDCM double sheet controls are used in the immediate vicinity of each other, there may be mutual interference between them, which can result in improper functionality of the devices. Mutual interference can be prevented by introducing suitable countermeasures when planning systems.

Parameterization

Parameterization using *PACTware* ^{DTM}

The double sheet sensor can be connected using a V15S-G-0.3M-PUR-WAGO terminal adapter.



Connect the sensor to the terminal adapter according to the table below.

Terminal adapter wire color	Sensor cable wire color
Brown	Brown
Blue	Blue
Black	Black
Gray	Pink

The sensor features a time lock. If no communication request occurs, the time lock blocks parameterization of the sensor 30 seconds after the supply voltage is connected. Start *PACTware* before switching on the sensor so that the communication request can be made in time.