

# RFID Transponder

## IQC21-50F-T10



- Operating frequency 13.56 MHz
- With extended temperature range up to 220 °C (428 °F)
- Conforms to ISO 15693
- 896 bits memory available
- Readable and writable from both sides
- Degree of protection IP68
- Mounting holes for simple installation

Data carrier



### Application

The transponder can be read and written from either side.

### Dimensions

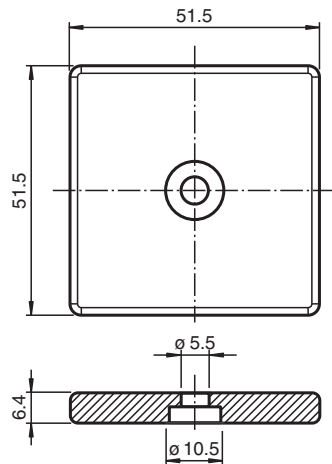

### Technical Data

#### General specifications

Operating frequency	13.56 MHz
Transfer rate	26 kBit/s

#### Memory

Chip Type	I-CODE SLI (NXP)
EEPROM	896 Bit
UID	64 Bit
Memory organization	4 bytes/block
Read cycles	unlimited
Write cycles	> 100000
Data retention period	10 years at 55 °C (131 °F)

#### Directive conformity

Radio equipment	
Directive 2014/53/EU	EN 300330

Release date: 2022-12-15 Date of issue: 2022-12-15 Filename: 197962\_eng.pdf

## Technical Data

RoHS	
Directive 2011/65/EU (RoHS)	IEC/EN 63000
<b>Standard conformity</b>	
Degree of protection	EN 60529
RFID	ISO/IEC 15693-1 ISO/IEC 15693-2 ISO/IEC 15693-3 ISO/IEC 18000-3
<b>Ambient conditions</b>	
Ambient temperature	-40 ... 85 °C (-40 ... 185 °F)
Storage temperature	-40 ... 220 °C (-40 ... 428 °F) 220 °C (493 K) for 1000 hours or 1500 cycles of 30 min
Climatic conditions	100 % non-condensing
<b>Mechanical specifications</b>	
Housing length	51.5 mm
Housing width	51.5 mm
Housing height	6.4 mm
Degree of protection	IP68
Material	
Housing	PPS
Installation	
In air	yes
Mass	25 g
Construction type	Rectangular type

## Mounting

High temperatures will cause the housing to expand.  
If the housing is assembled under mechanical stress, the resulting pressure may damage the tag.  
Install the tag loosely to allow for expansion due to high temperatures.

## Characteristic Curve

Reading range in air IQC21-50F-T10

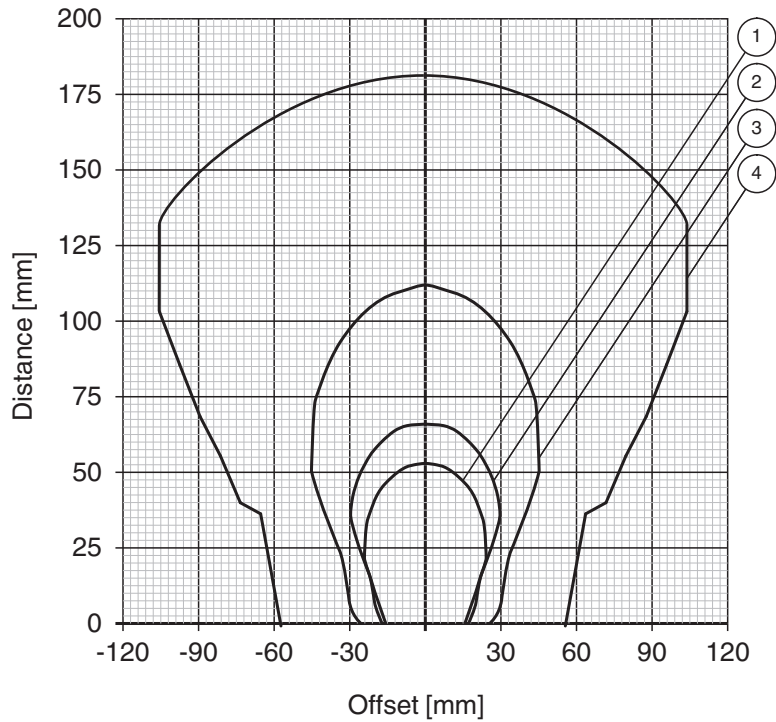

- ① IQH1-18GM-V1    ② IQH1-F61-V1    ③ IQH1-FP-V1  
 ④ IQH1-F15-V1

## Accessories

	<b>ICZ-MH30-25-T10</b>	Spacers for code/data carrier
---	------------------------	-------------------------------