



Photoelectric slot sensor

GL80-IR/32/40a/98a



- Optimized for the detection of small parts
- High switching frequency
- Multiple device installation possible, no mutual interference (no cross-talk)
- Sensitivity adjuster and light-on/dark-on changeover switch as standard features of this series
- Infrared light
- Degree of protection IP67
- cULus approval
- Diecast zinc housing, powder coated

Photoelectric slot sensor, zinc pressure diecast housing, 80 mm slot width, infrared light, light/dark on, sensitivity adjuster, DC version, PNP output, 3 pin M8 plug



Function

Photoelectric slot sensors offer vast installation benefits thanks to their housing design. When it comes to operation, these new generation devices boast features such as high resolution, high repeatability, automatic signal threshold adjustment, ambient light resistance, and detection of and/or light transmission through transparent objects. Cross-talk protection enables parallel installation of devices despite extremely high switching frequency. These characteristics guarantee reliable detection of small parts, from 0.3 mm, across the entire detection range, even in very fast moving applications.

Dimensions

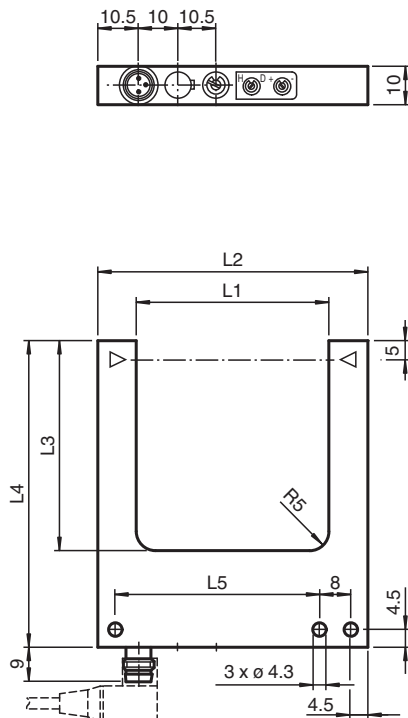

	L1	L2	L3	L4	L5
GL30..	30	50	35	60	33
GL50..	50	70	55	80	53
GL80..	80	100	55	80	83

Technical Data

General specifications

Light source	IRED
Light type	modulated infrared light
Tests	EN 60947-5-2

Release date: 2024-06-24 Date of issue: 2024-06-24 Filename: 198054_eng.pdf

Technical Data

Target size		0.3 mm
Slot width		80 mm
Slot depth		55 mm
Ambient light limit		100000 Lux
Functional safety related parameters		
MTTF _d		1290 a
Mission Time (T _M)		20 a
Diagnostic Coverage (DC)		0 %
Indicators/operating means		
Function indicator		LED red in connector
Control elements		Sensitivity adjuster, light/dark switch
Electrical specifications		
Operating voltage	U _B	10 ... 30 V DC, class 2
Ripple		10 %
No-load supply current	I ₀	≤ 15 mA
Output		
Switching type		light/dark on
Signal output		1 PNP, short-circuit protected, open collector
Switching voltage		max. 30 V DC
Switching current		max. 100 mA
Repeat accuracy		0.05 mm
Switching frequency	f	2 kHz
Response time		≤ 250 μs
Conformity		
Product standard		EN 60947-5-2
Approvals and certificates		
CE conformity		CE
UL approval		cULus
CCC approval		CCC approval / marking not required for products rated ≤36 V
Ambient conditions		
Ambient temperature		-20 ... 60 °C (-4 ... 140 °F)
Storage temperature		-20 ... 75 °C (-4 ... 167 °F)
Mechanical specifications		
Degree of protection		IP67
Connection		M8 connector, 3-pin
Material		
Housing		powder coated diecast zinc
Optical face		glass
Mass		125 g
Dimensions		
Height		100 mm
Width		10 mm
Length		80 mm

Connection Assignment

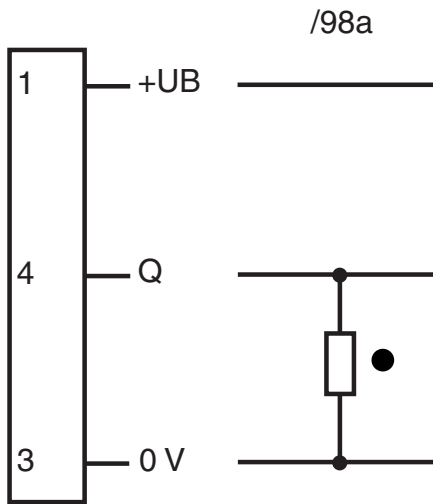

○ = Light on
● = Dark on

Connection Assignment



Wire colors in accordance with EN 60947-5-2

- 1 | BN (brown)
- 3 | BU (blue)
- 4 | BK (black)

Assembly

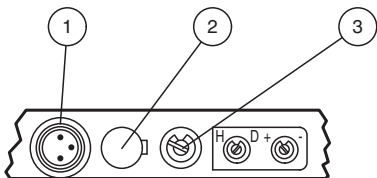

1	Functional display	red
2	Light-/dark switch	
3	Sensitivity adjuster	

Release date: 2024-06-24 Date of issue: 2024-06-24 Filename: 198054_eng.pdf

Application

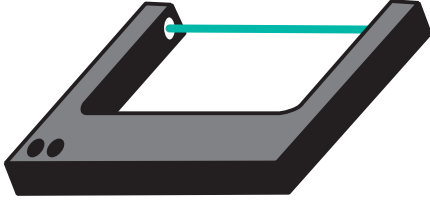

Function Principle

Photoelectric slot sensors are photoelectric sensors that operate according to the thru-beam sensor principle. The transmitter sends signals directly to the receiver. If an object breaks the light beam, the switching element function is triggered. The special U-shaped design means the transmitter and receiver can be accommodated in one housing, which ensures high resistance to vibrations. In contrast to standard thru-beam sensors, photoelectric slot sensors have the added advantage of not requiring complex electrical installation, as only one device needs to be connected. Also, adjustment of the optical axes is not necessary.

Application

- Small part detection, from object size 0.3 mm
- Can also be used for systems with strong vibrations
- Detection of small needles in transparent hollow needles
- Counting of small parts on conveyors
- Feed and correct separation verification
- Web edge control
- Elevator car position in elevators