



## WIS module secondary NDS-F146-8E2-V1

- 8 channels
- 8 sensor inputs
- Fast, flexible installation/separation

Inductive transmitter system



### Dimensions

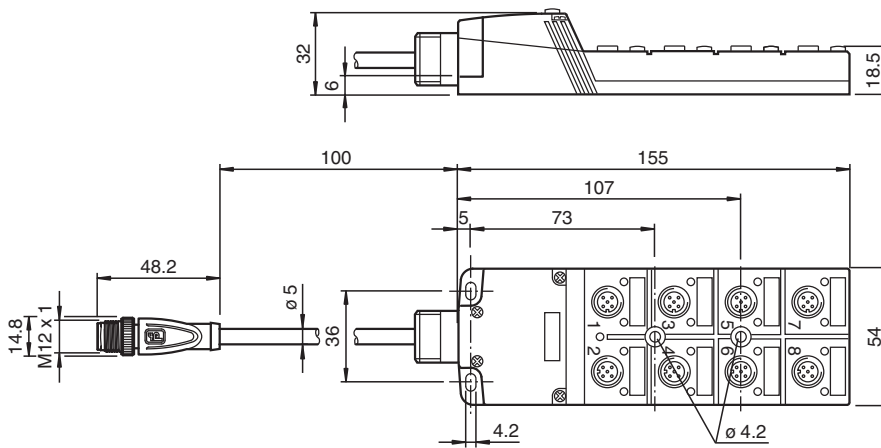

### Technical Data

| Nominal ratings                      |  |
|--------------------------------------|--|
| Number of signal channels            | 8  |
| Signal transfer direction            | from secondary side to primary side                |
| Sensor supply voltage                | 12 V ± 10 % , overload and short-circuit resistant |
| Ripple                               | ≤ 5 %  |
| Transfer power                       | max. 2.5 W (1.5 W at 5 mm)                         |
| Load step                            | ≤ 100 mA   |
| Functional safety related parameters |  |
| MTTF <sub>d</sub>                    | 465 a  |
| Mission Time (T <sub>M</sub> )       | 20 a   |
| Diagnostic Coverage (DC)             | 0 %  |
| Input                                |  |
| Number                               | 8  |
| Input type                           | Input for sensor signals                           |
| Connectable sensor types             | DC, 3-wire , PNP ( switched high )                 |
| Input current                        | ≤ 1 mA   |
| Internal resistor                    | ≥ 15 kΩ  |

Release date: 2024-05-28 Date of issue: 2024-06-06 Filename: 200663\_eng.pdf

## Technical Data

| Compliance with standards and directives |  |  |
|--|--|--|
| Directive conformity                     |  |  |
| EMC Directive 89/336/EEC                 |  | EN 61000-6-2:2001, EN 61000-6-4:2001, EN 50295:1999                              |
| Standard conformity                      |  |  |
| Standards                                |  | EN IEC 60947-5-2   |
| Approvals and certificates               |  |  |
| CCC approval                             |  | CCC approval / marking not required for products rated ≤36 V                     |
| Ambient conditions                       |  |  |
| Ambient temperature                      |  | 0 ... 50 °C (32 ... 122 °F)  |
| Storage temperature                      |  | -25 ... 85 °C (-13 ... 185 °F)   |
| Mechanical specifications                |  |  |
| Degree of protection                     |  | IP65   |
| Material                                 |  |  |
| Housing                                  |  | PA 66-FR   |
| Installation                             |  | screw mounting   |
| Mass                                     |  | 140 g  |
| General information                      |  |  |
| Note                                     |  | Maximum cable length between WIS module and WIS transmitter must not exceed 5 m. |

## Connection

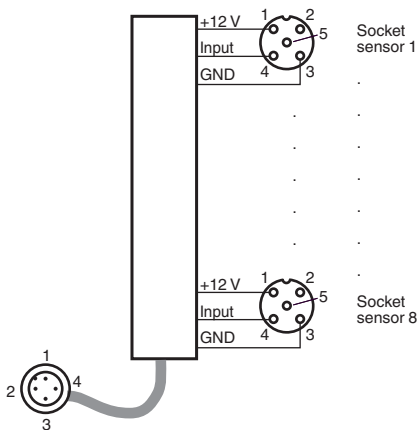

**Function**

**Functional description**

A WIS (wireless inductive system) inductive transfer system always consists of the following four components:

- WIS primary module
- WIS primary transmitter
- WIS secondary transmitter
- WIS secondary module

The WIS primary module is installed in the stationary component and is connected to a downstream control (i.e., PLC). The WIS primary transmitter connected to the WIS primary module. The WIS secondary transmitter and the WIS secondary module that is connected to it are installed in the moveable part of the component. The WIS secondary module disposes of connection capabilities for several sensors. If the two transmitters are located in front of each other within the system range, then electric power is transferred from the primary side to the secondary side. The sensors attached to the WIS secondary module are now supplied with electric energy and begin to operate. The sensor output signals are transmitted in the opposite direction from the secondary side to the primary side and are separately available on the WIS primary module output terminals for further processing by the equipment control. The sensor signal status is also displayed by LEDs that correspond to the sensor channels. A separate output signal Tx on the WIS primary module indicates the communication status. A high signal indicates communication between the WIS transmitters. This is also indicated by a glowing LED Tx.

Power transfer and communication in the system can be activated and deactivated on the WIS primary module with the EN input .

|                    |                      |
|--------------------|----------------------|
| Input signal on EN | Function             |
| + UB (24 V DC)     | Transfer activated   |
| GND or open.       | Transfer deactivated |

**Function schematic**

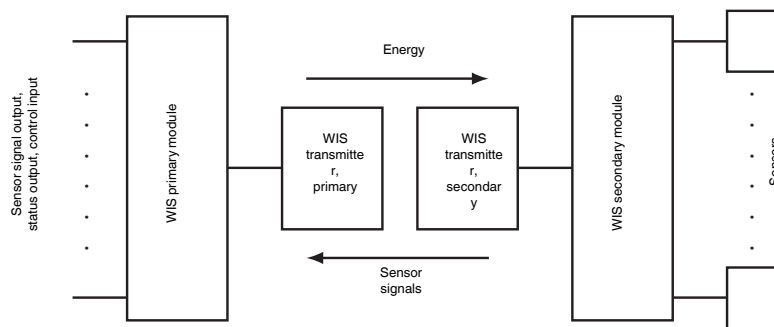

The sum of the currents of all sensors attached to the WIS secondary module must not be greater than the maximum transferable current. This is calculated by dividing the transferable power by the 12 V provided by the transmitters.

Release date: 2024-05-28 Date of issue: 2024-06-06 Filename: 200663\_eng.pdf