



Switch Amplifier

KFU8-SR-Ex1.W.LB

- 1-channel isolated barrier
- Universal usage at different power supplies
- Dry contact or NAMUR inputs
- Relay contact output
- Fault relay contact output
- Line fault detection (LFD)
- Reversible mode of operation
- Up to SIL 2 (SC 3) acc. to IEC/EN 61508



Function

This isolated barrier is used for intrinsic safety applications. It transfers digital signals (NAMUR sensors/mechanical contacts) from a hazardous area to a safe area. The proximity sensor or switch controls a form C changeover relay contact for the safe area load. The normal output state can be reversed using switch S1. Switch S2 allows output II to be switched between a signal output or an error message output. Switch S3 is used to enable or disable line fault detection of the field circuit. During an error condition, relays revert to their de-energized state and LEDs indicate the fault according to NAMUR NE44.

Connection

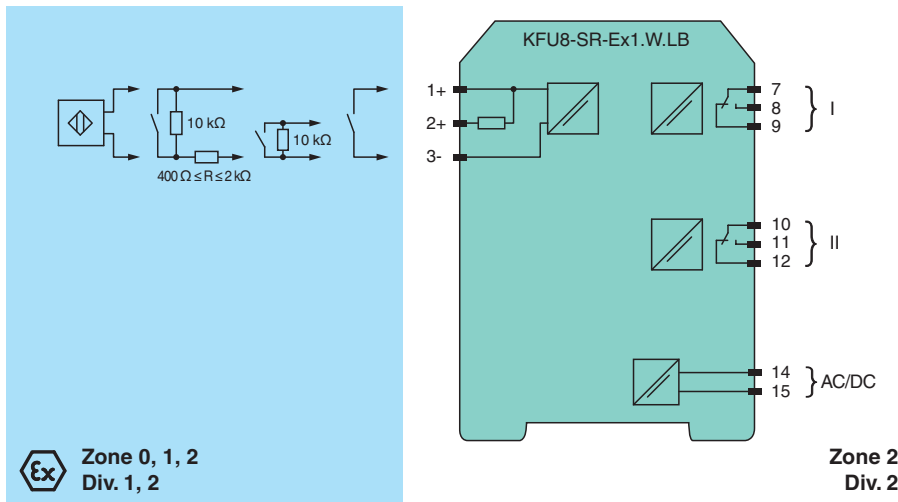

Technical Data

General specifications	
Signal type	Digital Input
Functional safety related parameters	
Safety Integrity Level (SIL)	SIL 2
Systematic capability (SC)	SC 3
Supply	
Connection	terminals 14, 15
Rated voltage	U_r 19 ... 30 V DC / 90 ... 253 V AC 50 ... 60 Hz
Power dissipation/power consumption	≤ 1.2 W / ≤ 1.2 W ; 3.4 VA
Input	
Connection side	field side

Release date: 2023-01-03 Date of issue: 2023-01-03 Filename: 204138_eng.pdf

Technical Data

Connection	terminals 1+, 2+, 3-	
Rated values	acc. to EN 60947-5-6 (NAMUR)	
Open circuit voltage/short-circuit current	approx. 8 V DC / approx. 8 mA	
Switching point/switching hysteresis	1.2 ... 2.1 mA / approx. 0.2 mA	
Line fault detection	breakage $I \leq 0.1$ mA , short-circuit $I > 6$ mA	
Pulse/Pause ratio	min. 20 ms / min. 20 ms	
Output		
Connection side	control side	
Connection	output I: terminals 7, 8, 9 ; output II: terminals 10, 11, 12	
Output I	signal ; relay	
Output II	signal or fault message ; relay	
Contact loading	250 V AC/2 A/cos $\phi > 0.75$; 126.5 V AC/4 A/cos $\phi > 0.75$; 40 V DC/2 A resistive load	
Minimum switch current	2 mA / 24 V DC	
Energized/De-energized delay	approx. 20 ms / approx. 20 ms	
Mechanical life	10^7 switching cycles	
Transfer characteristics		
Switching frequency	≤ 10 Hz	
Galvanic isolation		
Input/Output	reinforced insulation according to IEC/EN 61010-1, rated insulation voltage 300 V _{eff}	
Input/power supply	reinforced insulation according to IEC/EN 61010-1, rated insulation voltage 300 V _{eff}	
Output/power supply	reinforced insulation according to IEC/EN 61010-1, rated insulation voltage 300 V _{eff}	
Output/Output	reinforced insulation according to IEC/EN 61010-1, rated insulation voltage 300 V _{eff}	
Indicators/settings		
Display elements	LEDs	
Control elements	DIP switch	
Configuration	via DIP switches	
Labeling	space for labeling at the front	
Directive conformity		
Electromagnetic compatibility		
Directive 2014/30/EU	EN 61326-1:2013 (industrial locations)	
Low voltage		
Directive 2014/35/EU	EN 61010-1:2010+A1:2019+A1:2019/AC:2019	
Conformity		
Electromagnetic compatibility	NE 21:2017 , EN 61326-3-1:2017 , EN IEC 61326-3-2:2018 , EN IEC 61326-1:2021 (industrial locations)	
Degree of protection	IEC 60529:1989+A1:1999+A2:2013	
Input	EN 60947-5-6:2000	
Ambient conditions		
Ambient temperature	-40 ... 60 °C (-40 ... 140 °F) extended ambient temperature range up to 70 °C (158 °F), refer to manual for necessary mounting conditions	
Mechanical specifications		
Degree of protection	IP20	
Connection	screw terminals	
Mass	approx. 150 g	
Dimensions	20 x 119 x 115 mm (0.8 x 4.7 x 4.5 inch) (W x H x D) , housing type B2	
Mounting	on 35 mm DIN mounting rail acc. to EN 60715:2001	
Data for application in connection with hazardous areas		
EU-type examination certificate	FIDI 22 ATEX 0029 X	
Marking	Ⓢ II 3(1)G Ex ec nC [ia Ga] IIC T4 Gc Ⓢ II (1)D [Ex ia Da] IIIC Ⓢ I (M1) [Ex ia Ma] I	
Input	Ex ia	
Voltage	U _o	10.5 V
Current	I _o	13 mA

Technical Data



Power	P _o	34 mW (linear characteristic)
Supply		
Maximum safe voltage	U _m	253 V AC (Attention! U _m is no rated voltage.)
Output		
Maximum safe voltage	U _m	253 V AC (Attention! The rated voltage can be lower.)
Galvanic isolation		
Input/Output		safe electrical isolation acc. to IEC/EN 60079-11, voltage peak value 375 V
Input/power supply		safe electrical isolation acc. to IEC/EN 60079-11, voltage peak value 375 V
Directive conformity		
Directive 2014/34/EU		EN IEC 60079-0:2018 , EN 60079-7:2015+A1:2018 , EN 60079-11:2012 , EN IEC 60079-15:2019
International approvals		
UL approval		E106378
Control drawing		116-0489
Contact loading		250 V AC/2 A/cos φ > 0.75; 126.5 V AC/4 A/cos φ > 0.75; 30 V DC/2 A resistive load
IECEx approval		
IECEx certificate		IECEx FIDI 22.0003X
IECEx marking		Ex ec nC [ia Ga] IIC T4 Gc , [Ex ia Da] IIIC , [Ex ia Ma] I
General information		
Supplementary information		Observe the certificates, declarations of conformity, instruction manuals, and manuals where applicable. For information see www.pepperl-fuchs.com .

Assembly

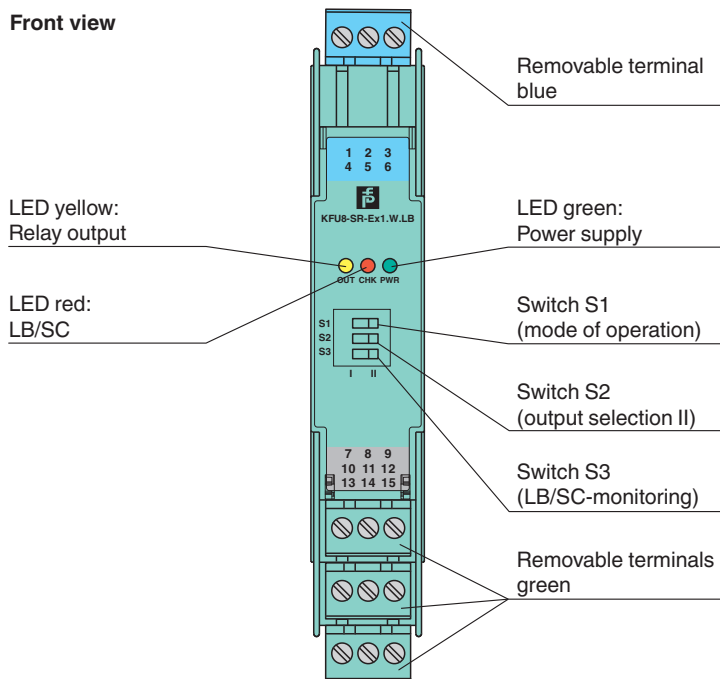
Front view



Accessories

	KF-ST-5GN	Terminal block for KF modules, 3-pin screw terminal, green
	KF-ST-5BU	Terminal block for KF modules, 3-pin screw terminal, blue

Release date: 2023-01-03 Date of issue: 2023-01-03 Filename: 204138_eng.pdf

Accessories

	KF-CP	Red coding pins, packaging unit: 20 x 6
---	--------------	---

Configuration

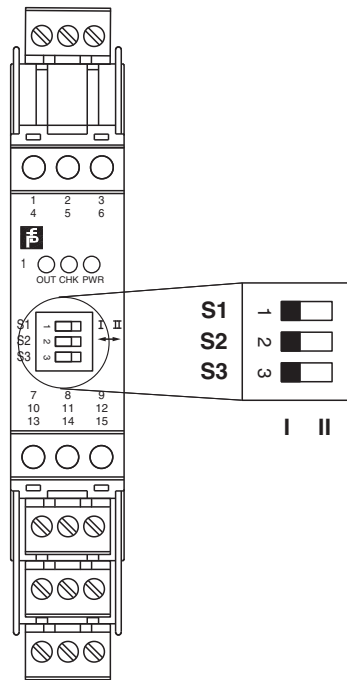

Switch position

S	Function		Position
1	Mode of operation output I (relay) energized	with high input current	I
		with low input current	II
2	Assignment output II (relay)	Switching state like output I	I
		Fault indication output (de-energized if fault)	II
3	Line fault detection	ON	I
		OFF	II

Operating states

Control circuit	Input signal
Initiator high impedance/contact opened	low input current
Initiator low impedance/contact closed	high input current
Lead breakage, lead short circuit	Line fault

Factory setting: switch 1, 2 and 3 in position I

Characteristic Curve

Maximum switching power of output contacts

Release date: 2023-01-03 Date of issue: 2023-01-03 Filename: 204138_eng.pdf

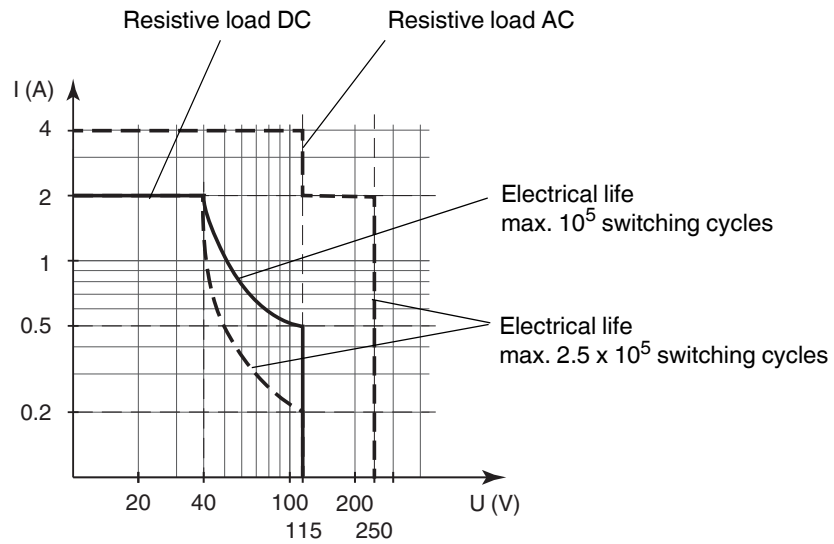

The maximum number of switching cycles is depending on the electrical load and may be higher when reduced currents and voltages are applied.