

Ultrasonic sensor

UB800-18GM40-I-V1

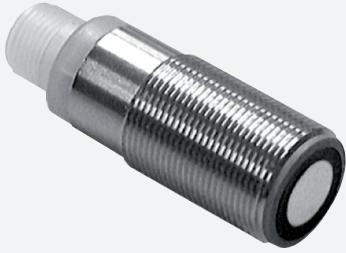

- Short design, 40 mm
- Function indicators visible from all directions
- Analog output 4 mA ... 20 mA
- Measuring window adjustable
- Program input
- Temperature compensation

Single head system



Dimensions

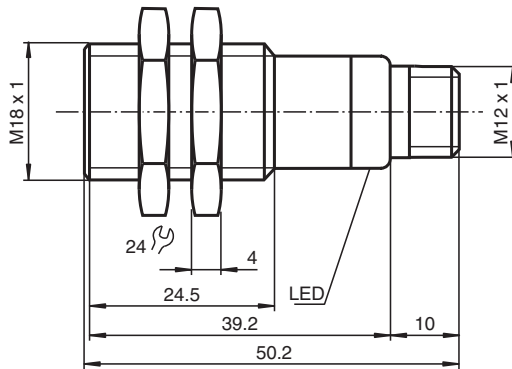

Technical Data

General specifications

Sensing range	50 ... 800 mm
Adjustment range	70 ... 800 mm
Dead band	0 ... 50 mm
Standard target plate	100 mm x 100 mm
Transducer frequency	approx. 255 kHz
Response delay	approx. 100 ms

Indicators/operating means

LED green	Power on
-----------	----------

Technical Data

LED yellow	solid yellow: object in the evaluation range yellow, flashing: program function, object detected	
LED red	solid red: Error red, flashing: program function, object not detected	
Electrical specifications		
Operating voltage	U_B	10 ... 30 V DC , ripple 10 % _{SS}
No-load supply current	I_0	≤ 20 mA
Input		
Input type	1 program input lower evaluation limit A1: $-U_B \dots +1$ V, upper evaluation limit A2: $+4$ V ... $+U_B$ input impedance: > 4.7 kΩ, pulse duration: ≥ 1 s	
Output		
Output type	1 analog output 4 ... 20 mA, short-circuit/overload protected	
Default setting	evaluation limit A1: 70 mm evaluation limit A2: 800 mm	
Resolution	0.4 mm at max. sensing range	
Deviation of the characteristic curve	± 1 % of full-scale value	
Repeat accuracy	± 0.5 % of full-scale value	
Load impedance	0 ... 300 Ω at $U_B > 10$ V; 0 ... 500 Ω at $U_B > 15$ V	
Temperature influence	± 1.5 % of full-scale value	
Compliance with standards and directives		
Standard conformity		
Standards	EN IEC 60947-5-2:2020 IEC 60947-5-2:2019 EN 60947-5-7:2003 IEC 60947-5-7:2003	
Approvals and certificates		
UL approval	cULus Listed, Class 2 Power Source	
CCC approval	CCC approval / marking not required for products rated ≤36 V	
Ambient conditions		
Ambient temperature	-25 ... 70 °C (-13 ... 158 °F)	
Storage temperature	-40 ... 85 °C (-40 ... 185 °F)	
Mechanical specifications		
Connection type	Connector plug M12 x 1 , 4-pin	
Degree of protection	IP67	
Material		
Housing	brass, nickel-plated	
Transducer	epoxy resin/hollow glass sphere mixture; foam polyurethane, cover PBT	
Mass	25 g	
Dimensions		
Length	40 mm	
Diameter	18 mm	

Connection Assignment

Standard symbol/Connections:
(version I)

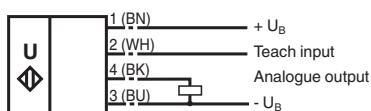

Core colours in accordance with EN 60947-5-2.

Release date: 2025-05-16 Date of issue: 2025-05-16 Filename: 205340_eng.pdf

Connection Assignment



Wire colors in accordance with EN 60947-5-2

1	BN	(brown)
2	WH	(white)
3	BU	(blue)
4	BK	(black)

Characteristic Curve

Characteristic response curve

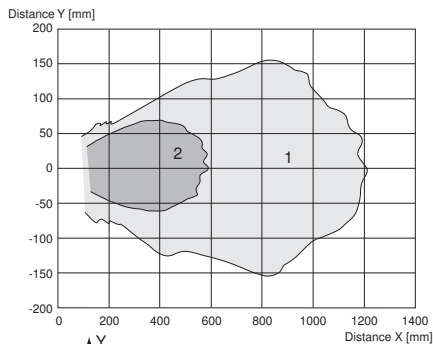

Curve 1: flat surface 100 mm x 100 mm
Curve 2: round bar, Ø 25 mm

Programmed analogue output function

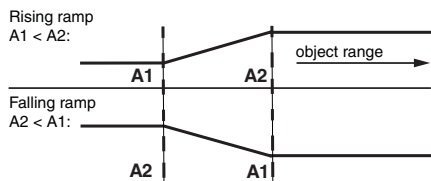

A1 -> ∞, A2 -> ∞: Detection of object presence

Object detected: 20 mA
No object detected: 4 mA

Release date: 2025-05-16 Date of issue: 2025-05-16 Filename: 205340_eng.pdf

Programming

Programming procedure

The sensor features a programmable analog output with two programmable evaluation boundaries. Programming the evaluation boundaries and the operating mode is done by applying the supply voltage $-U_B$ or $+U_B$ to the Teach-In input. The supply voltage must be applied to the Teach-In input for at least 1 s. LEDs indicate whether the sensor has recognized the target during the programming procedure.

Note:

Evaluation boundaries may only be specified directly after Power on. A time lock secures the adjusted switching points against unintended modification 5 minutes after Power on. To modify the evaluation boundaries later, the user may specify the desired values only after a new Power On.

Note:

If a programming adapter UB-PROG2 is used for the programming procedure, button A1 is assigned to $-U_B$ and button A2 is assigned to $+U_B$.

Programming the analog output

Rising ramp

1. Place the target at the near end of the desired evaluation range
2. Program the evaluation boundary by applying $-U_B$ to the Teach-In input (yellow LED flashes)
3. Disconnect the Teach-In input from $-U_B$ to save the evaluation boundary
4. Place the target at the far end of the desired evaluation range
5. Program the evaluation boundary by applying $+U_B$ to the Teach-In input (yellow LED flashes)
6. Disconnect the Teach-In input from $+U_B$ to save the evaluation boundary

Falling ramp

1. Place the target at the far end of the desired evaluation range
2. Program the evaluation boundary by applying $-U_B$ to the Teach-In input (yellow LED flashes)
3. Disconnect the Teach-In input from $-U_B$ to save the evaluation boundary
4. Place the target at the near end of the desired evaluation range
5. Program the evaluation boundary by applying $+U_B$ to the Teach-In input (yellow LED flashes)
6. Disconnect the Teach-In input from $+U_B$ to save the evaluation boundary

Installation Conditions

If the sensor is installed at places, where the environment temperature can fall below 0 °C, for the sensors fixation, one of the mounting flanges BF18, BF18-F or BF 5-30 must be used.

In case of direct mounting of the sensor in a through hole using the steel nuts, it has to be fixed at the middle of the housing thread. If a fixation at the front end of the threaded housing is required, plastic nuts with centering ring (accessories) must be used.