

Retroreflective sensor

GLV18-55-G/59/102/115

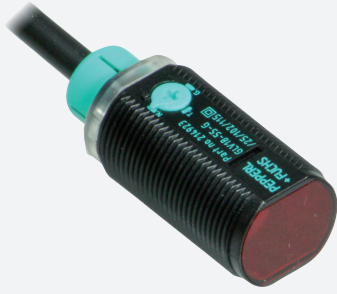

- Efficient Line in a short M18 plastic housing for standard applications
- Two devices in one: choice of either clear object detection or retroreflective operating mode with a large detection range
- 4 LEDs indicator for 360° visibility
- Optimized potentiometer design for a clear control button layout in the application
- DC voltage version

Retroreflective sensor for glass detection, M18 threaded housing design, plastic housing, front optical face, 2.5 m detection range, red light, dark on, DC version, NPN output, fixed cable



Function

The GLV/GLK18 series sensors help improve the efficiency of machines and systems. The design of the M18 plastic housing, the connection technology, and sensor properties are highly standardized. Concentrating on the key sensor requirements has produced a robust and reliable product series for DC and AC/DC voltage systems without any over-engineering. The mounting set included in the scope of delivery and the optimized potentiometer design ensure fast assembly and easy configuration.

Application

Packaging industry:

- Presence checks, track loading, completeness checks, stack height control

Material handling:

- Presence checks, target sensor, profile checks, trigger sensor

Automatic doors, gates and access systems, elevator:

- Secure detection for automatic door and gate systems
- Monitoring function in turnstiles
- Closing edge monitoring in elevators

Dimensions

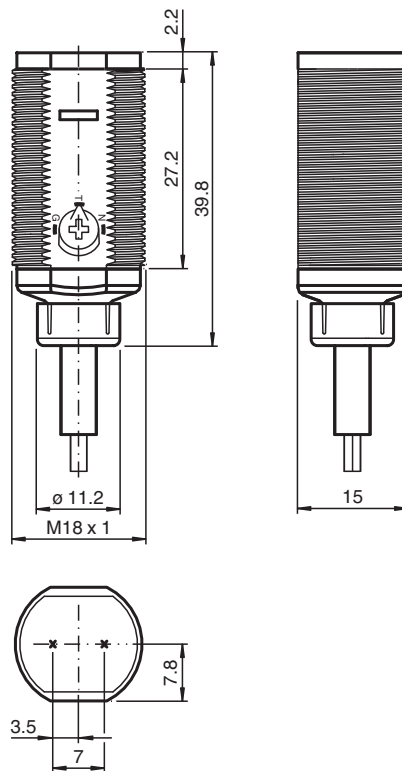

Technical Data

General specifications

Effective detection range	0 ... 2.5 m in glass mode; 0 ... 5 m in normal mode
Reflector distance	0 ... 2.5 m in glass mode; 0 ... 5 m in normal mode
Threshold detection range	6.5 m
Reference target	reflector C110-2
Light source	LED
Light type	modulated visible red light , 640 nm
Polarization filter	yes
Diameter of the light spot	approx. 370 mm at 6.5 m ; 50 mm at 1 m
Opening angle	approx. 2 °
Optical face	frontal
Ambient light limit	30000 Lux

Functional safety related parameters

MTTF _d	1260 a
Mission Time (T _M)	20 a
Diagnostic Coverage (DC)	0 %

Indicators/operating means

Operation indicator	LED green, statically lit Power on, blinking with 2 Hz or 4 Hz in Teach-In mode
Function indicator	LED yellow: In retro-reflective mode: Lights up when light beam is free; flashing if signal is short of function reserve, off when light beam is interrupted In glass-mode: Lights up when light beam is free; flashing if further compensation is impossible; off when light beam is interrupted
Control elements	potentiometer for Teach-In and Mode selection

Technical Data

Contrast detection levels		18 % - clear glass bottles
Electrical specifications		
Operating voltage	U_B	10 ... 30 V DC
No-load supply current	I_0	< 15 mA
Output		
Switching type		dark-on
Signal output		1 NPN, short-circuit protected open collector
Switching voltage		max. 30 V DC
Switching current		max. 100 mA
Voltage drop	U_d	≤ 1.5 V DC
Switching frequency	f	1 kHz
Response time		≤ 0.5 ms
Conformity		
Product standard		EN 60947-5-2
Approvals and certificates		
EAC conformity		TR CU 020/2011
Protection class		II, Rated insulation voltage ≤ 50 V AC with pollution degree 1-2 according to IEC 60664-1
UL approval		cULus Listed, Class 2 Power Source
CCC approval		CCC approval / marking not required for products rated ≤ 36 V
Ambient conditions		
Ambient temperature		-25 ... 60 °C (-13 ... 140 °F)
Storage temperature		-40 ... 70 °C (-40 ... 158 °F)
Mechanical specifications		
Degree of protection		IP67
Connection		2 m fixed cable
Material		
Housing		PC
Optical face		PMMA
Cable		PVC
Mass		approx. 75 g

Connection Assignment

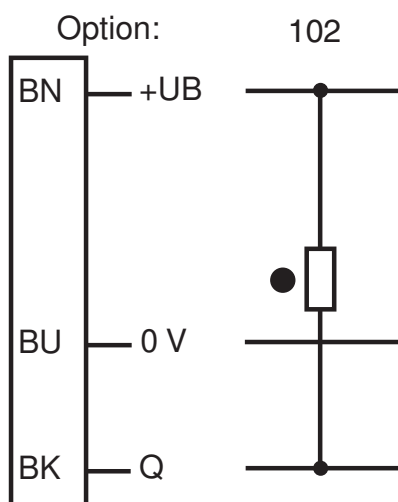

Connection

Connect the device as set out in the connection diagram.

- = Light on
- = Dark on

Assembly

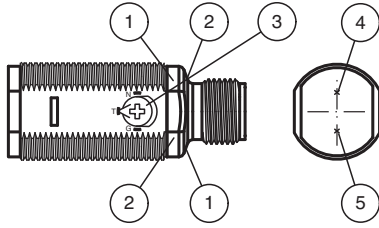

1	Operating display	green
2	Signal display	yellow
3	Potentiometer Teach-In and Mode selection	
	N	Normal mode
	T	Teach-In Mode
	G	Glas mode
4	Emitter	
5	Receiver	

Installation

Mounting

Sensor: The sensors have an M18 x 1 threaded housing design and nuts or a mounting ring. The sensors can be mounted directly through a simple Ø 18 mm hole, or using a mounting bracket. Mounting brackets are available as accessories. Pay careful attention to the position and visibility of the programming interface or signal indicators during mounting.

Aligning the sensor: Apply the operating voltage to the sensor. The operating indicator lights up green. The sensor is automatically set to maximum sensitivity (default setting), or to the last teach-in setting. Mount a suitable reflector opposite the light barrier.

Switch position "N": Align the sensor with the reflector so that the yellow signal indicator lights up continuously.

Characteristic Curve

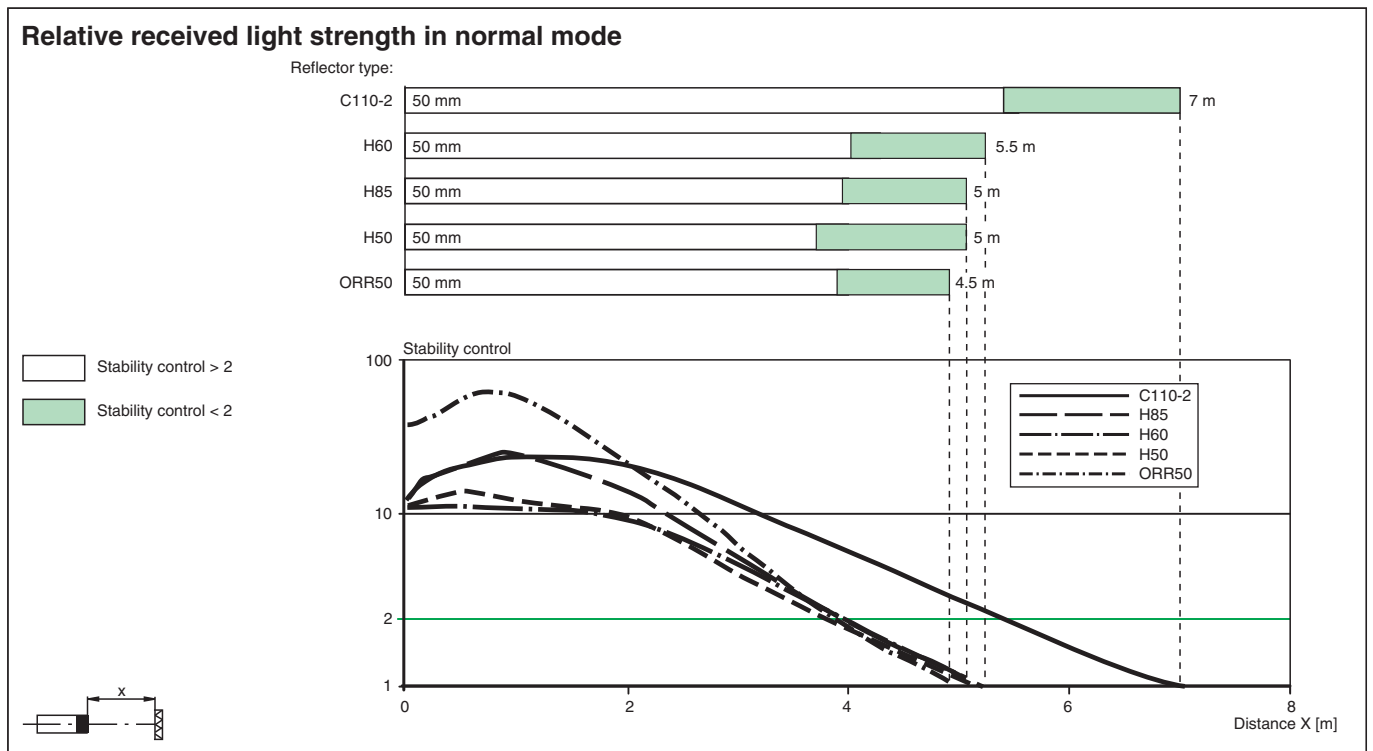

Release date: 2022-08-08 Date of issue: 2022-08-08 Filename: 214924_eng.pdf

Characteristic Curve

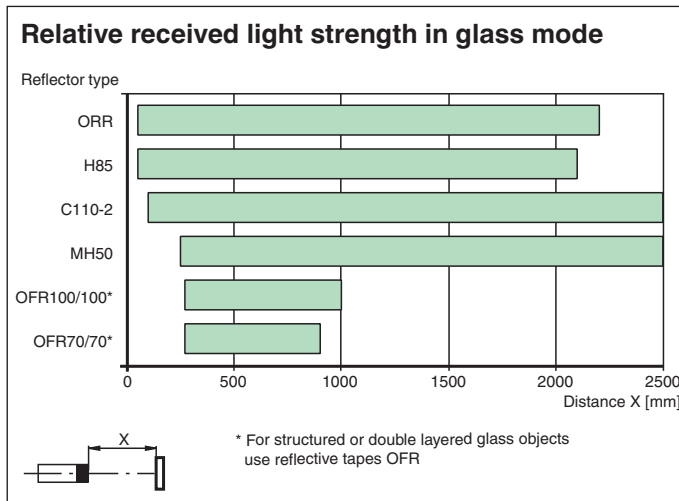

System Description

System Description

A retroreflective sensor contains emitters and receivers integrated in a single housing. The emitted light is reflected back to the receiver by a reflector. When the light beam is interrupted by an object, the switching function is triggered.

This sensor has two operating modes:

- **Normal "N"**: In "N" mode, the retroreflective sensor has a long detection range.
- **Glass detection "G"**: Operating mode "G" is used specifically for glass detection. The switching threshold is automatically adjusted in the event of contamination.

Commissioning

Switch Position "N" (Normal Operation)

The switch is in "N" position. The yellow signal indicator lights up continuously when the light beam is clear.

Position the object in the beam path of the sensor.

When the object is detected, the yellow signal indicator goes out. After the object has been removed, the yellow signal indicator lights up again continuously.

Switch Position "T" (Teach-In Mode)

The yellow signal indicator lights up continuously when the light beam is clear.

Set the switch to the "T" position when the light beam is free and wait approx. 2 seconds until the yellow and green signal indicators flash (2.5 Hz).

For clear glass detection mode, turn the switch to switch position "G".

Teach-in successful: The green and yellow signal indicators light up. Contrast detection is activated. The device is ready for operation. Place the object to be detected into the beam. When the object is detected, the yellow signal indicator goes out.

Teach-in unsuccessful: The green and yellow signal indicators flash quickly in alternation (approx. 8 Hz) for approx. 5 seconds. The sensor is then set to maximum sensitivity. Repeat the teach-in process.





Maintenance

Maintenance



Cleaning: If the transmission/reception deteriorates, e.g., due to dirt, the yellow signal indicator flashes quickly (4 Hz). Clean the optical interfaces of the sensor (e.g., lenses) at regular intervals. The sensor adjusts itself automatically after cleaning. This may take up to 4 seconds in clear glass detection mode.

Maintenance: Check the mounting fittings and electrical connections regularly.

Accessories

	CPZ18B03	Mounting Bracket with swivel nut
	BF 18	Mounting flange, 18 mm
	BF 18-F	Plastic mounting adapter, 18 mm
	BF 5-30	Universal mounting bracket for cylindrical sensors with a diameter of 5 ... 30 mm
	REF-C110-2	Reflector, round ø 84 mm, central mounting hole

Accessories

	REF-H60	Reflector, rectangular 40.3 mm x 59.9 mm, mounting holes
	REF-H50	Reflector, rectangular 51 mm x 61 mm, mounting holes, fixing strap