



WIS module primary

NDP-KE2-8E2-FP

- 8 channels
- 9 outputs
- LEDs for display of the output states and communication
- Deactivation option
- Housing with removable terminals
- DIN rail mounting
- For connection of 1 transmitter head
- Can only be used in conjunction with NDP20-FP series WIS transmitter

Inductive transmitter system



Dimensions

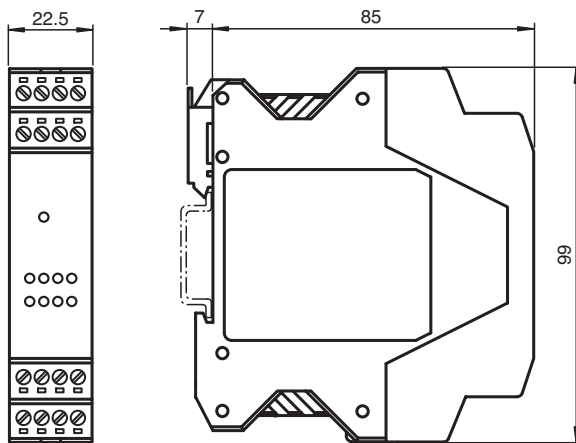

Technical Data

Nominal ratings

Operating voltage	U_B	24 V DC \pm 10 %
Number of signal channels		8
Signal transfer direction		from secondary side to primary side
Reverse polarity protection		reverse polarity protected
Current consumption		max. 1000 mA

Functional safety related parameters

MTTF _d		245 a
Mission Time (T _M)		20 a
Diagnostic Coverage (DC)		0 %

Indicators/operating means

Switching state		8 x LED, yellow
Transfer indicator	Tx	LED, green

Input

Number		1
Input type		Activation input signal level: \geq 15 V = active, \leq 3 V inactive

Release date: 2024-05-28 Date of issue: 2024-06-06 Filename: 221418_eng.pdf

Technical Data

Input current		$\leq 1 \text{ mA}$
Internal resistor		$\geq 15 \text{ k}\Omega$
Output		
Output type		1 Status output (high with proper transfer) and 8 Switch outputs PNP, NO. (switched high) , overload and short-circuit resistant
Voltage drop	U_d	$\leq 2.5 \text{ V}$
Load current		max. 50 mA
Response time		$\leq 200 \text{ ms}$ (static operation , the transmission heads stand opposite to each other)
Compliance with standards and directives		
Directive conformity		
EMC Directive 89/336/EEC		EN 61000-6-2:2001, EN 61000-6-4:2001, EN 50295:1999
Standard conformity		
Standards		EN IEC 60947-5-2
Approvals and certificates		
CCC approval		CCC approval / marking not required for products rated $\leq 36 \text{ V}$
Ambient conditions		
Ambient temperature		0 ... 50 °C (32 ... 122 °F)
Storage temperature		-25 ... 85 °C (-13 ... 185 °F)
Mechanical specifications		
Degree of protection		IP20
Material		
Housing		PA 66-FR
Installation		DIN rail mounting
Mass		106 g
General information		
Note		Maximum cable length between WIS module and WIS transmitter must not exceed 5 m.

Connection

Connection:

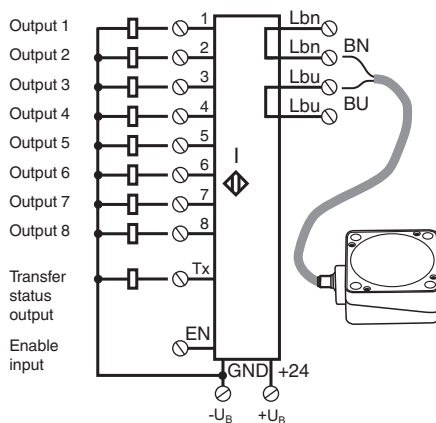

Function

Functional description

A WIS (wireless inductive system) inductive transfer system always consists of the following four components:

- WIS primary module
- WIS primary transmitter
- WIS secondary transmitter
- WIS secondary module

The WIS primary module is installed in the stationary component and is connected to a downstream control (i.e., PLC). The WIS primary transmitter connected to the WIS primary module. The WIS secondary transmitter and the WIS secondary module that is connected to it are installed in the moveable part of the component. The WIS secondary module disposes of connection capabilities for several sensors. If the two transmitters are located in front of each other within the system range, then electric power is transferred from the primary side to the secondary side. The sensors attached to the WIS secondary module are now supplied with electric energy and begin to operate. The sensor output signals are transmitted in the opposite direction from the secondary side to the primary side and are separately available on the WIS primary module output terminals for further processing by the equipment control. The sensor signal status is also displayed by LEDs that correspond to the sensor channels. A separate output signal Tx on the WIS primary module indicates the communication status. A high signal indicates communication between the WIS transmitters. This is also indicated by a glowing LED Tx.

Power transfer and communication in the system can be activated and deactivated on the WIS primary module with the EN input .

Input signal on EN	Function
+ UB (24 V DC)	Transfer activated
GND or open.	Transfer deactivated

Function schematic

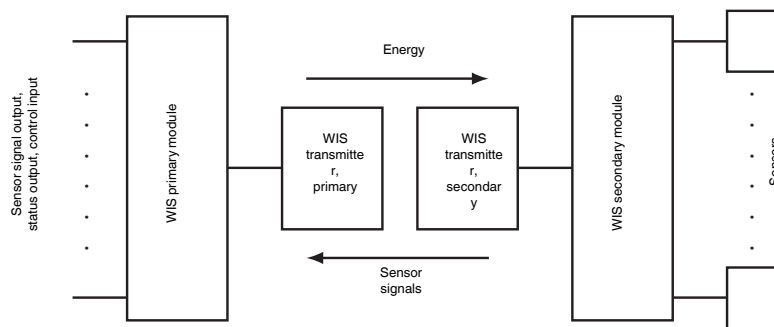

The sum of the currents of all sensors attached to the WIS secondary module must not be greater than the maximum transferable current. This is calculated by dividing the transferable power by the 12 V provided by the transmitters.