



# Switch Amplifier

## HiC2832

- 2-channel isolated barrier
- 24 V DC supply (bus powered)
- Dry contact or NAMUR inputs
- 2 passive transistor outputs (resistive acc. to EN 60947-5-6)
- Line fault detection (LFD)
- Line fault transparency (LFT)
- Reversible mode of operation
- Up to SIL 2 (SC 3) acc. to IEC/EN 61508



### Function

This isolated barrier is used for intrinsic safety applications.

The device transfers digital signals (NAMUR sensors/mechanical contacts) from the explosion-hazardous area to the non-explosion-hazardous area.

Each input controls a passive transistor output with a resistive output characteristic (acc. to EN60947-5-6).

The outputs have three defined states: 1-signal = 1.8 kΩ, 0-signal = 14 kΩ and fault > 100 kΩ.

This output characteristic offers line fault transparency on the signal lines.

Via switches the mode of operation can be reversed and the line fault detection can be switched off.

During a fault state, the passive transistor outputs switch to their fault state and LEDs indicate the fault according to NAMUR NE 44. A separate fault bus is available. This fault bus can be monitored if the termination board supports a module fault detection.

This device mounts on a HiC termination board.

### Connection

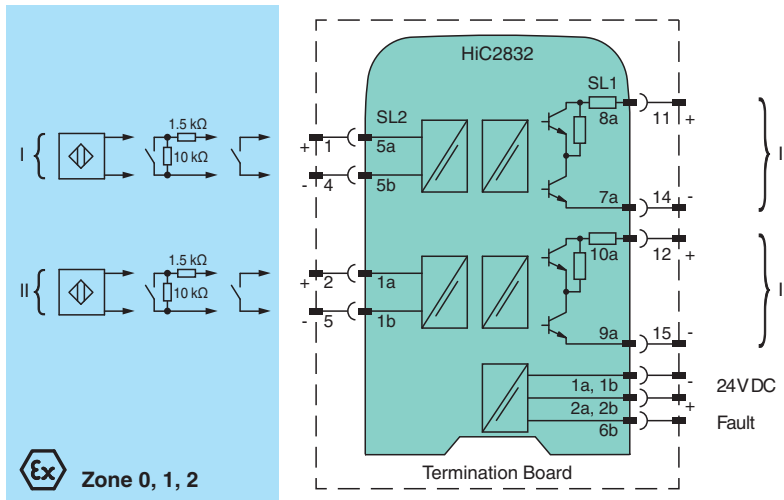

### Technical Data

General specifications	
Signal type	Digital Input
Functional safety related parameters	
Safety Integrity Level (SIL)	SIL 2
Systematic capability (SC)	SC 3
Supply	
Connection	SL1: 1a(-), 1b(-); 2a(+), 2b(+)
Rated voltage	U <sub>r</sub> 19 ... 30 V DC bus powered via Termination Board

Release date: 2023-06-05 Date of issue: 2023-06-05 Filename: 226429\_eng.pdf

## Technical Data

Ripple		≤ 10 %
Rated current	$I_r$	≤ 30 mA
Power dissipation		≤ 600 mW
Power consumption		≤ 700 mW
<b>Input</b>		
Connection side		field side
Connection		SL2: 5a(+), 5b(-); 1a(+), 1b(-)
Rated values		acc. to EN 60947-5-6 (NAMUR), see manual for electrical data
Open circuit voltage/short-circuit current		approx. 10 V DC / approx. 8 mA
Switching point/switching hysteresis		1.2 ... 2.1 mA / approx. 0.2 mA
Line fault detection		breakage $I \leq 0.1$ mA , short-circuit $I \geq 6.5$ mA
Pulse/Pause ratio		min. 100 $\mu$ s / min. 100 $\mu$ s
<b>Output</b>		
Connection side		control side
Connection		SL1: 8a(+), 7a(-); 10a(+), 9a(-)
Rated voltage	$U_r$	8 V DC
Response time		≤ 200 $\mu$ s
Output I, II		signal or fault message, passive transistor output (resistive) 0-signal: 14 k $\Omega$ $\pm$ 10 % 1-signal: 1.8 k $\Omega$ $\pm$ 10 % fault: > 100 k $\Omega$
<b>Fault indication output</b>		
Connection		SL1: 6b
Output type		open collector transistor (internal fault bus)
<b>Transfer characteristics</b>		
Switching frequency		≤ 5 kHz
<b>Galvanic isolation</b>		
Output/power supply		basic insulation according to IEC/EN 61010-1, rated insulation voltage 60 V <sub>eff</sub>
Output/Output		basic insulation according to IEC/EN 61010-1, rated insulation voltage 60 V <sub>eff</sub>
<b>Indicators/settings</b>		
Display elements		LEDs
Control elements		DIP switch
Configuration		via DIP switches
Labeling		space for labeling at the front
<b>Directive conformity</b>		
Electromagnetic compatibility		
Directive 2014/30/EU		EN 61326-1:2013 (industrial locations)
<b>Conformity</b>		
Electromagnetic compatibility		EN IEC 61326-3-2:2018 , NE 21:2017 For further information see system description.
Degree of protection		IEC 60529:2001
Protection against electrical shock		IEC 61010-1
<b>Ambient conditions</b>		
Ambient temperature		-40 ... 70 °C (-40 ... 158 °F)
<b>Mechanical specifications</b>		
Degree of protection		IP20
Mass		approx. 100 g
Dimensions		12.5 x 106 x 128 mm (0.5 x 4.2 x 5.1 inch) (W x H x D)
Mounting		on termination board
Coding		pin 1 and 2 trimmed For further information see system description.
<b>Data for application in connection with hazardous areas</b>		
EU-type examination certificate		BVS 11 ATEX E 026
Marking		Ⓜ II (1)G [Ex ia Ga] IIC Ⓜ II (1)D [Ex ia Da] IIIC Ⓜ I (M1) [Ex ia Ma] I

## Technical Data

Input	Ex ia	
Voltage	$U_o$	10.5 V
Current	$I_o$	17.1 mA
Power	$P_o$	45 mW (linear characteristic)
Supply		
Maximum safe voltage	$U_m$	253 V AC (Attention! $U_m$ is no rated voltage.)
Output		
Maximum safe voltage	$U_m$	253 V AC (Attention! $U_m$ is no rated voltage.)
Certificate	KIWA 15 ATEX 0037 X	
Marking	Ⓔ II 3G Ex ec IIC T4 Gc	
Galvanic isolation		
Input/Output	safe electrical isolation acc. to IEC/EN 60079-11, voltage peak value 375 V	
Input/power supply	safe electrical isolation acc. to IEC/EN 60079-11, voltage peak value 375 V	
Directive conformity		
Directive 2014/34/EU	EN IEC 60079-0:2018+AC:2020 , EN 60079-11:2012 , EN 60079-7:2015+A1:2018 , EN 50303:2000	
International approvals		
FM approval		
Control drawing	116-0430 (cFMus)	
UL approval		
Control drawing	E106378	
IECEX approval		
IECEX certificate	IECEX BVS 11.0040 IECEX KIWA 15.0019X	
IECEX marking	[Ex ia Ga] IIC , [Ex ia Da] IIIC , [Ex ia Ma] I , Ex ec IIC T4 Gc	
General information		
Supplementary information	Observe the certificates, declarations of conformity, instruction manuals, and manuals where applicable. For information see <a href="http://www.pepperl-fuchs.com">www.pepperl-fuchs.com</a> .	

## Assembly

### Front view

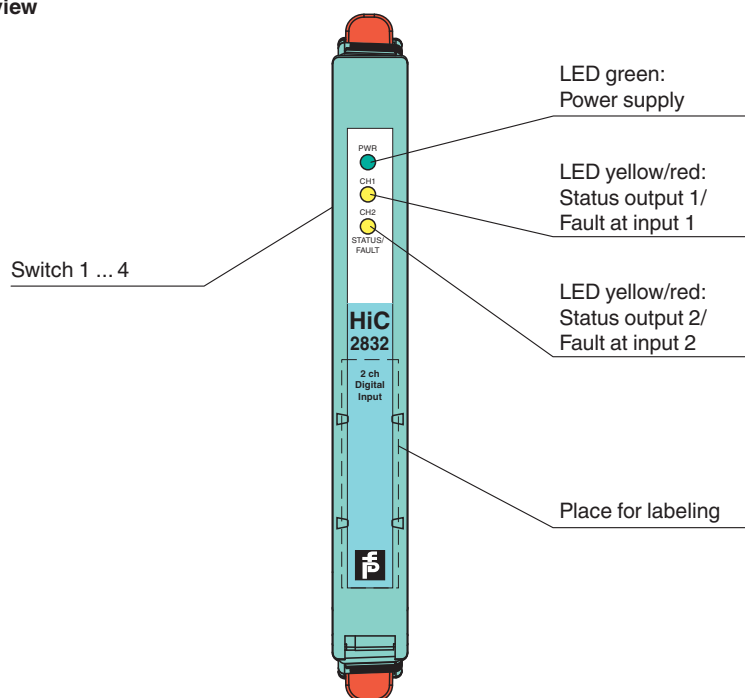

## Configuration

Configure the device in the following way:

- Push the red Quick Lok Bars on each side of the device in the upper position.
- Remove the device from termination board.
- Set the switches according to the figure in the **Configuration** section.

### Note

The pins for this device are trimmed to polarize it according to its safety parameters. Do not change the setting. For further information see system description.

**Configuration**

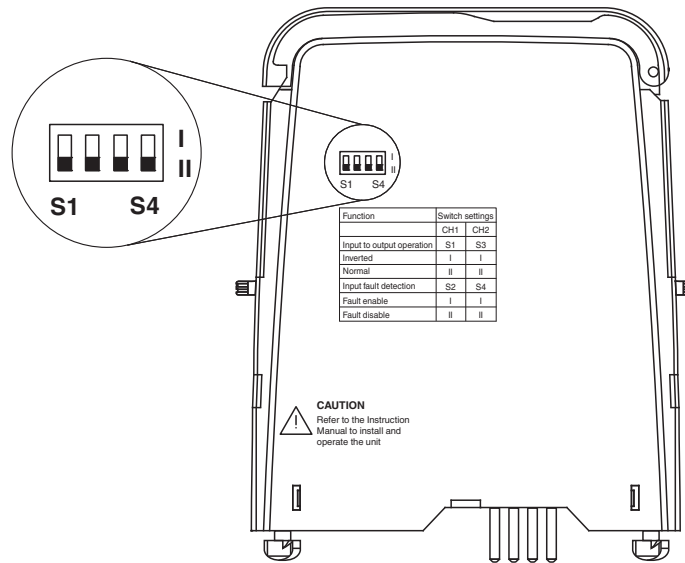

**Switch settings**

S	Channel	Function	Position	
1	I	Mode of operation	Inverted	I
			Normal	II
2	I	Input line fault detection	ON	I
			OFF	II
3	II	Mode of operation	Inverted	I
			Normal	II
4	II	Input line fault detection	ON	I
			OFF	II

**Characteristic Curve**

**Switching points**

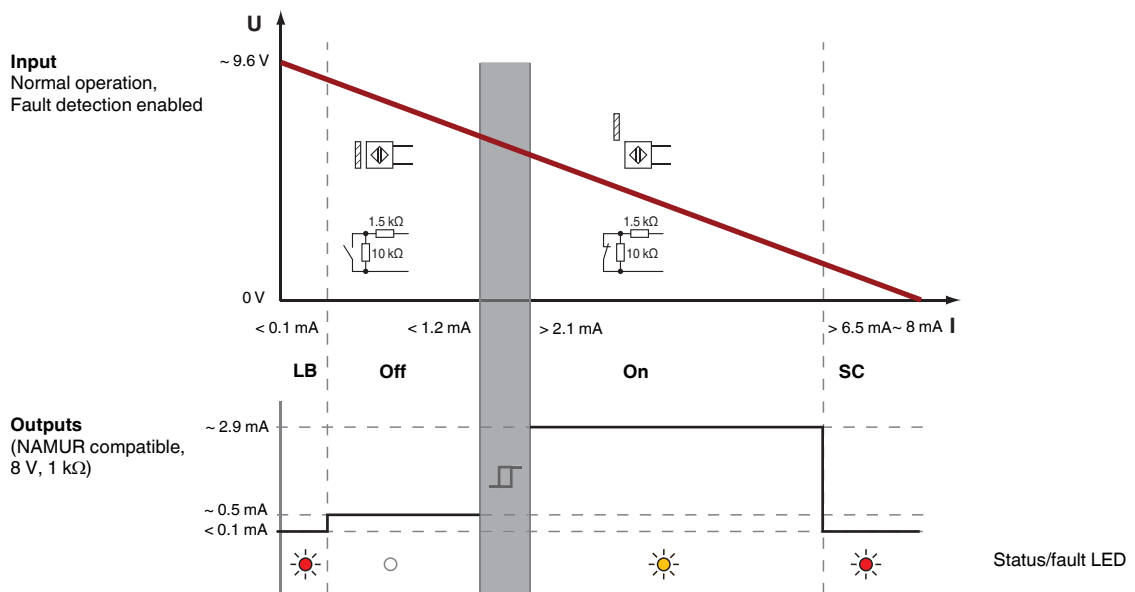

Release date: 2023-06-05 Date of issue: 2023-06-05 Filename: 226429\_eng.pdf