



# HART MUX Primary Module

## KFD2-HMM-16

- 16-channel
- 24 V DC supply (Power Rail)
- HART field device input (revision 5 to 7)
- Up to 15 KFD0-HMS-16 HART MUX secondary modules can be connected
- Up to SIL 3 acc. to IEC/EN 61508

### HART MUX Primary Module



### Function

The HART MUX primary module operates up to 256 analog field devices. The built-in secondary module in the primary module operates the first 16 field devices. If more than 16 field devices are required, up to 15 additional HART MUX secondary modules KFD0-HMS-16 can be connected. The secondary modules are connected to the primary module with a 14-pin flat cable. The connector for the ribbon cable is found on the same housing side as the connectors for the interface and the power supply. The analog signals are separately linked via a 26-pin flat cable to each secondary module. Sixteen leads are reserved for the HART signal of the analog measurement circuits. The remaining 10 leads are assigned to ground. The primary module is designed with removable terminals and can be connected to the Power Rail.

### Application

The KFD2-HMM-16 is a HART MUX primary module. The built-in secondary module can operate 16 analog field devices. Up to 15 KFD0-HMS-16 secondary modules can be connected to each HART MUX primary module. The secondary modules are linked to the KFD2-HMM-16 HART MUX primary module via a 14-pin bus cable. The data of the individual filed devices is sent to a PC through an RS-485 interface. Via PC with a software such as PACTware™ or AMS, a configuration of the HART compatible field devices, as well as the registration of the processes with regard to a maintenance system can be carried out.

### Connection

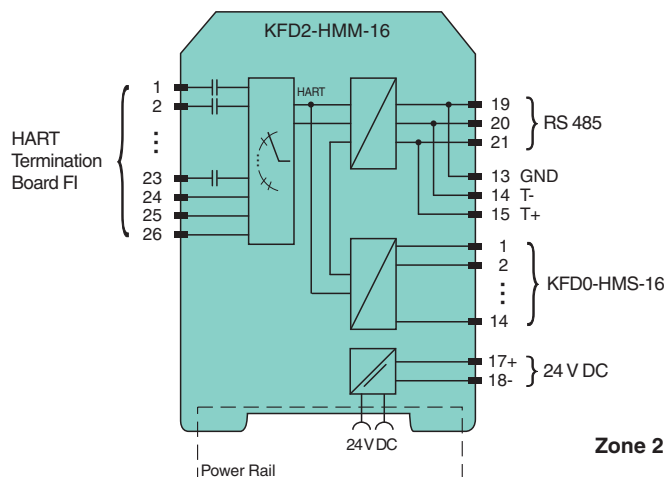

### Technical Data

#### Functional safety related parameters

Safety Integrity Level (SIL) SIL 3

#### Supply

Release date: 2024-11-20 Date of issue: 2024-11-20 Filename: 231289\_eng.pdf

## Technical Data

Connection		terminals 17+, 18-
Rated voltage	$U_r$	20 ... 32 V DC typical at 100 mA
Power consumption		max. 3 W
<b>HART signal channels (non-intrinsically safe)</b>		
Conformity		HART field device input (revision 5 to 7)
Connection		26-pin flat cable for analog connections 14-pin flat cable for primary module/secondary module connection between KFD2-HMM-16 and KFD0-HMS-16
Leakage current		< 3 $\mu$ A at -20 ... 85 °C (-4 ... 185 °F)
Terminating resistor		external 230 ... 500 $\Omega$ standard (up to 1000 $\Omega$ possible)
Output voltage		$\geq$ 400 mV <sub>ss</sub> (with the terminator resistance specified above)
Output resistance		100 $\Omega$ or smaller, capacitive coupling
Input impedance		according to HART specification
Input voltage range		0.08 ... 4 V <sub>ss</sub> ; typ. $\pm$ 5.2 V as local reference
<b>Interface</b>		
Transfer rate		9600, 19200, or 38400 Bit/s (selectable with DIL switch (2 and 3) by the user)
Type		RS-485, 2-wire multidrop
Address selection		One of 31 possible addresses selectable per DIL switch (4 ... 8)
<b>Indicators/settings</b>		
Control elements		DIP switch
Configuration		via DIP switches
Labeling		space for labeling at the front
<b>Directive conformity</b>		
Electromagnetic compatibility		
Directive 2014/30/EU		EN 61326-1:2013 (industrial locations)
<b>Conformity</b>		
Degree of protection		IEC 60529:2001
<b>Ambient conditions</b>		
Ambient temperature		-20 ... 60 °C (-4 ... 140 °F)
<b>Mechanical specifications</b>		
Degree of protection		IP20
Connection		screw terminals
Mass		approx. 250 g
Dimensions		40 x 107 x 115 mm (1.6 x 4.2 x 4.5 inch) (W x H x D), housing type C1
Mounting		on 35 mm DIN mounting rail acc. to EN 60715:2001
<b>Data for application in connection with hazardous areas</b>		
Certificate		PF 07 CERT 1143 X
Marking		Ⓔ II 3G Ex nA IIC T4 Gc
Directive conformity		
Directive 2014/34/EU		EN 60079-0:2012+A11:2013, EN 60079-15:2010
<b>General information</b>		
Supplementary information		Observe the certificates, declarations of conformity, instruction manuals, and manuals where applicable. For information see <a href="http://www.pepperl-fuchs.com">www.pepperl-fuchs.com</a> .

**Assembly**

Front view

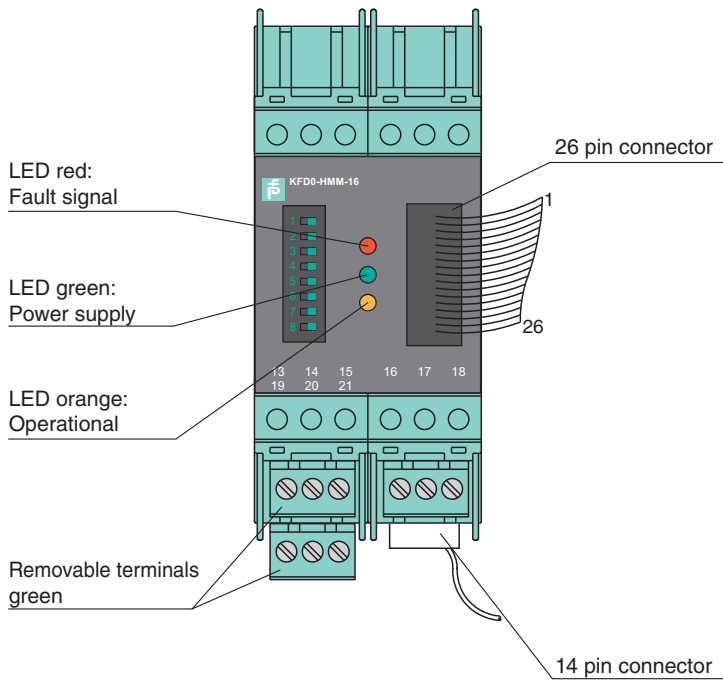

**Configuration**

**Switch Settings**

The device has 8 switches located on the top of the device. The switch 1 is used by the manufacturer for testing the device and **must therefore always be set to OFF**.

Switch	1	Meaning
Position	OFF	Normal status

The switches 2 and 3 determine the baud rate of the RS-485 interface.

Switch	2	3	Meaning
Position	OFF	OFF	9600 Baud
	OFF	ON	19200 Baud
	ON	OFF	38400 Baud
	ON	ON	not permitted

The switches 4 to 8 determine the RS-485 address. A value is assigned to each of the individual switches for this purpose. The resulting address is given by the addition of the set values.

Switch	4	5	6	7	8	Meaning
Position	ON					Value 16
		ON				Value 8
			ON			Value 4
				ON		Value 2
					ON	Value 1
Example	OFF	ON	ON	OFF	ON	Address = 8 + 4 + 1 = 13

Release date: 2024-11-20 Date of issue: 2024-11-20 Filename: 231289\_eng.pdf