



Safety control unit PSE4-SC-01



- Safety control unit
- For evaluating safety thru-beam sensors PSE4-SL
- Safety category 4 according to EN61496-1
- 24 V DC supply voltage
- 2 safe output contacts
- Performance level PLe (EN13849-1) is attainable
- Component of PSE4 modular system

Safety control unit from the PSE4 series



Dimensions



Technical Data

Limit data	
Permissible cable length	200 m
Functional safety related parameters	
Performance level (PL)	PL e
Category	Cat. 4
MTTF _d	166 a
Mission Time (T _M)	20 a
Diagnostic Coverage (DC)	99 %
Indicators/operating means	
Operation indicator	LED green: Power on

Release date: 2020-10-06 Date of issue: 2020-10-06 Filename: 233900_eng.pdf

Technical Data

Function indicator		LED green
Electrical specifications		
Operating voltage	U _B	24 V DC +20/-10 %
Power consumption	P ₀	< 4 W
Output		
Signal output		relay, 2 NO
Switching voltage		max. 250 V AC/DC
Switching current		max. 4 A
Switching power		1000 VA
Response time		32 ms
Conformity		
Functional safety		ISO 13849-1
Product standard		EN 12978 ; ISO 13856-2
Approvals and certificates		
UL approval		cULus Listed File no: NRNT.E344450
TÜV approval		TÜV Rheinland 968/M 301.00/11
Ambient conditions		
Ambient temperature		5 ... 55 °C (41 ... 131 °F)
Pollution degree		2
Mechanical specifications		
Degree of protection		IP20
Connection		screw terminals , Cable cross-section 0.2 ... 2.5 mm ²
Material		Polyethylene (PE)
Mass		approx. 200 g

Connection

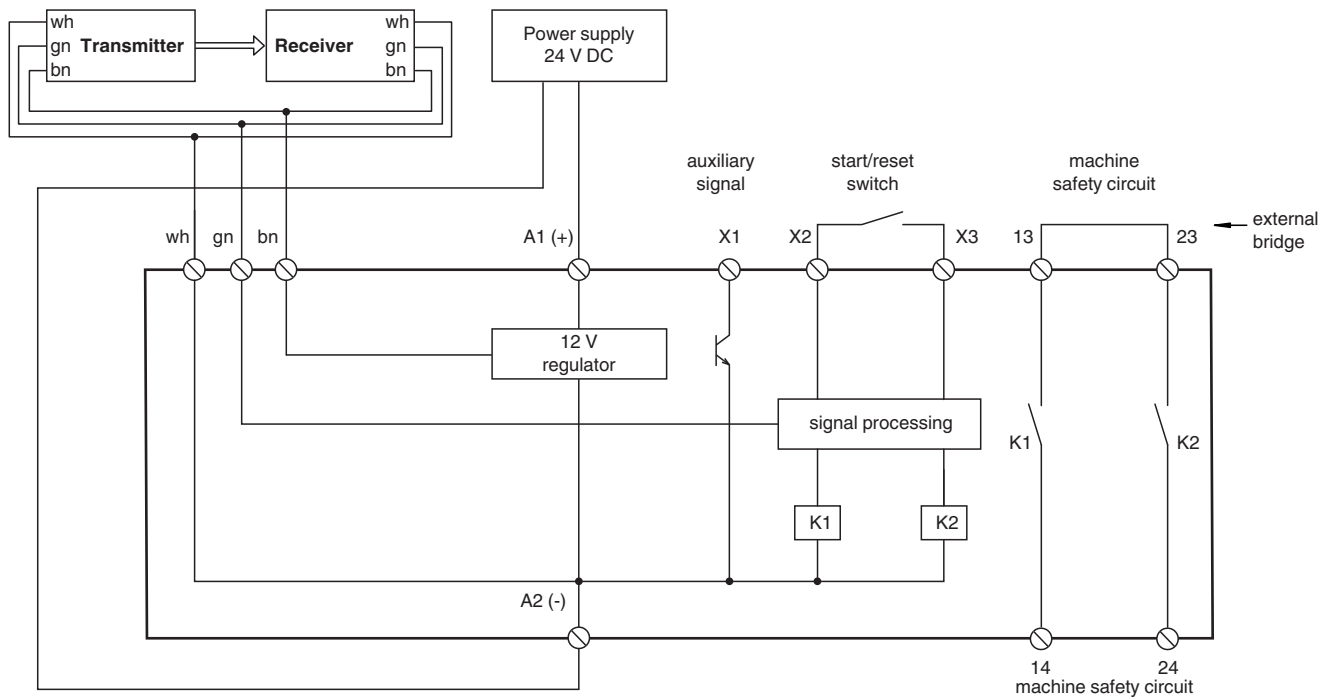

Release date: 2020-10-06 Date of issue: 2020-10-06 Filename: 233900_eng.pdf

Characteristic Curve

Force path diagram

Measurement parameters: T = 23 °C, mounting position B as per EN 1760-2, measuring location C (EN 1760-2), v = 100 mm/s up to A, v = 10 mm/s from A.

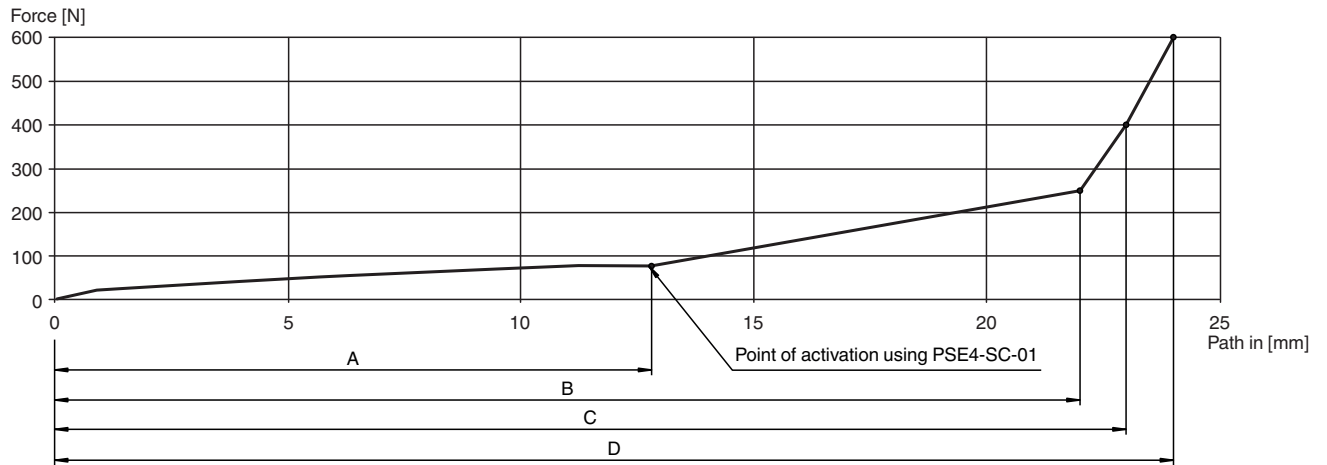

Force path diagram representing the deformation of the sensor strip under force

Deformation under force with control unit PSE4-SC-01			
		Deformation [mm]	Force [N]
A	Resistance	12.8	80
B		22.0	250
C		23.0	400
D		24.0	600

Notes

The modular PSE system comprises the following components:

PSE4-SL safety thru-beam sensors:

The plug electronics are fully encapsulated in the housing to achieve a high level of resistance to environmental influences such as water, dust, and moisture. Degree of protection IP68 is achieved.

Rubber profiles PSE4-RUB and PSE4-ROI:

The rubber profile is designed as a double-chamber profile. The emitter and receiver are inserted in the round hollow chamber at the top. When the profile is actuated, the optical channel is interrupted and the enable circuits on the control unit open. When actuated near the end, the emitter and/or receiver dip into the lower chamber. This ensures that the beam of light is broken. However, the forces required are high, meaning the end areas are inactive areas in line with EN 1760-2.

PSE safety control units:

Controller for the emitter/receiver system.

PSE4-ALU aluminum rails:

The aluminum rails are available in various lengths and can be used as an option.

Functional Principle

The emitter transmits pulses of infrared light, which are detected by the receiver. When the emitter light is detected, the receiver turns off the emitter via a control input. The "luminous flux" stops. The receiver also detects this status and the emitter is then switched on again after a specified time. This coupling produces a dynamic signal that is conveyed, in principle, to a charge pump. The pump's charge state is analyzed in the evaluation.

Any errors in the emitter/receiver system affect the optical or electrical signal, which results in the absence of a dynamic signal.

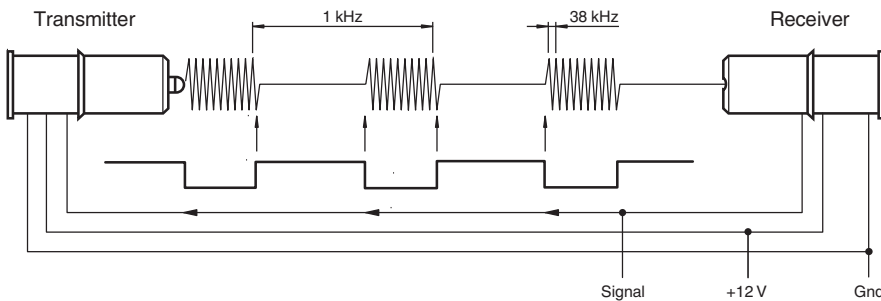

Note:

Safety edges must be fully installed to comply with the EC-Type Examination Certificate for the PSE4 series.

Possible combinations

	PSE4-ALU-*	PSE4-ALU-3009-*	PSE4-ROI-*	PSE4-RUB-*	PSE4-RUB-30EPDM58-*	PSE2-SC-*	PSE4-SC-*	PSE4-SL-*
PSE4-ALU-*			X	X	-	X	X	X
PSE4-ALU-3009-*			-	-	X	X	X	X
PSE4-ROI-*	X	-				X	X	X
PSE4-RUB-*	X	-				X	X	X
PSE4-RUB-30EPDM58-*	-	X				X	X	X
PSE2-SC-*	X	X	X	X	X			X
PSE4-SC-*	X	X	X	X	X			X
PSE4-SL-*	X	X	X	X	X	X	X	

Mounting

Mounting or replacing the sensors

Release date: 2020-10-06 Date of issue: 2020-10-06 Filename: 233900_eng.pdf

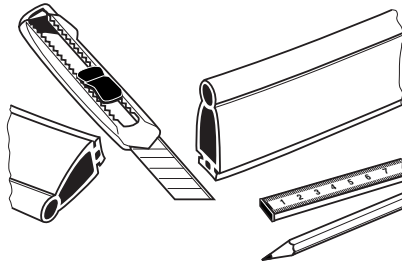

Sensor strip PSE4-RUB-XX or PSE4-ROI-XX and accompanying aluminum mounting strip
Cut PSE4-ALU-XX to the required length.

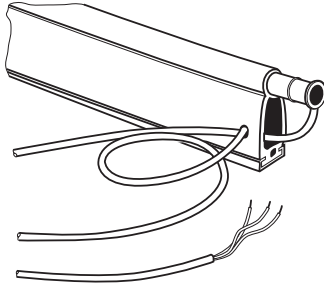

Slide the emitter and receiver into the upper chamber.
Guide the emitter cable through the lower chamber to the receiver side.

Accessories

Other suitable accessories can be found at www.pepperl-fuchs.com

Function

In its entirety, the PSE4 safety edge system consists of the control interface, sensors, a rubber sensor strip, and an optional aluminum mounting strip.

The system can be used within a temperature range of 5 °C to 55 °C.

The control interface analyzes the signal from the sensors and is designed to be installed in a switch cabinet.

The safety contact of the control interface is released by actuating the safety edge.

The system as a whole can be used in applications up to Cat. 4/PL e as defined in EN ISO 13849-1.