



## Ultrasonic sensor

UC2000-30GM-E6R2-V15-Y234253

- Synchronization options
- Temperature compensation
- Customer-specific configuration
- Programming plug permanently bonded and not removable

Single head system



### Dimensions

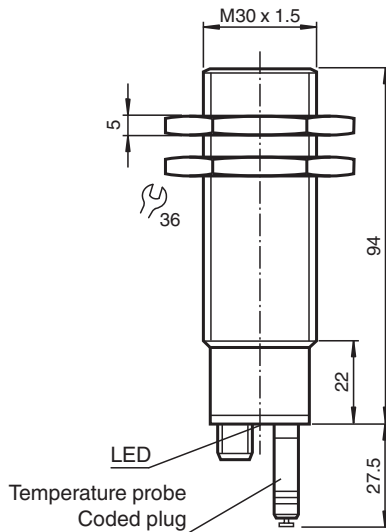

### Technical Data

#### General specifications

Sensing range	80 ... 2000 mm
Adjustment range	120 ... 2000 mm
Dead band	0 ... 80 mm
Standard target plate	100 mm x 100 mm
Transducer frequency	approx. 180 kHz
Response delay	195 ms

#### Indicators/operating means

LED green	solid: Power-on
LED yellow 1	solid: Switching state switch output 1
LED yellow 2	solid: Switching state switch output 2
LED red	flashing: error
Temperature/teach-in connector	Temperature compensation

#### Electrical specifications

Operating voltage	$U_B$	10 ... 30 V DC , ripple 10 % <sub>SS</sub>
-------------------	-------	--

Release date: 2025-06-12 Date of issue: 2025-06-14 Filename: 234253\_eng.pdf

## Technical Data

No-load supply current	$I_0$	$\leq 50$ mA
<b>Interface</b>		
Interface type		RS 232, 9600 Bit/s , no parity, 8 data bits, 1 stop bit
<b>Input/Output</b>		
Synchronization		bi-directional 0 level: $-U_B \dots +1$ V 1 level: $+4$ V $\dots +U_B$ input impedance: $> 12$ KOhm synchronization pulse: $\geq 100$ $\mu$ s, synchronization interpulse period: $\geq 2$ ms
Synchronization frequency		
Common mode operation		max. 30 Hz
Multiplex operation		$\leq 30$ Hz / n , n = number of sensors , $n \leq 5$
<b>Output</b>		
Output type		2 switch outputs PNP, NO
Rated operating current	$I_e$	200 mA , short-circuit/overload protected
Voltage drop	$U_d$	$\leq 2.5$ V
Repeat accuracy		$\leq 0.1$ % of full-scale value
Switching frequency	f	$\leq 2.5$ Hz
Range hysteresis	H	1 % of the set operating distance
Temperature influence		$\leq 2$ % from full-scale value (with temperature compensation)
<b>Compliance with standards and directives</b>		
Standard conformity		
Standards		EN IEC 60947-5-2:2020 IEC 60947-5-2:2019
<b>Approvals and certificates</b>		
UL approval		cULus Listed, General Purpose
CCC approval		CCC approval / marking not required for products rated $\leq 36$ V
<b>Ambient conditions</b>		
Ambient temperature		-25 ... 70 °C (-13 ... 158 °F)
Storage temperature		-40 ... 85 °C (-40 ... 185 °F)
<b>Mechanical specifications</b>		
Connection type		Connector plug M12 x 1 , 5-pin
Degree of protection		IP65
<b>Material</b>		
Housing		stainless steel (1.4305 / AISI 303) PBT plastic parts
Transducer		epoxy resin/hollow glass sphere mixture; polyurethane foam
Mass		140 g
<b>Dimensions</b>		
Length		94 mm
Diameter		30 mm
<b>Factory settings</b>		
Output 1		A1: 1500 mm , NO contact
Output 2		A2 : 500 mm , NO contact

## Connection Assignment

Standard symbol/Connection:  
(version E6, pnp)

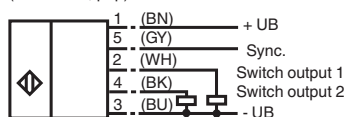

Core colors in accordance with EN 60947-5-2.

# Connection Assignment

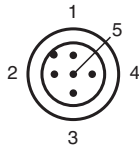

# Characteristic Curve

## Characteristic response curve

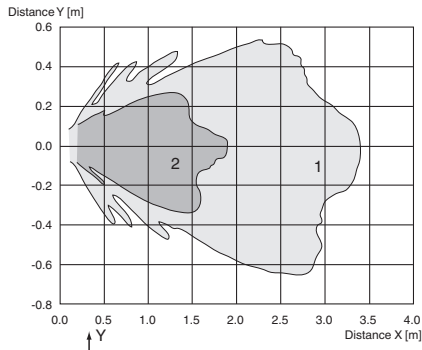

Curve 1: flat surface 100 mm x 100 mm  
Curve 2: round bar, Ø 25 mm

## Switch point mode

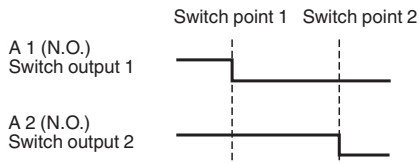

Release date: 2025-06-12 Date of issue: 2025-06-14 Filename: 234253\_eng.pdf

**Additional Information**

**Description of the sensor functions**

**Synchronization**

This sensor features a synchronization input for the possible suppression of ultrasonic mutual interference. If this input is not connected, the sensor will operate using internally generated clock pulses. It can be synchronized by applying an external square wave. The synchronization pulse falling edge triggers each transmission of a single ultrasonic pulse. If the synchronization signal remains low for  $\geq 1$  second, the sensor will revert to non-synchronized mode. Non-synchronized mode can also be activated by opening the signal connection to the synchronization input. (See note below)

If the synchronization input goes to a high level for  $> 1$  second, the sensor will switch to standby mode, indicated by green LED. In this mode the outputs will remain in the last valid output state.

The synchronization function cannot be activated during programming mode and vice versa.

**The following synchronization modes are possible:**

1. Two to five sensors can be synchronized together by interconnecting their respective synchronization inputs. In this case each sensor alternately transmits ultrasonic pulses in a self multiplexing mode. No two sensors will transmit pulses at the same time.
2. Multiple sensors can be controlled by the same external synchronization signal. In this mode the sensors are triggered in parallel and are synchronized by a common external synchronization pulse.
3. A separate synchronization pulse can be sent to each individual sensor. In this mode the sensors operate in external multiplex mode.
4. A high level on the synchronization input disables the sensor.

Sensor response times will increase proportionally to the number of sensors that are in the synchronization string. This is a result of the multiplexing of the ultrasonic transmit and receive signal and the resulting increase in the measurement cycle time.

**Note:**

If the option for synchronization is not used, the synchronization input has to be connected to ground (0V) or the sensor has to be operated via a V1 cordset (4-pin).

**LED Displays**

Displays in dependence on operating mode	Dual LED green	LED red	LED yellow A1	LED yellow A2
Normal mode				
temperature compensated	on	off	switch state A1	switch state A2
Standby	flashes	off	previous state	previous state

LED ON indicates closed switch output.

**LED-Window**

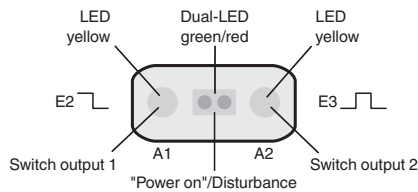

**Installation Conditions**

If the sensor is installed in places where the operating temperature can fall below 0 °C, the BF30, BF30-F or BF 5-30 fixing clamp must be used.

**Commissioning**

**Attention**

The programming plug is permanently bonded to the sensor. It may not be solved by violence. Damaging the sensor would be the result.

Release date: 2025-06-12 Date of issue: 2025-06-14 Filename: 234253\_eng.pdf