



AS-Interface analog module VBA-4A-G11-I/U-F

- Addressing jack
- Degree of protection IP68 / IP69K
- Function display for bus, external auxiliary voltage and outputs
- Supply for outputs from AS-Interface or from bulk power
- Accuracy $\pm 0.15\%$
- Current or voltage output
- Integrated shielding
- Channel-specific output monitoring
- Communication monitoring

G11 analog module, 4 analog outputs



Function

The analog module VBA-4A-G11-I/U-F has four analog outputs. They can be configured either as current outputs (0 mA ... 20 mA) or voltage outputs (0 V ... 10 V). Automatic output detection allows outputs to operate as a current or voltage output, depending on the existing load. The outputs are configured as current outputs on delivery from the factory.

Power is supplied to the outputs through the yellow AS-Interface cable or auxiliary power, depending on the position of the DIP switch. Analog value conversion and data transfer are provided asynchronously according to AS-Interface profile 7.3. The rise time of the analog signals is approx. 2 ms.

If a current output has the analog value "0", lead breakages are not monitored on the respective channel. In this case, peripheral faults are not signaled when there is no active connection to an actuator. If the internal "watchdog" monitoring function is enabled, the output signals are reset to zero if communication with the AS-Interface fails.

The G11 module with IP68/IP69K protection is particularly suitable for demanding field applications. The connection to the actuators is established via M12 connectors. The module can be presaddressed by connecting it to the handheld programming unit VBP-HH1 via the addressing socket. The connection to the AS-Interface transfer line is established using the AS-Interface flat cable.

Note:

A lead breakage at a current output, an output value outside the value range or an overload of the actuator supply is transmitted to the AS-Interface master via the 'peripheral fault' function. Communication via the AS-Interface continues.

Dimensions

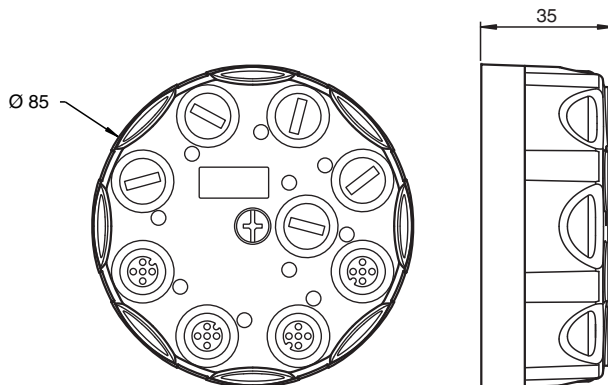

Technical Data

General specifications

Node type	Standard node
AS-Interface specification	V3.0
Required gateway specification	$\geq V2.1$
Profile	S-7.3.6
IO code	7

Release date: 2023-03-28 Date of issue: 2023-03-28 Filename: 237500_eng.pdf

Technical Data

ID code		3
ID1 code		F
ID2 code		6
UL File Number		E223772
Indicators/operating means		
LED AS-i/FAULT		Status display; multi-colour LED Green: normal operation Red: communication fault Flashing yellow/red: address 0 Flashing green/red: peripheral fault
LED ANALOG		Status of output signal; yellow LED Yellow: Output value within range Yellow flashing: lead breakage (on current output) or output value out of range
LED AUX		ext. auxiliary voltage U_{AUX} ; dual LED green/red green: voltage OK red: reverse voltage
LED INT/EXT		status display output supply; LED green green: output supply from AS-Interface off: output supply from auxiliary voltage
Electrical specifications		
Auxiliary voltage (output)	U_{AUX}	24 V DC \pm 15 % PELV
Rated operating voltage	U_e	26.5 ... 31.6 V from AS-Interface
Rated operating current	I_e	\leq 75 mA (without outputs) / max. 200 mA
Protection class		III
Surge protection		U_{AUX} , U_{in} : Over voltage category III, safe isolated power supplies (PELV)
Output		
Number/Type		4 analog outputs Current: 0 ... 20 mA Voltage: 0 ... 10 V
Supply		from AS-Interface (switch position INT, default settings) or auxiliary voltage U_{EXT} (switch position EXT)
Load		voltage output: min. 1 k Ω current output: max. 600 Ω
Current loading capacity		\leq 120 mA (signal current + actuator supply) from AS-Interface; overload and short-circuit protected \leq 700 mA (signal current + actuator supply) from external bulk power supply U_{AUX} , overload and short-circuit protected
Resolution		Voltage output: 3 mV Current output: 6 μ A
Accuracy		0.15 % of full-scale value
Temperature influence		1 μ A/K or 0,3 mV/K
Short-circuit current		voltage output: max. 22 mA
Directive conformity		
Electromagnetic compatibility		
Directive 2014/30/EU		EN 62026-2:2013
Standard conformity		
Degree of protection		EN 60529:2000
Fieldbus standard		EN 62026-2:2013
Emitted interference		EN 61000-6-4:2007
AS-Interface		EN 62026-2:2013
Noise immunity		EN 61000-6-2:2005, EN 61326-1:2006, EN 62026-2:2013
Ambient conditions		
Ambient temperature		-25 ... 60 °C (-13 ... 140 °F)
Storage temperature		-25 ... 85 °C (-13 ... 185 °F)
Relative humidity		85 % , noncondensing
Climatic conditions		For indoor use only
Altitude		\leq 2000 m above MSL
Pollution degree		3
Mechanical specifications		
Degree of protection		IP68 / IP69K

Technical Data

Connection	AS-Interface/U _{AUX} : cable piercing method, flat cable yellow/flat cable black Outputs: M12 round connector
Material	
Housing	PBT PC
Mounting screw	Stainless steel 1.4305 / AISI 303
Mass	200 g
Tightening torque, housing screws	1.8 Nm
Tightening torque, cable gland	0.4 Nm
Mounting	Mounting plate

Connection

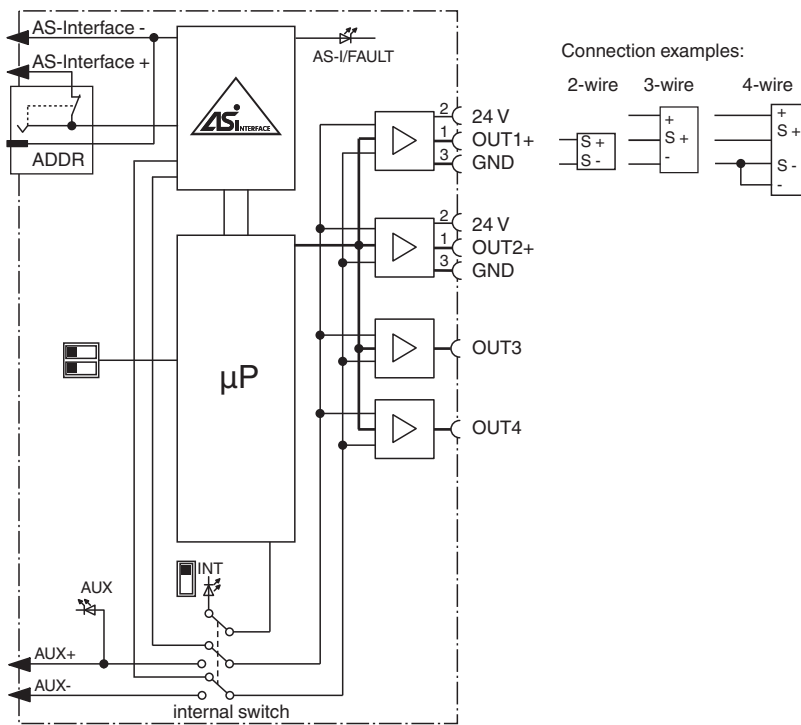

Connection

Do not connect inputs and outputs, which are supplied via the module from AS-interface or via auxiliary power, with power supply and signal circuits with external potentials.

Assembly

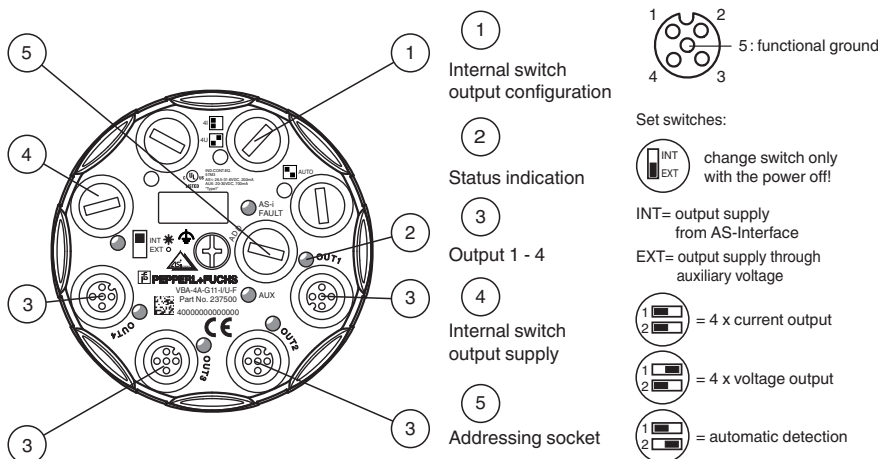

Release date: 2023-03-28 Date of issue: 2023-03-28 Filename: 237500_eng.pdf

Mounting

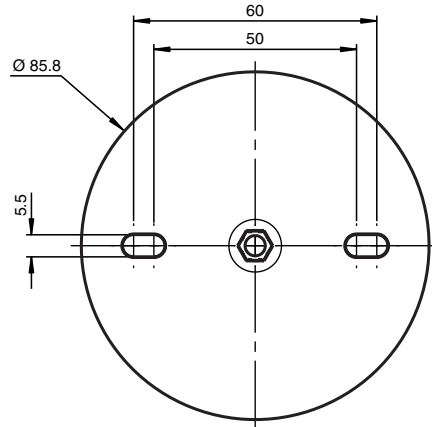

Screw the device onto a level mounting surface using two M4 attachment screws. The functional earth of the M12 round connectors is connected with the metal insert in the base via the tightened central screw. This metal insert can be connected to functional earth via the mounting screws to improve the EMC. The mounting screws are not included. Screw a blind plug onto spare connections to ensure the protection category.

Programming

Data bits

(function via AS-Interface)



The transfer of the data value is based on AS-Interface Profile 7.3.

Parameter bits

(programmable via AS-Interface)

Parameter bit	Function
P0	Watchdog P0=0 watchdog inactive P0=1 watchdog active, default
P1	Output mode P2=0 4 x voltage output P1=1 4 x current output, default
P2	Indication of peripheral fault P2=0 peripheral fault is not reported P2=1 peripheral fault is reported, default
P3	Automatic mode P3=1 manual setting of output mode, default P3=0 automatic load detection, mixed mode possible

Accessories

	VAZ-V1-B3	Blind plug for M12 sockets
	VBP-HH1-V3.0-KIT	AS-Interface Handheld with accessory
	VAZ-PK-1,5M-V1-G	Adapter cable module/hand-held programming device