



## Print mark contrast sensor

### DK12-11-IO/A/92/136



- IO-Link interface for service and process data
- Diffuse mode sensor for recording any print mark
- TEACH-IN, static and dynamic
- 40 µs response time, suitable for extremely rapid scanning processes
- 3 emitter colors: green, red and blue

Print mark contrast sensor with IO-Link interface, 11 mm detection range, RGB light perpendicular to the longitudinal direction of the housing, light/dark on, 2 push-pull outputs, M12 plug



### Function

The contrast sensor DK12 with an IO-Link interface makes continuous communication with the diagnosis system and the parameter assignment up to the sensor level available for the first time. That way it is ensured that the intelligence which is already integrated in each DK12-contrast sensor, is harnessed to the full. This will offer a number of special advantages during service (remedial action, maintenance und device exchange), commissioning (cloning, identification, configuration and localization) or during operation (change of job, continuous parameter monitoring und online diagnosis).

### Dimensions

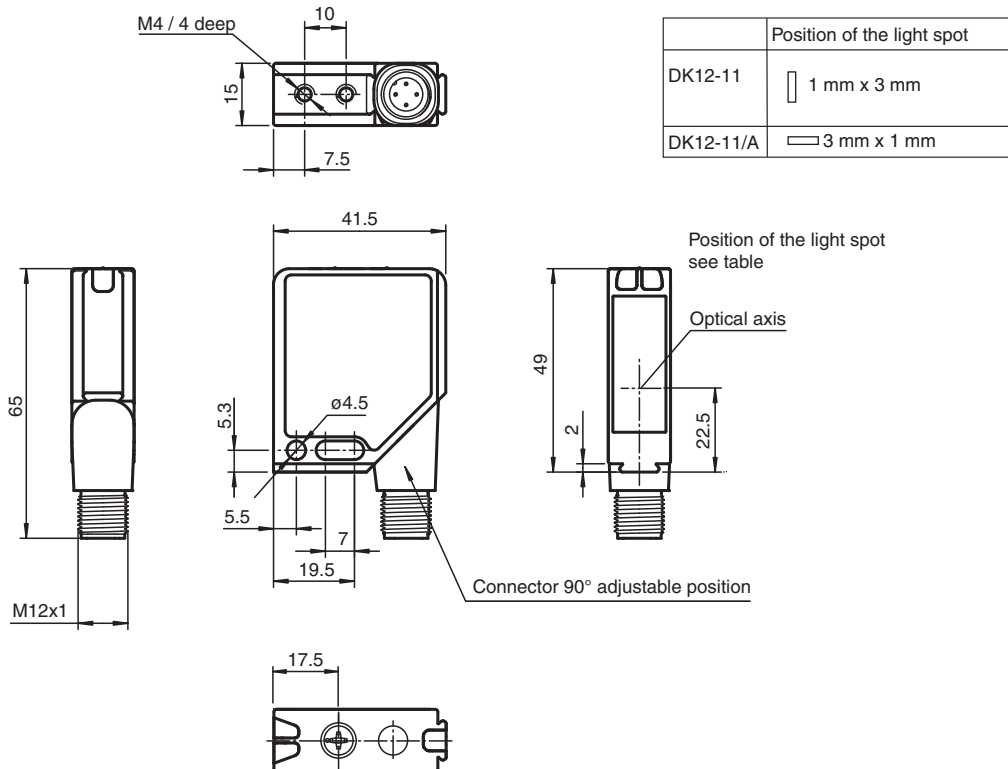

## Technical Data

General specifications		
Sensor range		11 mm ± 2 mm
Light source		3 LEDs (R,G,B)
Light type		Visible green/red/blue, modulated light
Light spot representation		3 mm x 1 mm , light spot perpendicular to housing
Angle deviation		max. ± 3°
Teach-In		static and dynamic Teach-In
Indicators/operating means		
Operation indicator		LED green, statically lit Power on , Undervoltage indicator: Green LED, pulsing (approx. 0.8 Hz) , short-circuit : LED green flashing (approx. 4 Hz) , IO link communication: green LED goes out briefly (1 Hz)
Function indicator		2 LEDs yellow, light up in case of detection
Teach-In indicator		Teach-In mark: LED green/yellow equiphase flashing; 2,5 Hz . Teach-In background: LED green/yellow non equiphase flashing; 2,5 Hz . Teach-In dynamic: LED green/yellow equiphase flashing; 1.0 Hz . Teach Error:LED green/yellow non equiphase flashing; 8.0 Hz .
Control elements		Teach-In rotary switch for Switching operation, Teach-In mark, Teach-In background and dynamic Teach-In
Electrical specifications		
Operating voltage	U <sub>B</sub>	10 ... 30 V DC / when operating in IO-Link mode: 18 ... 30 V
Ripple		10 %
No-load supply current	I <sub>0</sub>	≤ 60 mA at 24 V supply voltage
Interface		
Interface type		IO-Link
Protocol		IO-Link V1.0
Mode		COM2 (38.4 kBit/s)
Output		
Switching type		light/dark on
Signal output		2 push-pull (4 in 1) outputs, complementary, short-circuit proof, reverse polarity protected
Switching voltage		max. 30 V DC
Switching current		max. 100 mA
Switching frequency	f	12.5 kHz
Response time		40 µs
Conformity		
Product standard		EN 60947-5-2
Approvals and certificates		
Protection class		II, rated voltage ≤ 250 V AC with pollution degree 1-2 according to IEC 60664-1
UL approval		cULus Listed , Class 2 power source
CCC approval		CCC approval / marking not required for products rated ≤36 V
Ambient conditions		
Ambient temperature		-20 ... 60 °C (-4 ... 140 °F)
Storage temperature		-40 ... 75 °C (-40 ... 167 °F)
Mechanical specifications		
Housing width		41.5 mm
Housing height		49 mm
Housing depth		15 mm
Degree of protection		IP67
Connection		4-pin, M12 metal connector , can be rotated 90°
Material		
Housing		Frame: nickel plated, die cast zinc, Laterals: glass-fiber reinforced plastic PC
Optical face		Plastic pane
Mass		60 g

**Connection Assignment**

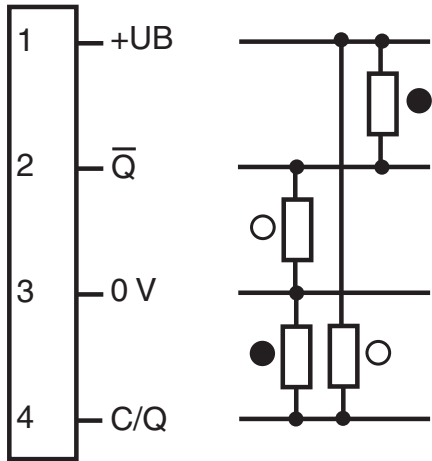

**Interface**

**IO-Link**

IO-Link is a standard for uniform linking of communications-capable sensors and switching devices to the control level with an economical point-to-point connection. IO-Link provides a bidirectional point-to-point connection between I/O modules and field device that combines serial communication in half duplex mode for transferring process data, parameterization, diagnostic evaluation, and power supply. Communication is based on a master-slave structure in which the master controls the interface access to the slave (device) cyclically.

- = Background
- = Mark

**Connection Assignment**

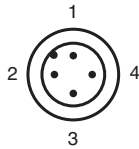

Wire colors in accordance with EN 60947-5-2

- |   |  |    |         |
|---|--|----|---------|
| 1 |  | BN | (brown) |
| 2 |  | WH | (white) |
| 3 |  | BU | (blue)  |
| 4 |  | BK | (black) |

**Assembly**

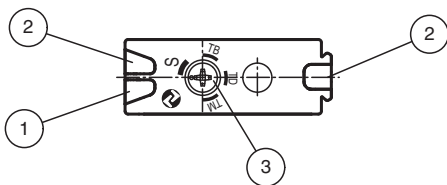

1	Operating display green
2	Switch state yellow
3	Teach-In switch

Release date: 2023-04-04 Date of issue: 2023-04-04 Filename: 244277\_eng.pdf

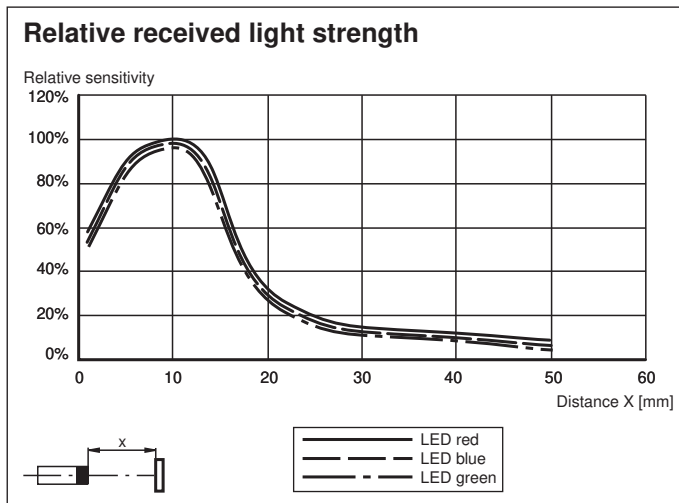

## Interface

### IO-Link Function

The IO-Link operating mode is indicated by the green LED indicator with a short interruption ( $f = 1 \text{ Hz}$ ). IO-Link communication simultaneously provides process data (measurement data from the sensor) and access to service data.

The service data contains the following information:

#### Identification

- Manufacturer information
- Product ID
- User-specific ID

#### Device parameters

- Teach-in parameters
- Operating parameters
- Configuration parameters
- Device commands

#### Diagnostic messages and warnings

## Parameterization

For parameterization and diagnosis, the sensor can be addressed via the integrated IO-Link interface. This interface transmits process data in a cyclic manner, and diagnosis data acyclically.

For this, connect the sensor to an IO-Link primary device and connect the relevant primary device port to the IO-Link device. When communication is established successfully, the green operation display LED flashes briefly every 1 s. The sensor can then be configured or diagnosed by the overlying application and send its process data.

The sensor parameters are device-specific and are described in the standardized IO Device Description file (IODD). The IODD can be read into different engineering tools using IODD support from different system providers. The sensor can then be configured or diagnosed using the relevant tool and a user interface generated from the IODD.

The IODD file, the FDT framework application and the IODD interpreter are available in the corresponding product description under Software on our homepage [www.pepperl-fuchs.com](http://www.pepperl-fuchs.com).

## Teach-In

If the object surfaces are reflective or shiny, tilt the sensor approximately  $10^\circ$  toward the surface of the material.

**Teach-in via rotary switch:** Teach-in via rotary switch is possible in four positions.

- TM position: Teach-in mark
- TB position: Teach-in background
- TD position: Teach-in dynamic
- S position: Switching mode

To change the switch position, a time lock of approximately 2 second must be adhered to in each case. This means that the rotary switch must remain in a new position constantly for 2 second in order for the sensor to accept the required mode. The mode can be identified by the how the flashing function of the signal indicators changes.

**Static teach-in (TM/TB):** The mark or the background can be taught-in in static teach-in mode, either together (in any order) or separately.

Therefore it is not mandatory to always teach-in the mark and the background.

- **TM position:** When the rotary switch remains in the TM position constantly for 2 seconds, the teach-in procedure starts. When mark is taught in, the green and yellow signal indicators flash simultaneously at  $f = 2.5 \text{ Hz}$ .

- **TB position:** When the rotary switch remains in the TB position constantly for 2 seconds, the teach-in procedure starts. When background is taught in, the green and yellow signal indicators flash alternately at  $f = 2.5 \text{ Hz}$ .











#### Teach-in dynamic (TD)

- **TD position:** When the rotary switch remains in the TD position constantly for 2 seconds, the teach-in process starts. Continuous value transfer takes place, and the sensor interprets the first recorded signals as a background after entering "dynamic teach-in" mode. For the duration of "dynamic teach-in" mode, the sensor indicates the greatest deviation from the background as a mark. In "teach-in dynamic" mode, the green and yellow signal indicators flash simultaneously at  $f = 1.0 \text{ Hz}$ . When the rotary switch remains in a new position constantly for 2 seconds, the teach-in dynamic procedure is terminated.

#### Switching mode (S)

- **S position:** The current teach-in mode is terminated. The received signals of all 3 emitter light colors for the mark and background are evaluated.

## Accessories

	<b>PACTware 4.1</b>	FDT Framework
	<b>ICE2-8IOL-G65L-V1D</b>	EtherNet/IP IO-Link master with 8 inputs/outputs
	<b>ICE3-8IOL-G65L-V1D</b>	PROFINET IO IO-Link master with 8 inputs/outputs
	<b>ICE1-8IOL-G30L-V1D</b>	Ethernet IO-Link module with 8 inputs/outputs
	<b>ICE1-8IOL-G60L-V1D</b>	Ethernet IO-Link module with 8 inputs/outputs
	<b>ICE2-8IOL-K45P-RJ45</b>	EtherNet/IP IO-Link master with 8 inputs/outputs, DIN rail, push-in connectors
	<b>ICE2-8IOL-K45S-RJ45</b>	EtherNet/IP IO-Link master with 8 inputs/outputs, DIN rail, screw terminal
	<b>ICE3-8IOL-K45P-RJ45</b>	PROFINET IO IO-Link master with 8 inputs/outputs, DIN rail, push-in terminals
	<b>ICE3-8IOL-K45S-RJ45</b>	PROFINET IO IO-Link master with 8 inputs/outputs, DIN rail, screw terminal
	<b>IO-Link-Master02-USB</b>	IO-Link master, supply via USB port or separate power supply, LED indicators, M12 plug for sensor connection