



AS-Interface Gateway/Safety Monitor

VBG-PB-K30-DMD-S16-EV

- Gateway and safety monitor in one housing
- Connection to PROFIBUS DP
- SafeLink
- Certified up to SIL 3 according to IEC 61508 and EN 62061 and up to PL_e according to EN 13849
- 2 AS-Interface networks
- 2 safe output relays and 2 safe electronic outputs
- Integrated data decoupling
- Diagnostics via RJ45 Ethernet port
- AS-Interface POWER24

Gateway with integrated Safety Monitor



Function

The VBG-PB-K30-DMD-S16-EV is a PROFIBUS gateway with a safety monitor and a double master according to AS-Interface specification 3.0. The gateway is used to connect AS-Interface systems to a higher-level PROFIBUS. It acts as a master for the AS-Interface segment and as a slave for the PROFIBUS. During cyclic and acyclic data exchange, the AS-Interface functions are provided via PROFIBUS - DP V1. During cyclic data exchange the binary data of an AS-Interface segment is transferred. Analog values as well as the complete command set of the new AS-Interface specification are transferred via PROFIBUS using a command interface. The gateway has four inputs and four outputs. The four inputs are used either for extended EDM device monitoring or as start inputs. Two sets of two outputs act as relay outputs and switch output circuits 1 and 2 and, as semiconductor outputs, output circuits 3 and 4. The K30 model is particularly suitable for installation in a control cabinet. Configuration of the device can be performed using switches. Seven LED located on the front panel indicate the current status of the AS-Interface segment. One LED shows the power supply via AUX. A further eight LEDs indicate the status of the inputs and outputs. With the graphical display, the commissioning of the AS-Interface circuits and testing of the connected peripherals can take place completely separately from the commissioning of the higher-level network and the programming. With the 4 switches, all functions can be controlled and visualized on the display. An RJ-45 Ethernet port provides a way of exporting data relating to the gateway, network and operation directly from the gateway for extended local diagnosis purposes. Via the RJ-45 Ethernet diagnostic interface, up to 31 devices can establish a secure cross-communication. The integrated data decoupling allows to operate 2 AS-Interface circuits with just a standard power supply. The device has a card slot for a memory card for the storage of configuration data.

Dimensions

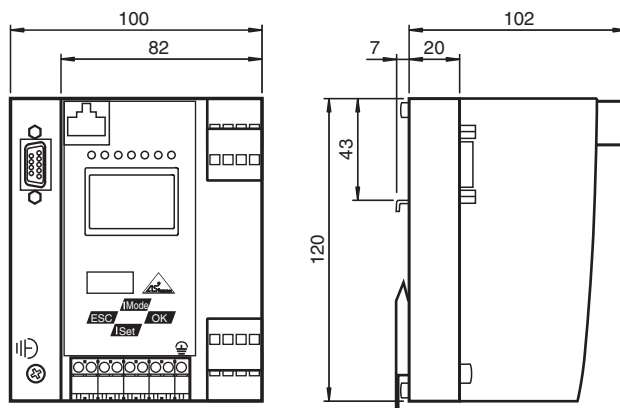

Technical Data

General specifications

AS-Interface specification	V3.0
PLC-Functionality	activateable

Release date: 2022-03-24 Date of issue: 2022-03-24 Filename: 245875_eng.pdf

Technical Data

Duplicate address detection		from AS-Interface slaves
Earth fault detection	EFD	integrated
EMC monitoring		integrated
Diagnostics function		Extended function via display
Data decoupling		integrated
Switch-on delay		< 10 s
Response delay		< 40 ms
UL File Number		E223772 only from low voltage, limited energy source (SELV or PELV) or listed Class 2 source
Functional safety related parameters		
Safety Integrity Level (SIL)		SIL 3
Performance level (PL)		PL e
MTTF _d		200 a
B _{10d}		2 E+7
Indicators/operating means		
Display		Illuminated graphical LC display for addressing and error messages
LED PROFIBUS		PROFIBUS master detected; LED green
LED AS-i ACTIVE		AS-Interface operation normal; LED green
LED CONFIG ERR		configuration error; LED red
LED PRG ENABLE		autom. programming; LED green
LED POWER		voltage ON; LED green
LED PRJ MODE		projecting mode active; LED yellow
LED U AS-i		AS-Interface voltage; LED green
LED AUX		ext. auxiliary voltage U _{AUX} ; LED green
LED EDM/Start		External device monitoring circuit inputs closed, 4x yellow LEDs
LED output circuit		Output circuit closed; 4 x green LEDs
Button		4
Electrical specifications		
Insulation voltage	U _i	≥ 500 V
Rated operating voltage	U _e	30 V DC 20 ... 31.6 V (PELV)
Rated operating current	I _e	300 mA (PELV)
Power supply		max. 4 A per AS-Interface circuit
Interface 1		
Interface type		RS-485
Protocol		PROFIBUS DP V1
Transfer rate		9.6 kBit/s / 12 MBit/s , Automatic baud rate detection
Interface 2		
Interface type		Ethernet: RJ-45 Diagnostic Interface
Interface 3		
Interface type		Chip card slot
Input		
Number/Type		4 EDM/Start inputs: EDM: Inputs for the external device monitoring circuits Start: start inputs: Static switching current 4 mA at 24 V, dynamic 30 mA at 24 V (T=100 μs)
Output		
Safety output		Output circuits 1 and 2: 2 potential-free contacts, max. contact load: 3 A _{DC-13} at 30 V _{DC} , 3 A _{AC-15} at 30 V _{AC} Output circuits 3 and 4: 2 PNP transistor outputs max. contact load: 0.5 A _{DC-13} at 30 V _{DC}
Connection		
PROFIBUS		Sub-D interface

Technical Data

AS-Interface	spring terminals, removable
Directive conformity	
Electromagnetic compatibility	
Directive 2014/30/EU	EN 62026-2:2013 EN 61000-6-2:2005, EN 61000-6-4:2007
Standard conformity	
Electromagnetic compatibility	EN 61000-6-2:2005, EN 61000-6-4:2007
Degree of protection	EN 60529:2000
Fieldbus standard	PROFIBUS according to DIN 19245 Part 3
AS-Interface	EN 62026-2:2013
Shock resistance	EN 61131-2:2004
Standards	IEC 61508:2010 (SIL3) IEC 62061:2005 (SIL3) EN ISO 13849-1:2008 (PL e)
Approvals and certificates	
UL approval	An isolated source with a secondary open circuit voltage of $\leq 30 V_{DC}$ with a 3 A maximum over current protection. Over current protection is not required when a Class 2 source is employed. UL mark does not provide UL certification for any functional safety rating or aspects of the device.
CCC approval	CCC approval / marking not required for products rated $\leq 36 V$
Ambient conditions	
Ambient temperature	0 ... 55 °C (32 ... 131 °F)
Storage temperature	-25 ... 85 °C (-13 ... 185 °F)
Mechanical specifications	
Degree of protection	IP20
Material	
Housing	Stainless steel
Mass	800 g
Construction type	Low profile housing , Stainless steel

Connection

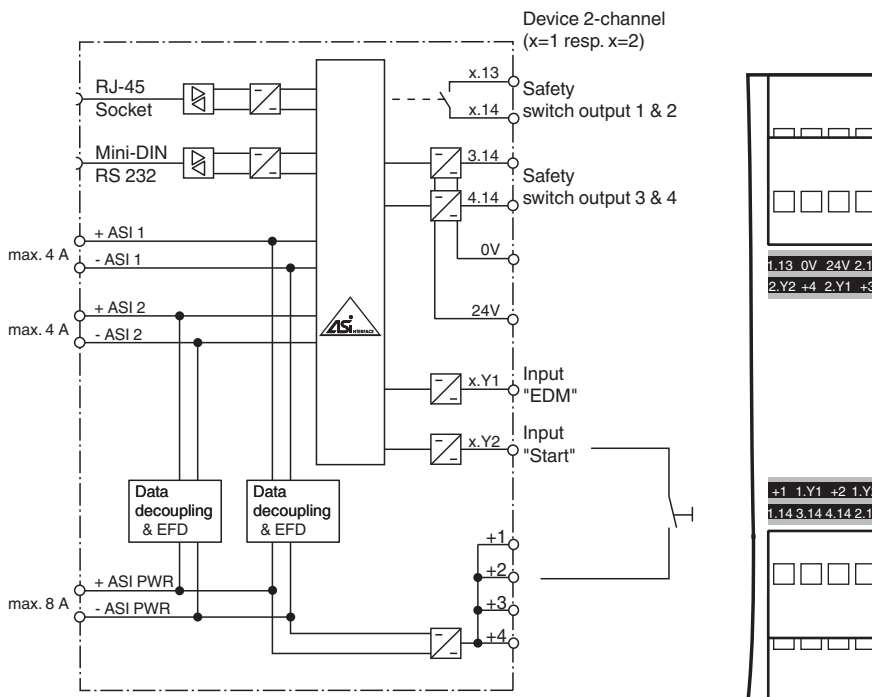

Release date: 2022-03-24 Date of issue: 2022-03-24 Filename: 245875_eng.pdf

Assembly

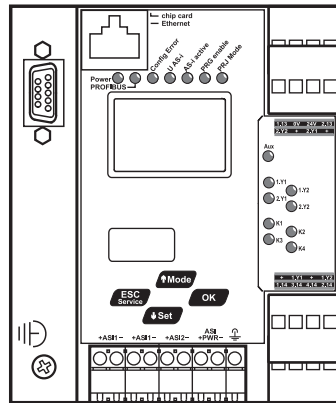

Installation

Supply of 2 AS-Interface circuits and optional supply of several gateways with one power supply unit. For short cable lengths, a standard 24 V power supply can be used.

Operation

In an AS-Interface network only one device can be operated earth fault detection. If there are many devices in an AS-Interface network, this can lead to the earth fault monitoring response threshold becoming less sensitive.

Accessories

	<p>VAZ-SW-SIMON+</p>	<p>Software for configuration of K30 Master Monitors/K31 and KE4 Safety Monitors</p>
--	-----------------------------	--