



## Relay Module

### KFD0-RO-2

- 2-channel signal conditioner
- 24 V DC supply (loop powered)
- Logic input 15 V DC ... 30 V DC, non-polarized
- Relay contact output
- Up to SIL 3 acc. to IEC/EN 61508

# CE SIL3

## Function

This signal conditioner provides the galvanic isolation between field circuits and control circuits. The device switches circuits on the field side. Typical applications for the use of the device are remote reset, fire alarm testing or remote calibration of strain gauges. The outputs are galvanically isolated to the inputs. The inputs are not polarized and share a common reference potential. Each input of the device is protected by a fuse and an electronic current limiting.

## Connection

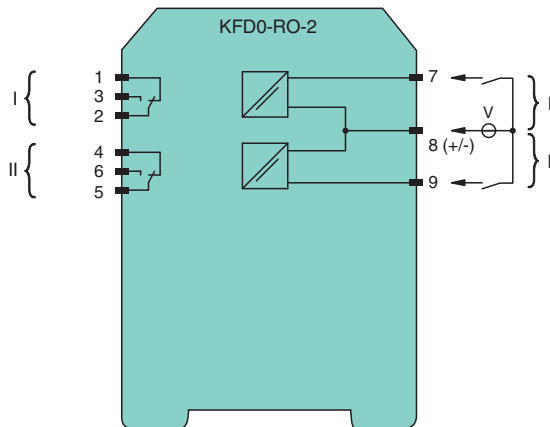

## Technical Data

### General specifications

Signal type Digital Output

### Functional safety related parameters

Safety Integrity Level (SIL) SIL 3

### Supply

Rated voltage  $U_r$  15 ... 30 V DC , loop powered

Power dissipation 0.8 W

### Input

Connection side control side

Connection terminals 7, 8, 9

Input voltage 15 ... 30 V DC

## Technical Data

Input current	≤ 21 mA per channel
<b>Output</b>	
Connection side	field side
Connection	terminals 1, 2, 3; 4, 5, 6
Contact loading	230 V AC/4 A/cos φ > 0.7; 30 V DC/4 A resistive load
Energized/De-energized delay	approx. 10 ms / approx. 5 ms
Mechanical life	5 x 10 <sup>6</sup> switching cycles
Electrical life	10 <sup>5</sup> switching cycles , at maximum load
<b>Transfer characteristics</b>	
Switching frequency	< 10 Hz
<b>Galvanic isolation</b>	
Input/Output	reinforced insulation according to IEC/EN 61010-1, rated insulation voltage 300 V <sub>eff</sub>
Output/Output	basic insulation according to IEC/EN 61010-1, rated insulation voltage 300 V <sub>eff</sub>
<b>Indicators/settings</b>	
Display elements	LEDs
Labeling	space for labeling at the front
<b>Directive conformity</b>	
Electromagnetic compatibility	
Directive 2014/30/EU	EN 61326-1:2013 (industrial locations)
Low voltage	
Directive 2014/35/EU	EN 61010-1:2010
<b>Conformity</b>	
Electromagnetic compatibility	NE 21:2006
Degree of protection	IEC 60529:2001
<b>Ambient conditions</b>	
Ambient temperature	-20 ... 65 °C (-4 ... 149 °F)
<b>Mechanical specifications</b>	
Degree of protection	IP20
Connection	screw terminals
Mass	approx. 100 g
Dimensions	20 x 119 x 115 mm (0.8 x 4.7 x 4.5 inch) (W x H x D) , housing type B2
Mounting	on 35 mm DIN mounting rail acc. to EN 60715:2001
<b>General information</b>	
Supplementary information	Observe the certificates, declarations of conformity, instruction manuals, and manuals where applicable. For information see <a href="http://www.pepperl-fuchs.com">www.pepperl-fuchs.com</a> .

**Assembly**

Front view

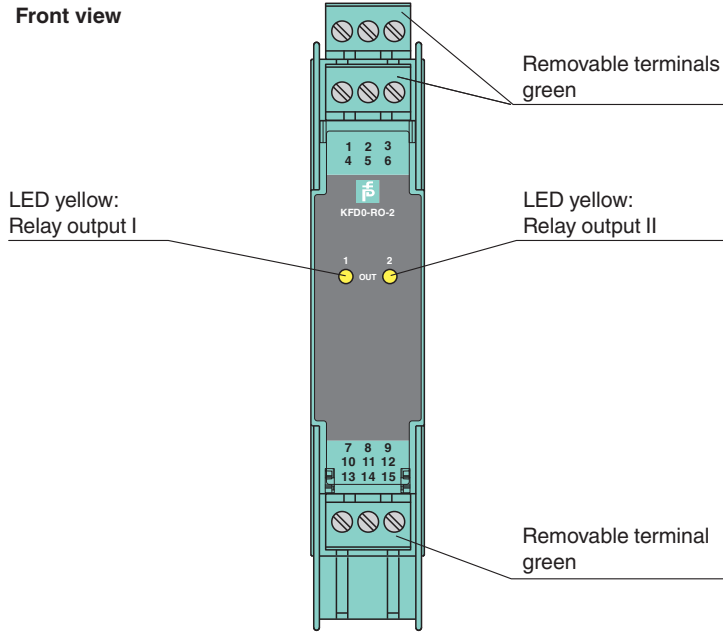

Release date: 2024-08-13 Date of issue: 2024-08-13 Filename: 247196\_eng.pdf

**Characteristic Curve**

**Maximum switching power of output contacts**

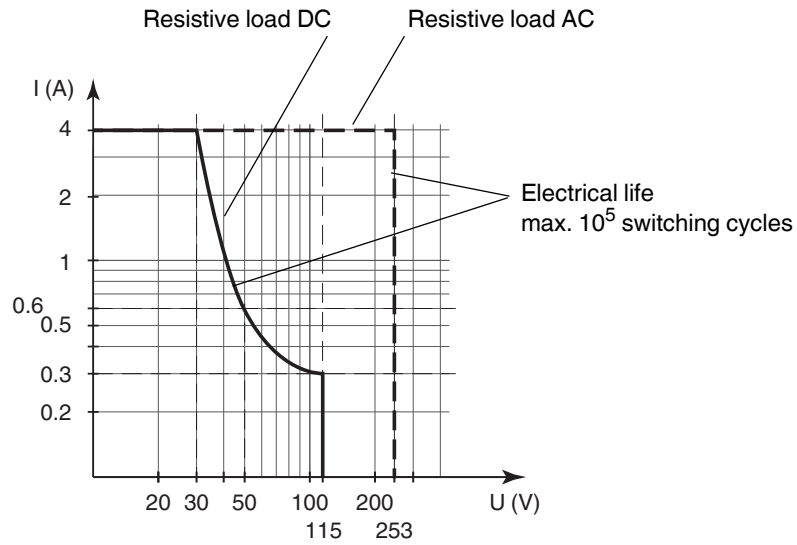

The maximum number of switching cycles is depending on the electrical load and may be higher when reduced currents and voltages are applied.

Release date: 2024-08-13 Date of issue: 2024-08-13 Filename: 247196\_eng.pdf