



AS-Interface Gateway/Safety Monitor VBG-ENX-K30-DMD-S16-EV

- Gateway and safety monitor in one housing
- Connection to Ethernet Modbus TCP/IP
- SafeLink
- Integrated data decoupling
- Integrated webservice
- Certified up to SIL 3 according to IEC 61508 and EN 62061 and up to PL_e according to EN 13849
- Memory card for configuration data
- 2 AS-Interface networks
- 2 safe output relays and 2 safe electronic outputs
- Integrated switch allows line topology
- DLR technology supports ring topology
- Max. 32 independent safety loops

EtherNet/IP + Modbus TCP Gateway with integrated safety monitor, double master for 2 AS-Interface networks, power supply input with data decoupling



Function

The VBG-ENX-K30-DMD-S16-EV is an Ethernet/IP+Modbus TCP gateway with an integrated safety monitor and a double master according to AS-Interface specification 3.0 with a degree of protection IP20. The gateway has built-in decoupling coils. This allows two AS-Interface circuits to be operated by a single AS-Interface power supply. The device is a gateway with full functionality combined with a safety monitor. The gateway connects an AS-Interface system to a higher-level Ethernet or Modbus protocol. It acts as a master for the AS-Interface segment and as a slave for Ethernet / Modbus. During cyclic data exchange, the digital data of an AS-Interface segment is transferred. Analog values as well as the complete command set of the new AS-Interface specification are transferred via Ethernet / Modbus using a command interface. The gateway has four inputs and four outputs. The four inputs are used either for extended EDM device monitoring or as start inputs. Two sets of two outputs act as relay outputs and switch output circuits 1 and 2 and, as semiconductor outputs, output circuits 3 and 4. The K30 model is particularly suitable for installation in a control cabinet. Configuration of the device can be performed using switches. Seven LED located on the front panel indicate the current status of the AS-Interface segment. One LED shows the power supply via AUX. A further eight LEDs indicate the status of the inputs and outputs. With the graphical display, the commissioning of the AS-Interface circuits and testing of the connected peripherals can take place completely separately from the commissioning of the higher-level network and the programming. With the 4 switches, all functions can be controlled and visualized on the display. The device has a card slot for a memory card for the storage of configuration data. An integrated Switch and 2 RJ-45 sockets allow the design of a line topology without the use of an external Switch. The device level ring protocol DLR increases the reliability of a ring topology at the device level, thus optimizing the machine running times. An integrated webservice allows to administrate the device and The AS-interface network without additional hard and/or software via a browser interface.

Dimensions

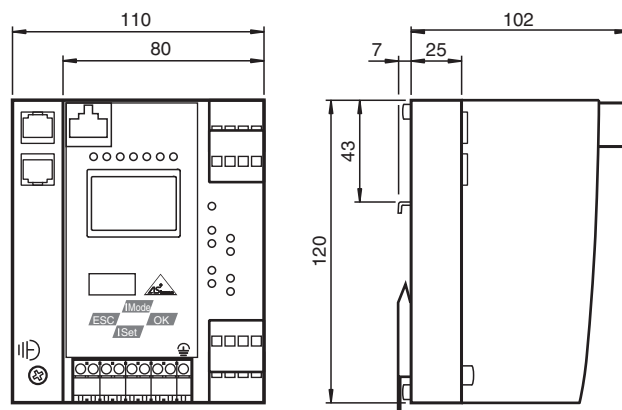

Technical Data

General specifications		
AS-Interface specification		V3.0
PLC-Functionality		activateable
Duplicate address detection		from AS-Interface slaves
Earth fault detection	EFD	integrated
EMC monitoring		integrated
Diagnostics function		Extended function via display
Data decoupling		integrated
Switch-on delay		< 10 s
Response delay		< 40 ms
UL File Number		E223772 only from low voltage, limited energy source (SELV or PELV) or listed Class 2 source
Functional safety related parameters		
Safety Integrity Level (SIL)		SIL 3
Performance level (PL)		PL e
MTTF _d		200 a
B _{10d}		2 E+7
Indicators/operating means		
Display		Illuminated graphical LC display for addressing and error messages
LED ETHERNET		ethernet active; LED green
LED AS-i ACTIVE		AS-Interface operation normal; LED green
LED CONFIG ERR		configuration error; LED red
LED PRG ENABLE		autom. programming; LED green
LED POWER		voltage ON; LED green
LED PRJ MODE		projecting mode active; LED yellow
LED U AS-i		AS-Interface voltage; LED green
LED AUX		ext. auxiliary voltage U _{AUX} ; LED green
LED EDM/Start		External device monitoring circuit inputs closed, 4x yellow LEDs
LED output circuit		Output circuit closed; 4 x green LEDs
Button		4
Switch SET		Selection and setting of a slave address
OK button		Mode selection traditional-graphical/confirmation
Button MODE		Mode selection PRJ-operation/save configuration/cursor
ESC button		Mode selection traditional-graphical/cancel
Electrical specifications		
Insulation voltage	U _i	≥ 500 V
Rated operating voltage	U _e	26.5 ... 31.6 V from AS-Interface; Output K3 and K4 24 V _{DC}
Rated operating current	I _e	≤ 300 mA from AS-Interface
Power supply		max. 4 A per AS-Interface circuit
Interface 1		
Interface type		2 x RJ-45
Protocol		EtherNet/IP + MODBUS TCP/IP acc. to IEEE 802.3 supports device level ring protocol DLR
Transfer rate		10 MBit/s / 100 MBit/s , Automatic baud rate detection
Interface 2		
Interface type		Ethernet: RJ-45 Diagnostic Interface
Transfer rate		10 MBit/s
Interface 3		
Interface type		Chip card slot
Input		
Number/Type		4 EDM/Start inputs: EDM: Inputs for the external device monitoring circuits Start: start inputs: Static switching current 4 mA at 24 V, dynamic 30 mA at 24 V (T=100 μs)

Technical Data

Output	
Safety output	Output circuits 1 and 2: 2 potential-free contacts, max. contact load: 3 A _{DC-13} at 30 V _{DC} , 3 A _{AC-15} at 30 V _{AC} Output circuits 3 and 4: 2 PNP transistor outputs max. contact load: 0.5 A _{DC-13} at 30 V _{DC}
Connection	
Ethernet	RJ-45
AS-Interface	spring terminals, removable
Directive conformity	
Electromagnetic compatibility	
Directive 2014/30/EU	EN 62026-2:2013 EN 61000-6-2:2005, EN 61000-6-4:2007
Machinery Directive	
Directive 2006/42/EC	EN 61508-1:2010 EN/ISO 13849-1:2008 EN 62061:2005
Standard conformity	
Electromagnetic compatibility	
Degree of protection	EN 61000-6-2:2005, EN 61000-6-4:2007
AS-Interface	EN 62026-2:2013
Shock resistance	EN 61131-2:2004
Standards	EN 61000-6-2:2005, EN 61000-6-4:2007 EN 61326-3-1:2008 IEC 61508:2010 and EN 62061:2005 (up to SIL3) EN 13849:2008 (PL e)
Approvals and certificates	
UL approval	An isolated source with a secondary open circuit voltage of ≤ 30 V _{DC} with a 3 A maximum over current protection. Over current protection is not required when a Class 2 source is employed. UL mark does not provide UL certification for any functional safety rating or aspects of the device.
Ambient conditions	
Ambient temperature	0 ... 55 °C (32 ... 131 °F)
Storage temperature	-25 ... 85 °C (-13 ... 185 °F)
Mechanical specifications	
Degree of protection	IP20
Material	
Housing	Stainless steel
Mass	800 g
Construction type	Low profile housing , Stainless steel

Connection

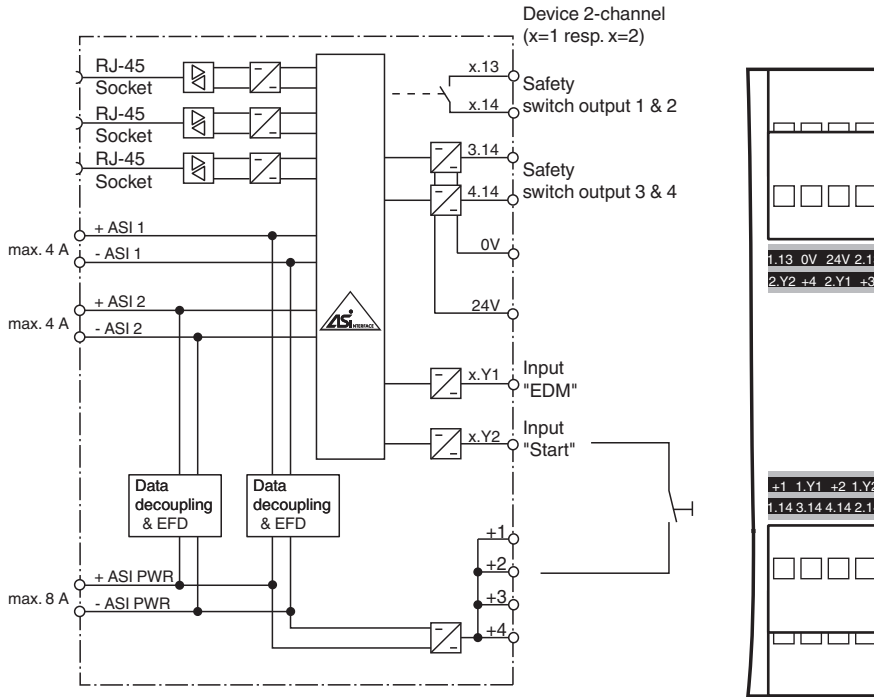

Indication

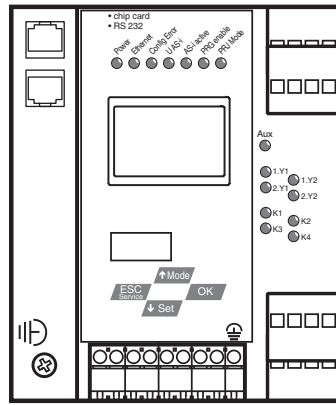

Operation

In an AS-Interface network only one device can be operated earth fault detection. If there are many devices in an AS-Interface network, this can lead to the earth fault monitoring response threshold becoming less sensitive.

Accessories

	<p>VAZ-SW-SIMON+</p>	<p>Software for configuration of K30 Master Monitors/K31 and KE4 Safety Monitors</p>
--	-----------------------------	--

Release date: 2022-03-24 Date of issue: 2022-03-24 Filename: 254539_eng.pdf