

# Accessory DGE DoorScan Relay Module

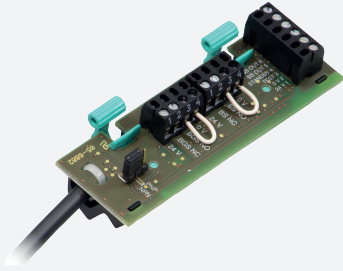

- Sensor module for configurable DoorScan® presence sensor
- Conversion of semiconductor signals to relay output signals
- Tool-free module mounting using snap-in mechanism

Replacement/extension sensor module for installation in the DoorScan® and TopScan sensor profile, multifunction interface module

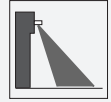

## Dimensions

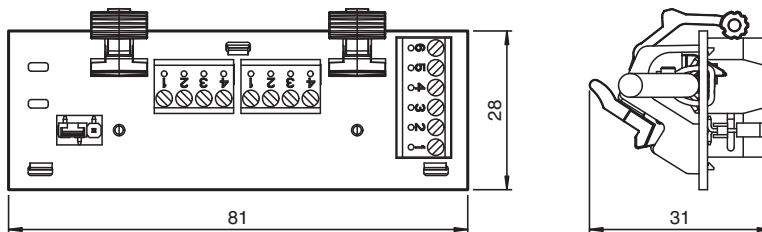

## Technical Data

### Functional safety related parameters

Safety Integrity Level (SIL)	SIL 2
Performance level (PL)	PL d
Category	Cat. 2
MTTF <sub>d</sub>	72 a
B <sub>10d</sub>	2 E+8
B <sub>10</sub>	3 E+6

### Indicators/operating means

Control elements	Jumper for interface PNP / NPN
------------------	--------------------------------

### Electrical specifications

Operating voltage	U <sub>B</sub>	24 V DC ± 20 %
No-load supply current	I <sub>0</sub>	30 mA

### Input

Input type	Test, Standby , Relay supply
------------	------------------------------

### Output

Signal output	Hinge side (BS): Relay, 1 alternator , Opposite hinge side (BGS): Relay, 1 alternator
---------------	---

Release date: 2020-09-09 Date of issue: 2020-10-08 Filename: 254993\_eng.pdf

**Technical Data**

Switching voltage		24 V DC ± 20 %
Switching current		max. 100 mA
Response time		max. 15 ms in addition to switch-on delay for DoorScan®
De-energized delay	t <sub>off</sub>	max. 15 ms
<b>Compliance with standards and directives</b>		
Directive conformity		
Machinery Directive 2006/42/EC		EN 12978:2003+A1:2009 EN ISO 13849-1:2008 + AC:2009 EN 16005:2012 Chapter 4.6.8
EMC Directive 2004/108/EC		EN 61000-6-2:2005 EN 61000-6-3:2007+A1:2011
Standard conformity		
Standards		EN 61508-1:2010 DIN 18650-1:2010 Chapter 5.7.4 BS 7036-1:1996 Chapter 7.3.2 BS 7036-2:1996 Chapter 8.1
<b>Approvals and certificates</b>		
CCC approval		CCC approval / marking not required for products rated ≤36 V
<b>Ambient conditions</b>		
Ambient temperature		-30 ... 60 °C (-22 ... 140 °F)
Relative humidity		25 ... 95 % (noncondensing)
<b>Mechanical specifications</b>		
Degree of protection		IP54 (iwhen mounted)
Connection		plug strip , 6-pin Interface , 4-pin Relay supply
Mass		approx. 30 g

**Connection Assignment**

**Connection Terminal**

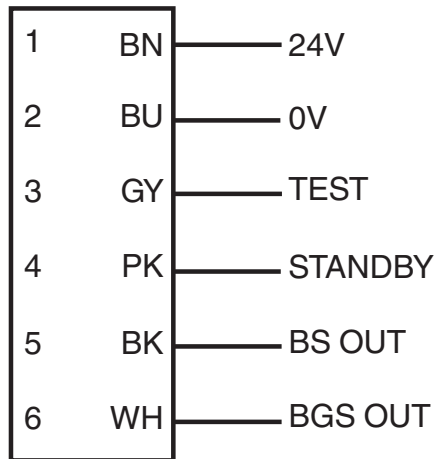

Configuration terminal, door hinge side  
Configuration terminal, hinge opposite side  
(can be used as an output as well)

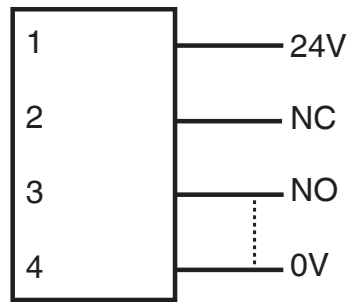

(bridged between 0 V and NO by default)

**Jumper**



Release date: 2020-09-09 Date of issue: 2020-10-08 Filename: 254993\_eng.pdf

**Safety Information**



**Attention!**

The required Performance Level is achieved only if a NO contact is used to signal the state "No object in protection field."

In particular:

- For synchronized DoorScan outputs, NO contacts must be evaluated on the relay module.
- For antivallent DoorScan outputs, the NO contact for the door hinge side and the NC contact for the hinge opposite side must be evaluated on the relay module.

**Mounting**

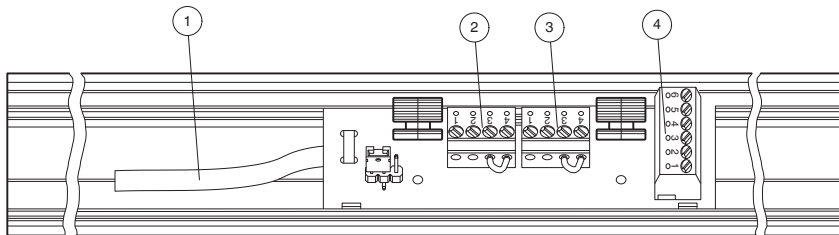
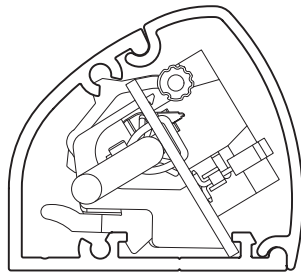

- ① Interface connection cable
- ② Configuration terminals, hinge opposite side
- ③ Configuration terminals, door hinge side
- ④ Terminal for door transition cable to drive

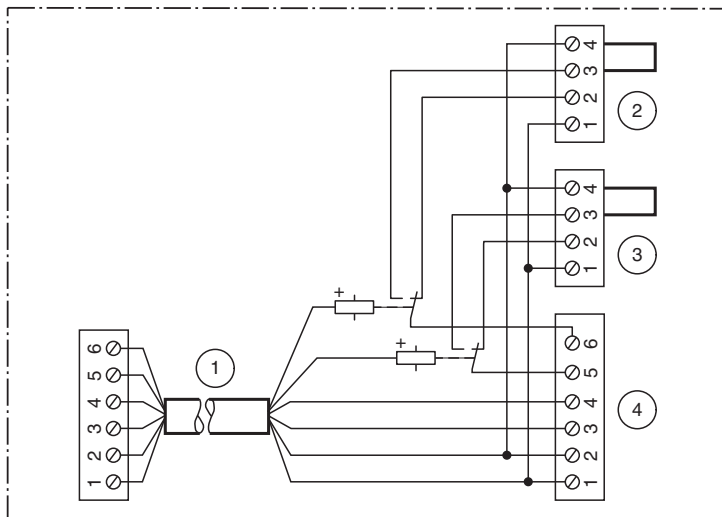

**Bridging—Circuitry of configuration terminals**

		24 V	0 V
②	BGS	NO 1 - 3	3 - 4*
		NC 1 - 2	2 - 4

Release date: 2020-09-09 Date of issue: 2020-10-08 Filename: 254993\_eng.pdf

## Accessory DGE

## DoorScan Relay Module

3	BS	NO	1 - 3	3 - 4*
		NC	1 - 2	2 - 4

\* = Default setting