



# Optical reading head

## PGV100-F200A-B6-V15B

- Mechanically rugged: no wearing parts, long operating life, maintenance-free
- PROFIBUS interface
- Non-contact positioning on Data Matrix code tape
- Noncontact positioning with Data Matrix TAGs
- Reading of Data Matrix control codes
- White-blue light

Read head for incident light positioning system



### Dimensions

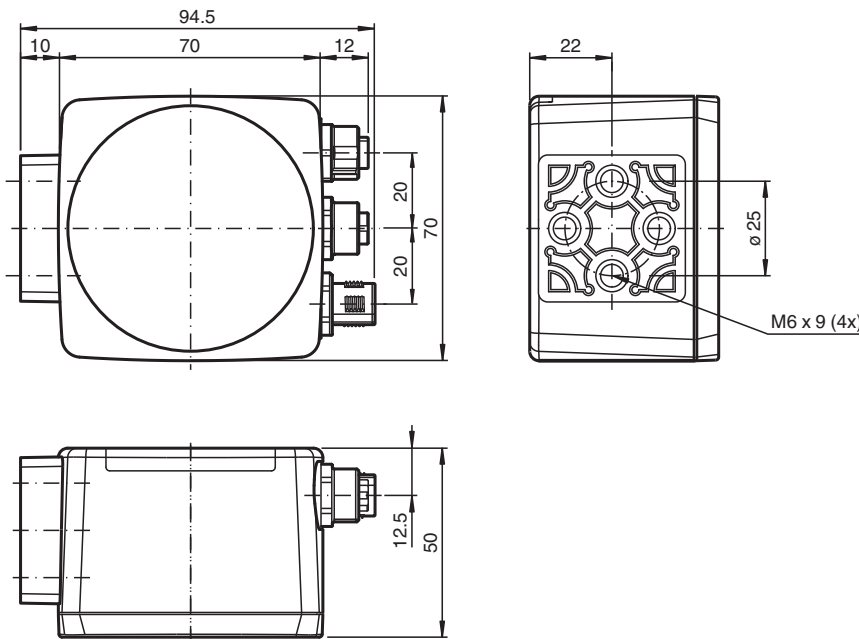

### Technical Data

#### General specifications

Passage speed	v	≤ 8 m/s
Measuring range		max. 10000 m
Light type		Integrated LED lightning (white/blue)
Scan rate		25 s <sup>-1</sup>
Latency		60 ms
Read distance		100 mm
Depth of focus		± 20 mm
Reading field		120 mm x 80 mm
Ambient light limit		100000 Lux

Release date: 2024-08-05 Date of issue: 2024-08-05 Filename: 258088\_eng.pdf

## Technical Data

Accuracy		± 0.2 mm
<b>Nominal ratings</b>		
Camera		
Type		CMOS , Global shutter
Processor		
Clock pulse frequency		600 MHz
Speed of computation		4800 MIPS
Digital resolution		32 Bit
<b>Functional safety related parameters</b>		
MTTF <sub>d</sub>		100 a
Mission Time (T <sub>M</sub> )		20 a
Diagnostic Coverage (DC)		0 %
<b>Indicators/operating means</b>		
LED indication		7 LEDs (communication, alignment aid, status information)
<b>Electrical specifications</b>		
Operating voltage	U <sub>B</sub>	15 ... 30 V DC , PELV
No-load supply current	I <sub>0</sub>	max. 400 mA
Power consumption	P <sub>0</sub>	6 W
<b>Interface</b>		
Interface type		PROFIBUS DP V0
Protocol		PROFIBUS DP acc. to EN 50170
Transfer rate		9.6; 19.2; 93.75; 187.5; 500; 1500 kBit/s 3; 6; 12 Mbit/s self-synchronizing
<b>Interface 2</b>		
Interface type		USB Service
<b>Input</b>		
Input type		1 function input 0-level: -U <sub>B</sub> or unwired 1-level: +8 V ... +U <sub>B</sub> , programmable
Input impedance		≥ 27 kΩ
<b>Output</b>		
Output type		1 to 3 switch outputs , PNP , programmable , short-circuit protected
Switching voltage		Operating voltage
Switching current		150 mA each output
<b>Conformity</b>		
Shock resistance		EN 60068-2-27:2009
Vibration resistance		EN 60068-2-6:2008
Emitted interference		EN 61000-6-4:2007+A1:2011
Noise immunity		EN 61000-6-2:2005
Photobiological safety		Risk group 1 according to EN 62471:2008
<b>Approvals and certificates</b>		
CE conformity		CE
UL approval		cULus Listed, Class 2 Power Source, Type 1 enclosure
CCC approval		CCC approval / marking not required for products rated ≤36 V
<b>Ambient conditions</b>		
Operating temperature		0 ... 60 °C (32 ... 140 °F) , -20 ... 60 °C (-4 ... 140 °F) (noncondensing; prevent icing on the lens!)
Relative humidity		90 % , noncondensing
<b>Mechanical specifications</b>		
Connection type		8-pin, M12x1 connector, standard (supply+IO) 5-pin, M12x1 socket, B-coded (Bus Out) 5-pin, M12x1 connector, B-coded (Bus In)
Degree of protection		IP67
Material		
Housing		PC/ABS

## Technical Data

Mass	approx. 200 g	
Dimensions		
Height		70 mm
Width		70 mm
Depth		50 mm
<b>Factory settings</b>		
X resolution (protocol)		0.1 mm
Y resolution (protocol)		0.1 mm
Speed resolution (protocol)		0.1 m/s
Angle resolution		0.1 °

## Connection

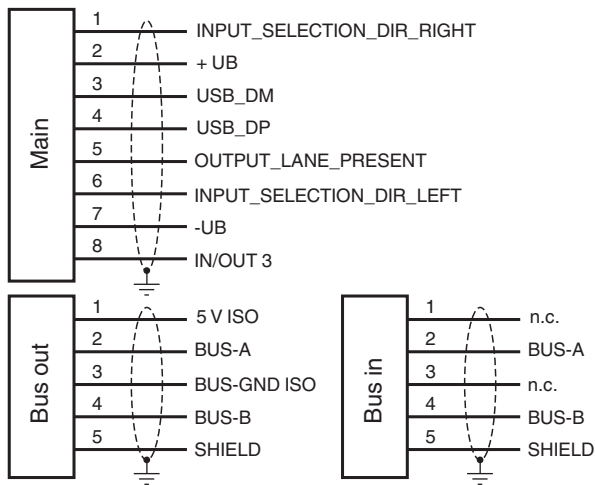

## Connection Assignment

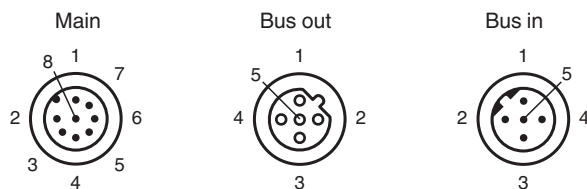

## Function Principle

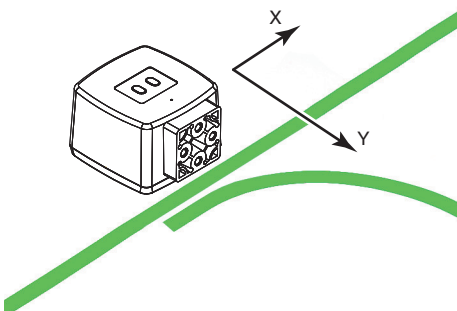

## Function Principle

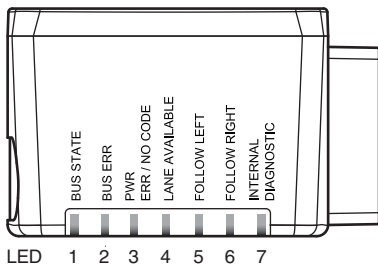
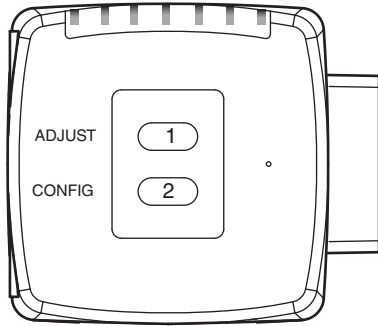

## Additional Information

### General

The PGV... reader forms part of the positioning system in the Pepperl+Fuchs incident light process. The reader's features include a camera module and an integrated illumination unit. The reader uses these features to detect a colored strip stuck to the floor to track the lane. The reader also detects control codes and position markers in the form of Data Matrix codes attached to a self-adhesive code tape. The code tape is usually mounted in a fixed position instead of the colored strip or parallel to the colored strip. The reader is located on the front of an automated guided vehicle and guides this vehicle along the colored strip.

### Mounting and Commissioning

Mount the reader such that the optical surface of the device captures the optimum reading distance to the colored strip (see "Technical Data"). The stability of the mounting and the manner in which the vehicle is guided ensure that the reader is not operated outside of its depth of focus range. The colored strip must not leave the maximum reading window for the reader during this process.

All readers can be adapted to optimally meet specific requirements by means of parameterization.

### Indicators and Operating Controls

The PGV... reader is equipped with seven indicator LEDs for carrying out visual function checks and rapid diagnostics. The reader is equipped with two buttons at the back for activating the alignment aid and parameterization mode.

#### LEDs

LED	Color	Label	Meaning
1	Yellow	BUS STATE	PROFIBUS communication active
2	Red	BUS ERR	PROFIBUS communication error
3	Green/red	PWR ERR/NO CODE	Code detected/not detected, error
4	Yellow	LANE AVAILABLE	Lane available
5	Yellow	FOLLOW LEFT	"Follow left-hand lane" activated
6	Yellow	FOLLOW RIGHT	"Follow right-hand lane" activated
7	Red/green/yellow	INTERNAL DIAGNOSTIC	Internal diagnostics

### External Parameterization

In order to parameterize the device externally, the parameterization code is required in the form of a Data Matrix containing the desired reader parameters. Data Matrix code cards detailing the step-by-step process for externally parameterizing the device are printed in the operating instructions for the reader.

The reader can be parameterized only within ten minutes of being switched on. If a key is pressed after ten minutes of the device being switched on, a visual signal is given by the LEDs (LED1, yellow/LED2, red/LED3, green/LED4, yellow/LED5, yellow/LED6, yellow, flashing for two seconds).

- The switchover from normal mode to parameterization mode is made by pressing button 2 on the back of the reader. To switch the device over, button 2 must be pressed and held for more than two seconds. LED4 then flashes.  
**Note:** Parameterization mode is exited automatically if the device is inactive for one minute. In this case, the reader reverts to normal mode and operates without the settings having been changed.
- Place the parameterization code in the field of vision of the camera module. After the parameterization code is detected, the green LED3 lights up for one second. In the event of an invalid parameterization code, LED3 lights up red for two seconds.
- Briefly pressing button 2 will end parameterization mode.