



Optical reading head PGV100-F200A-R4-V19

- Mechanically rugged: no wearing parts, long operating life, maintenance-free
- RS-485 interface
- Non-contact positioning on Data Matrix code tape
- Noncontact positioning with Data Matrix TAGs
- Noncontact lane tracking of a colored strip
- Reading of Data Matrix control codes
- White-blue light

Read head for incident light positioning system



Dimensions

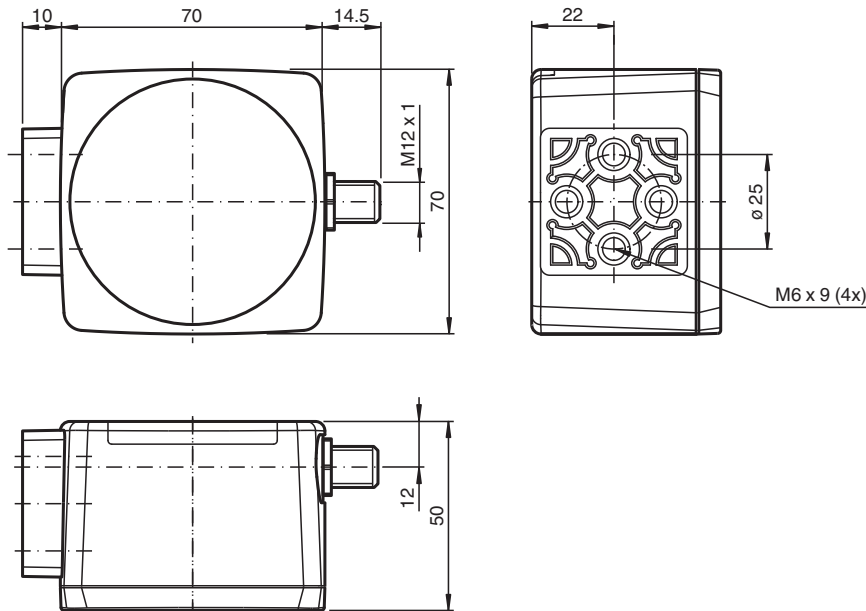

Technical Data

| General specifications | | |
|------------------------|---|---------------------------------------|
| Passage speed | v | ≤ 8 m/s |
| Measuring range | | max. 10000 m |
| Light type | | Integrated LED lightning (white/blue) |
| Scan rate | | 25 s ⁻¹ |
| Latency | | 60 ms |
| Read distance | | 100 mm |
| Depth of focus | | ± 20 mm |
| Reading field | | 120 mm x 80 mm |
| Ambient light limit | | 100000 Lux |
| Accuracy | | ± 0.2 mm |
| Nominal ratings | | |
| Camera | | |

Release date: 2024-08-05 Date of issue: 2024-08-05 Filename: 261183_eng.pdf

Technical Data

| | | | |
|---|---|-----------------------|--|
| Type | CMOS , Global shutter | | |
| Processor | | | |
| Clock pulse frequency | 600 MHz | | |
| Speed of computation | 4800 MIPS | | |
| Digital resolution | 32 Bit | | |
| Functional safety related parameters | | | |
| MTTF _d | 89 a | | |
| Mission Time (T _M) | 10 a | | |
| Diagnostic Coverage (DC) | 0 % | | |
| Indicators/operating means | | | |
| LED indication | 7 LEDs (communication, alignment aid, status information) | | |
| Electrical specifications | | | |
| Operating voltage | U _B | 15 ... 30 V DC , PELV | |
| No-load supply current | I ₀ | max. 200 mA | |
| Power consumption | P ₀ | 3 W | |
| Interface | | | |
| Interface type | RS 485 interface | | |
| Data output code | binary code | | |
| Transfer rate | 38400 ... 230400 Bit/s | | |
| Termination | Switchable terminal resistor | | |
| Query cycle time | ≥ 10 ms | | |
| Input | | | |
| Input type | 1 to 3 functional inputs , programmable | | |
| Input impedance | ≥ 27 kΩ | | |
| Output | | | |
| Output type | 1 to 3 switch outputs , PNP , programmable , short-circuit protected | | |
| Switching voltage | Operating voltage | | |
| Switching current | 150 mA each output | | |
| Conformity | | | |
| Shock resistance | EN 60068-2-27:2009 | | |
| Vibration resistance | EN 60068-2-6:2008 | | |
| Emitted interference | EN 61000-6-4:2007+A1:2011 | | |
| Noise immunity | EN 61000-6-2:2005 | | |
| Photobiological safety | Risk group 1 according to EN 62471:2008 | | |
| Approvals and certificates | | | |
| CE conformity | CE | | |
| UL approval | cULus Listed, Class 2 Power Source, Type 1 enclosure | | |
| CCC approval | CCC approval / marking not required for products rated ≤36 V | | |
| Ambient conditions | | | |
| Operating temperature | 0 ... 60 °C (32 ... 140 °F) , -20 ... 60 °C (-4 ... 140 °F) (noncondensing; prevent icing on the lens!) | | |
| Storage temperature | -20 ... 85 °C (-4 ... 185 °F) | | |
| Relative humidity | 90 % , noncondensing | | |
| Mechanical specifications | | | |
| Connection type | 8-pin, M12 x 1 connector | | |
| Degree of protection | IP67 | | |
| Material | | | |
| Housing | PC/ABS | | |
| Mass | approx. 160 g | | |
| Dimensions | | | |
| Height | 70 mm | | |
| Width | 70 mm | | |
| Depth | 50 mm | | |

Technical Data

Factory settings

| | |
|-----------------------------|--------------|
| X resolution (protocol) | 0.1 mm |
| Y resolution (protocol) | 0.1 mm |
| Speed resolution (protocol) | 0.1 m/s |
| Angle resolution | 0.1 ° |
| Baud rate | 115200 Bit/s |
| Extrapolation | On |
| Read head address | 0 |

Connection

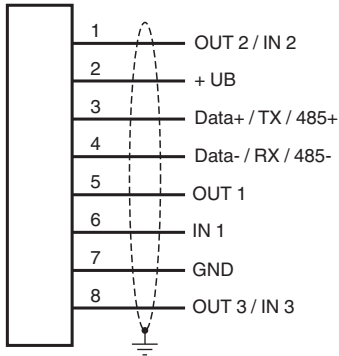

Connection Assignment

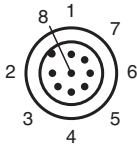

Function Principle

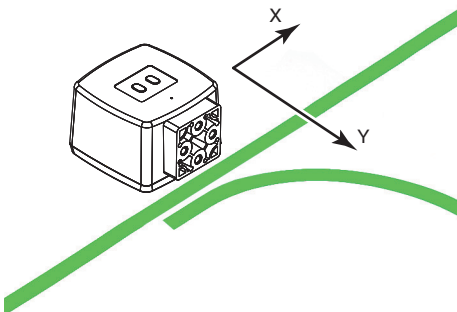

Release date: 2024-08-05 Date of issue: 2024-08-05 Filename: 261183_eng.pdf

Function Principle

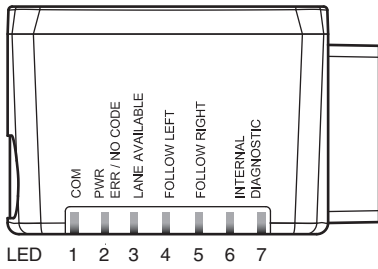
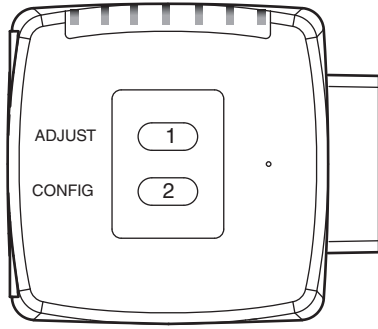

Additional Information

General

The PGV... reader forms part of the positioning system in the Pepperl+Fuchs incident light process. The reader's features include a camera module and an integrated illumination unit. The reader uses these features to detect a colored strip stuck to the floor to track the lane. The reader also detects control codes and position markers in the form of Data Matrix codes attached to a self-adhesive code tape. The code tape is usually mounted in a fixed position instead of the colored strip or parallel to the colored strip. The reader is located on the front of an automated guided vehicle and guides this vehicle along the colored strip.

Mounting and Commissioning

Mount the reader such that the optical surface of the device captures the optimum reading distance to the colored strip (see "Technical Data"). The stability of the mounting and the manner in which the vehicle is guided ensure that the reader is not operated outside of its depth of focus range. The colored strip must not leave the maximum reading window for the reader during this process. All readers can be adapted to optimally meet specific requirements by means of parameterization.

Indicators and Operating Controls

The PGV... reader is equipped with seven indicator LEDs for carrying out visual function checks and rapid diagnostics. The reader is equipped with two buttons at the back for activating the alignment aid and parameterization mode.

LEDs

| LED | Color | Label | Meaning |
|-----|------------------|--------------------|------------------------------------|
| 1 | Yellow | COM | Communication active |
| 2 | Green/red | PWR ERR/NO CODE | Code detected/not detected, error |
| 3 | Yellow | LANE AVAILABLE | Lane available |
| 4 | Yellow | FOLLOW LEFT | "Follow left-hand lane" activated |
| 5 | Yellow | FOLLOW RIGHT | "Follow right-hand lane" activated |
| 6 | Red/green/yellow | INTERNAL | Internal diagnostics |
| 7 | | DIAGNOSTIC | |

External Parameterization

In order to parameterize the device externally, the parameterization code is required in the form of a Data Matrix containing the desired reader parameters. Data Matrix code cards detailing the step-by-step process for externally parameterizing the device are printed in the operating instructions for the reader.

The reader can be parameterized only within ten minutes of being switched on. If a key is pressed after ten minutes of the device being switched on, a visual signal is given by the LEDs (LED1, yellow/LED2, red/LED3, yellow/LED4, yellow/LED5, yellow, flashing for two seconds).

- The switchover from normal mode to parameterization mode is made by pressing button 2 on the back of the reader. To switch the device over, button 2 must be pressed and held for more than two seconds. LED3 then flashes.
 - Note:** Parameterization mode is exited automatically if the device is inactive for one minute. In this case, the reader reverts to normal mode and operates without the settings having been changed.
- Place the parameterization code in the field of vision of the camera module. After the parameterization code is detected, the green LED2 lights up for one second. In the event of an invalid parameterization code, LED2 lights up red for two seconds.
- Briefly pressing button 2 will end parameterization mode.

Release date: 2024-08-05 Date of issue: 2024-08-05 Filename: 261183_eng.pdf