

# Switch Amplifier

## KFD2-SR3-Ex2.2S

- 2-channel isolated barrier
- 24 V DC supply (Power Rail)
- Dry contact or NAMUR inputs
- Usable as signal splitter (1 input and 2 outputs)
- 2 x 2 relay contact outputs with AND logic
- Reversible mode of operation
- Line fault detection (LFD)
- Up to SIL 2 (SC 3) acc. to IEC/EN 61508



### Function

This isolated barrier is used for intrinsic safety applications. The device transfers digital signals (NAMUR sensors or dry contacts) from a hazardous area to a safe area. Each input controls a relay contact output. Via switches the mode of operation can be reversed and the line fault detection can be switched off. A fault is signaled by LEDs acc. to NAMUR NE44 and a separate collective error message output.

### Connection

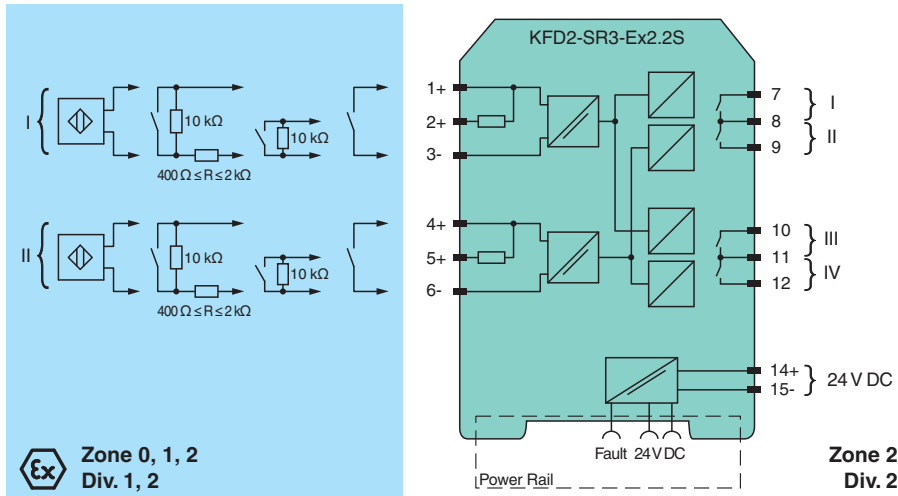

### Technical Data

#### General specifications

Signal type Digital Input

#### Functional safety related parameters

Safety Integrity Level (SIL) SIL 2

Systematic capability (SC) SC 3

#### Supply

Connection Power Rail or terminals 14+, 15-

Rated voltage  $U_r$  19 ... 30 V DC

Ripple  $\leq 10 \%$

Rated current  $I_r$  30 ... 20 mA

Power consumption  $< 600 \text{ mW}$

Release date: 2023-01-03 Date of issue: 2023-01-03 Filename: 262112\_eng.pdf

## Technical Data

<b>Input</b>		
Connection side		field side
Connection		terminals 1+, 2+, 3-; 4+, 5+, 6-
Rated values		acc. to EN 60947-5-6 (NAMUR)
Open circuit voltage/short-circuit current		approx. 10 V DC / approx. 8 mA
Switching point/switching hysteresis		1.2 ... 2.1 mA / approx. 0.2 mA
Line fault detection		breakage $I \leq 0.1$ mA , short-circuit $I \geq 6.5$ mA
Pulse/Pause ratio		min. 20 ms / min. 20 ms
<b>Output</b>		
Connection side		control side
Connection		output I: terminals 7, 8 ; output II: terminals 8, 9 ; output III: terminals 10, 11 ; output IV: terminals 11, 12
Output I, II, III, IV		channel 1, 2; relay
Contact loading		48 V AC/1 A/cos $\phi > 0.7$ ; 40 V DC/1 A resistive load
Minimum switch current		1 mA / 24 V DC
Energized/De-energized delay		approx. 20 ms / approx. 20 ms
Mechanical life		10 <sup>8</sup> switching cycles
Collective error message		Power Rail
<b>Transfer characteristics</b>		
Switching frequency		$\leq 10$ Hz
<b>Galvanic isolation</b>		
Input/Output		reinforced insulation according to IEC/EN 61010-1, rated insulation voltage 300 V <sub>eff</sub>
Input/power supply		reinforced insulation according to IEC/EN 61010-1, rated insulation voltage 300 V <sub>eff</sub>
Output/power supply		basic insulation according to IEC/EN 61010-1, rated insulation voltage 32 V <sub>eff</sub> , functional insulation, rated insulation voltage 50 V <sub>eff</sub>
Output/Output		basic insulation according to IEC/EN 61010-1, rated insulation voltage 32 V <sub>eff</sub> , functional insulation, rated insulation voltage 50 V <sub>eff</sub>
<b>Indicators/settings</b>		
Display elements		LEDs
Control elements		DIP switch
Configuration		via DIP switches
Labeling		space for labeling at the front
<b>Directive conformity</b>		
Electromagnetic compatibility		
Directive 2014/30/EU		EN 61326-1:2013 (industrial locations)
<b>Conformity</b>		
Electromagnetic compatibility		NE 21:2012 , EN 61326-3-2:2008
Degree of protection		IEC 60529:2001
Input		EN 60947-5-6:2000
<b>Ambient conditions</b>		
Ambient temperature		-20 ... 60 °C (-4 ... 140 °F)
<b>Mechanical specifications</b>		
Degree of protection		IP20
Connection		screw terminals
Mass		approx. 150 g
Dimensions		20 x 119 x 115 mm (0.8 x 4.7 x 4.5 inch) (W x H x D) , housing type B2
Mounting		on 35 mm DIN mounting rail acc. to EN 60715:2001
<b>Data for application in connection with hazardous areas</b>		
EU-type examination certificate		EXA 16 ATEX 0001 X
Marking		Ⓜ II 3(1)G Ex nA nC [ia Ga] IIC T4 Gc Ⓜ II (1)D [Ex ia Da] IIIC Ⓜ I (M1) [Ex ia Ma] I
Input		Ex ia
Voltage	U <sub>o</sub>	10.5 V
Current	I <sub>o</sub>	17.1 mA

**Technical Data**



Power	P <sub>o</sub>	45 mW (linear characteristic)
Supply		
Maximum safe voltage	U <sub>m</sub>	250 V AC (Attention! U <sub>m</sub> is no rated voltage.)
Output		
Maximum safe voltage	U <sub>m</sub>	250 V AC (Attention! The rated voltage can be lower.)
Galvanic isolation		
Input/Output		safe electrical isolation acc. to IEC/EN 60079-11, voltage peak value 375 V
Input/power supply		safe electrical isolation acc. to IEC/EN 60079-11, voltage peak value 375 V
Directive conformity		
Directive 2014/34/EU		EN 60079-0:2012+A11:2013 , EN 60079-11:2012 , EN 60079-15:2010
<b>International approvals</b>		
UL approval		E106378
Control drawing		116-0423 (cULus)
IECEx approval		
IECEx certificate		IECEx EXA 16.0001X
IECEx marking		Ex nA nC [ia Ga] IIC T4 Gc , [Ex ia Da] IIIC , [Ex ia Ma] I
<b>General information</b>		
Supplementary information		Observe the certificates, declarations of conformity, instruction manuals, and manuals where applicable. For information see <a href="http://www.pepperl-fuchs.com">www.pepperl-fuchs.com</a> .

**Assembly**

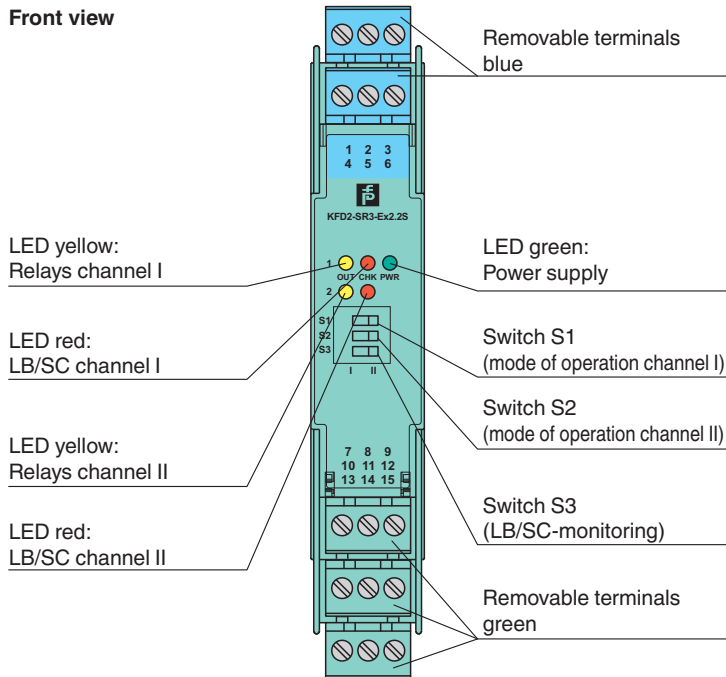
Front view







**Matching System Components**





	<b>KFD2-EB2</b>	Power Feed Module
	<b>UPR-03</b>	Universal Power Rail with end caps and cover, 3 conductors, length: 2 m

Release date: 2023-01-03 Date of issue: 2023-01-03 Filename: 262112\_eng.pdf

## Matching System Components

	<b>UPR-03-M</b>	Universal Power Rail with end caps and cover, 3 conductors, length: 1,6 m
	<b>UPR-03-S</b>	Universal Power Rail with end caps and cover, 3 conductors, length: 0.8 m
	<b>K-DUCT-BU</b>	Profile rail, wiring comb field side, blue
	<b>K-DUCT-BU-UPR-03</b>	Profile rail with UPR-03- * insert, 3 conductors, wiring comb field side, blue

## Accessories

	<b>F-NR3-Ex1</b>	NAMUR Resistor Network
	<b>KF-ST-5GN</b>	Terminal block for KF modules, 3-pin screw terminal, green
	<b>KF-ST-5BU</b>	Terminal block for KF modules, 3-pin screw terminal, blue
	<b>KF-CP</b>	Red coding pins, packaging unit: 20 x 6

**Configuration**

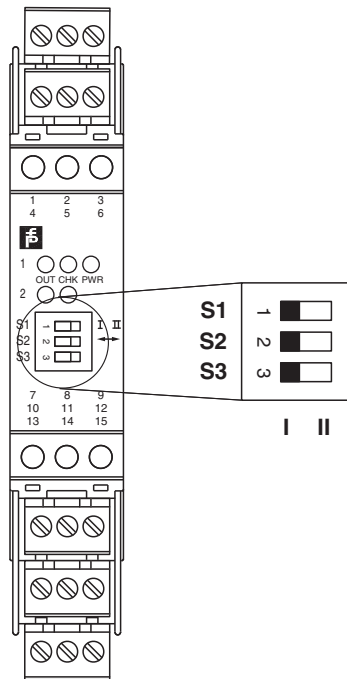

**Switch position**

S	Function		Position
1	Mode of operation channel I (relay) energized	with high input current	I
		with low input current	II
2	Mode of operation channel II (relay) energized	with high input current	I
		with low input current	II
3	Line fault detection	ON	I
		OFF	II

**Operating states**

Control circuit	Input signal
Initiator high impedance/contact opened	low input current
Initiator low impedance/contact closed	high input current
Lead breakage, lead short circuit	Line fault

Factory setting: switch 1, 2 and 3 in position I

**Characteristic Curve**

**Maximal Switching Power of Output Contacts**

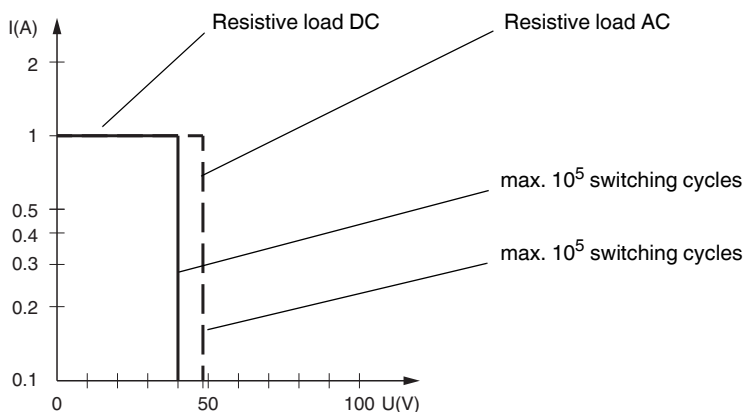

Release date: 2023-01-03 Date of issue: 2023-01-03 Filename: 262112\_eng.pdf

Release date: 2023-01-03 Date of issue: 2023-01-03 Filename: 262112\_eng.pdf