

## Optical reading head

### PCV100-F200-B25-V1D-6011

- Non-contact positioning on Data Matrix code tape
- Mechanically rugged: no wearing parts, long operating life, maintenance-free
- High resolution and precise positioning, especially for facilities with curves and switch points as well as inclines and declines.
- Travel ranges up to 10 km, in X and Y direction
- Integrated switch
- EtherNet/IP

Read head for incident light positioning system



**EtherNet/IP™**

## Dimensions

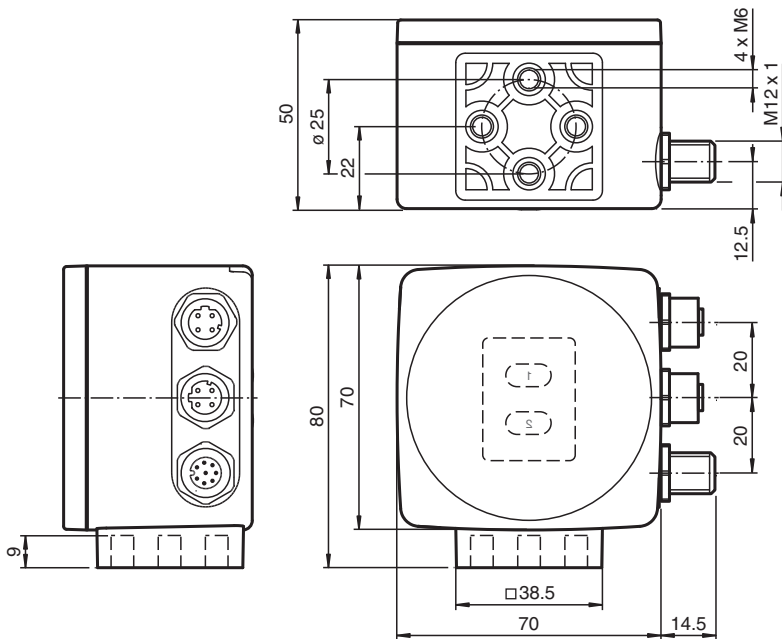

## Technical Data

### General specifications

|                     |   |                                |
|---------------------|---|--------------------------------|
| Passage speed       | v | ≤ 6 m/s                        |
| Measuring length    |   | max. 10000 m                   |
| Light type          |   | Integrated LED lightning (red) |
| Scan rate           |   | 40 s <sup>-1</sup>             |
| Read distance       |   | 100 mm                         |
| Depth of focus      |   | ± 40 mm                        |
| Reading field       |   | 60 mm x 40 mm                  |
| Ambient light limit |   | 100000 Lux                     |
| Resolution          |   | ± 0.1 mm                       |

### Nominal ratings

Camera

## Technical Data

|   |                |  |
|---|----------------|--|
| Type  |                | CMOS , Global shutter  |
| Processor                                   |                |  |
| Clock pulse frequency                       |                | 600 MHz  |
| Speed of computation                        |                | 4800 MIPS  |
| Digital resolution                          |                | 32 Bit   |
| <b>Functional safety related parameters</b> |                |  |
| MTTF <sub>d</sub>                           |                | 99 a   |
| Mission Time (T <sub>M</sub> )              |                | 20 a   |
| Diagnostic Coverage (DC)                    |                | 0 %  |
| <b>Indicators/operating means</b>           |                |  |
| LED indication                              |                | 7 LEDs (communication, alignment aid, status information)  |
| <b>Electrical specifications</b>            |                |  |
| Operating voltage                           | U <sub>B</sub> | 15 ... 30 V DC , PELV  |
| No-load supply current                      | I <sub>0</sub> | max. 400 mA  |
| Power consumption                           | P <sub>0</sub> | 6 W  |
| <b>Interface</b>                            |                |  |
| Interface type                              |                | 100 BASE-TX  |
| Protocol                                    |                | EtherNet/IP  |
| Transfer rate                               |                | 100 MBit/s   |
| <b>Interface 2</b>                          |                |  |
| Interface type                              |                | USB Service  |
| <b>Input</b>                                |                |  |
| Input type                                  |                | 1 funtion input<br>0-level: -U <sub>B</sub> or unwired<br>1-level: +8 V ... +U <sub>B</sub> , programmable               |
| Input impedance                             |                | ≥ 27 kΩ  |
| <b>Output</b>                               |                |  |
| Output type                                 |                | 1 to 3 switch outputs , programmable , short-circuit protected   |
| Switching voltage                           |                | Operating voltage  |
| Switching current                           |                | 150 mA each output   |
| <b>Conformity</b>                           |                |  |
| Photobiological safety                      |                | exempt group according to EN 62471:2008  |
| <b>Standard conformity</b>                  |                |  |
| Emitted interference                        |                | EN 61000-6-4:2007+A1:2011  |
| Noise immunity                              |                | EN 61000-6-2:2005  |
| Shock resistance                            |                | EN 60068-2-27:2009   |
| Vibration resistance                        |                | EN 60068-2-6:2008  |
| <b>Approvals and certificates</b>           |                |  |
| CE conformity                               |                | CE   |
| UKCA conformity                             |                | UKCA   |
| UL approval                                 |                | cULus Listed, General Purpose, Class 2 Power Source, Type 1 enclosure  |
| CCC approval                                |                | CCC approval / marking not required for products rated ≤36 V   |
| <b>Ambient conditions</b>                   |                |  |
| Operating temperature                       |                | 0 ... 60 °C (32 ... 140 °F) , -20 ... 60 °C (-4 ... 140 °F) (noncondensing; prevent icing on the lens!)                  |
| Storage temperature                         |                | -20 ... 85 °C (-4 ... 185 °F)  |
| Relative humidity                           |                | 90 % , noncondensing   |
| <b>Mechanical specifications</b>            |                |  |
| Connection type                             |                | 8-pin, M12x1 connector, standard (supply+IO)<br>4-pin, M12x1 socket, D-coded (LAN)<br>4-pin, M12x1 socket, D-coded (LAN) |
| Degree of protection                        |                | IP67   |
| Material                                    |                |  |
| Housing                                     |                | PC/ABS   |
| Mass  |                | approx. 200 g  |

### Technical Data

| Dimensions |       |
|------------|-------|
| Height     | 70 mm |
| Width      | 70 mm |
| Depth      | 50 mm |

### Connection

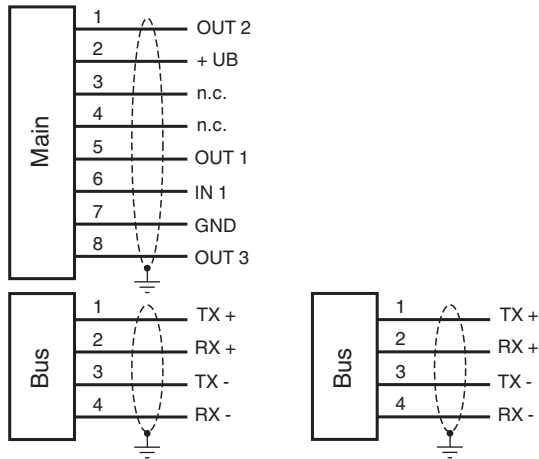

### Connection Assignment

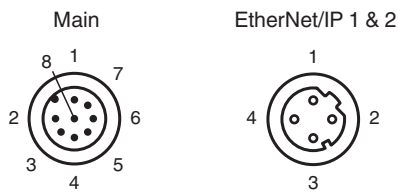

### Characteristic Curve

#### Coordinates

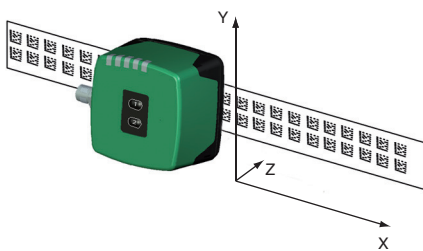

Release date: 2024-12-12 Date of issue: 2024-12-12 Filename: 262163\_eng.pdf

## Characteristic Curve

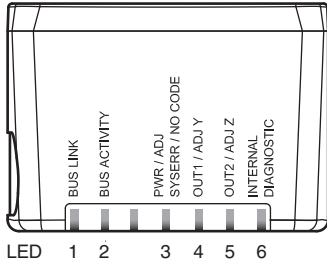
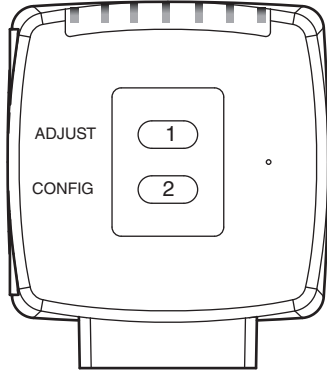

## Additional Information

### General

The reading head is part of the positioning system in the method for measurement by Pepperl+Fuchs. It consists of a camera module and an integrated illumination unit among other things. The reading head detects position marks, which are put on an adhesive code band in the form of Data Matrix code. The mounting of the code band is as a rule stationary on a firm part of the plant (elevator shaft, overhead conveyor mounting rails...); that of the reading head is parallel on the moving "vehicle" (elevator car, overhead conveyor chassis...).

### Mounting and commissioning

Mount the reading head such that its optical surface captures the optimal read distance to the code band (see Technical Data). The stability of the mounting and the guidance of the vehicle must be provided such that the depth of field of the reading head is not closed during operation. All reading heads can be optimally customized by parameterization for specific requirements.

### Displays and Controls

The reading head allows visual function check and fast diagnosis with 6 indicator LEDs. The reading head has 2 buttons on the reverse of the device to activate the alignment aid and parameterization mode.

### LEDs

| LED | Color            | Label                         | Meaning                                 |
|-----|------------------|-------------------------------|---|
| 1   | green            | BUS LINK                      | Communication status                    |
| 2   | yellow           | BUS ACTIVITY                  | Data transfer                           |
| 3   | red / green      | PWR / ADJ<br>SYSERR / NO CODE | Code recognized / not recognized, Error |
| 4   | yellow           | OUT1/ADJ Y                    | Output 1, Alignment aid Y               |
| 5   | yellow           | OUT2/ADJ Z                    | Output 2, Alignment aid Z               |
| 6   | red/green/yellow | INTERNAL<br>DIAGNOSTIC        | Internal diagnostics                    |

### Alignment aid for the Y and Z coordinates

The activation of the alignment aid is only possible within 10 minutes of switching on the reading head. The switchover from normal operation to "alignment aid operating mode" is via button 1 on the reverse of the reading head.

- Press the button 1 for longer than 2 s. LED3 flashes green for a recognized code band. LED3 flashes red for an unrecognized code band.
- **Z coordinate:** If the distance of the camera to the code band is too small, the yellow LED5 lights up. If the distance of the camera to the code band is too large, the yellow LED5 lights up. Within the target range, the yellow LED5 flashes at the same time as the green LED3.
- **Y coordinate:** If the optical axis of the camera is too deep in relation to the middle of the code band, the yellow LED4 lights up. If the optical axis is too high, the yellow LED4 extinguishes. Within the target range, the yellow LED4 flashes at the same time as the green LED3.
- A short press on button 1 ends the alignment aid and the reading head changes to normal operation.