

## Inductive positioning system

### PMI14V-F112-U-IO-V31

- Parameterization and diagnosis via IO-Link
- Analog output 0 ... 10 V
- Measuring range 0 ... 14 mm



## Dimensions

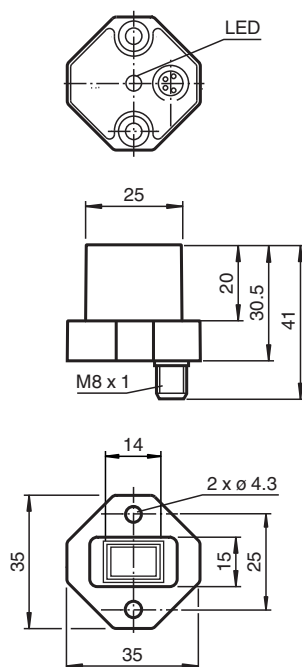

## Technical Data

### General specifications

Switching element function	Analog voltage output
Installation	flush
Object distance	max. 2.5 mm
Measurement range	0 ... 14 mm

### Nominal ratings

Operating voltage	$U_B$	18 ... 30 V DC
Reverse polarity protection		reverse polarity protected
Linearity error		$\pm 0.3$ mm
Repeat accuracy	R	$\pm 0.05$ mm

Release date: 2022-05-17 Date of issue: 2022-05-17 Filename: 263760\_eng.pdf

## Technical Data

Resolution		33 µm
Temperature drift		± 0.5 mm
No-load supply current	$I_0$	≤ 20 mA
Operating voltage indicator		LED green
<b>Functional safety related parameters</b>		
MTTF <sub>d</sub>		490 a
Mission Time (T <sub>M</sub> )		20 a
Diagnostic Coverage (DC)		0 %
<b>Interface</b>		
Interface type		IO-Link
Mode		COM2 (38.4 kBaud)
Value range		0000h ... 7000h
<b>Analog output</b>		
Output type		voltage output 0 ... 10 V
Load resistor		≥ 2000 Ω
Short-circuit protection		limited to 6 mA
<b>Compliance with standards and directives</b>		
Standard conformity		
Standards		EN 60947-5-2:2007 EN 60947-5-2/A1:2012 IEC 60947-5-2:2007 IEC 60947-5-2 AMD 1:2012 IEC 61131-9:2013
<b>Approvals and certificates</b>		
UL approval		cULus Listed, Class 2 Power Source, Type 1 enclosure
CCC approval		CCC approval / marking not required for products rated ≤36 V
<b>Ambient conditions</b>		
Ambient temperature		-25 ... 70 °C (-13 ... 158 °F)
<b>Mechanical specifications</b>		
Connection type		M8 x 1 connector, 4-pin
Housing material		diecast zinc, not laquered or coated
Degree of protection		IP67
Material		
Target		mild steel, e. g. 1.0037, SR235JR (formerly St37-2)
Note		The data relating to accuracy only apply to a distance to the object to be detected of 1 ... 2.5 mm.

## Connection

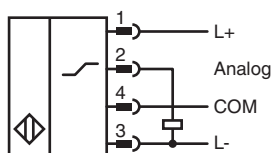

## Connection Assignment



Wire colors in accordance with EN 60947-5-2

1	BN	(brown)
2	WH	(white)
3	BU	(blue)
4	BK	(black)

## Installation Conditions

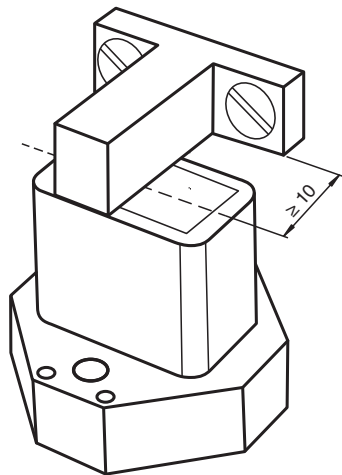
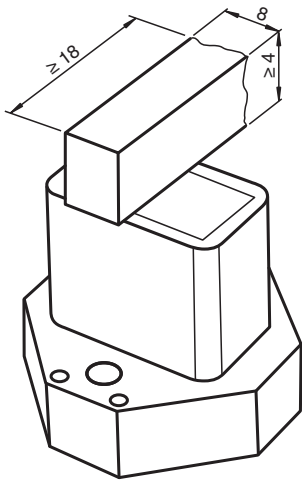





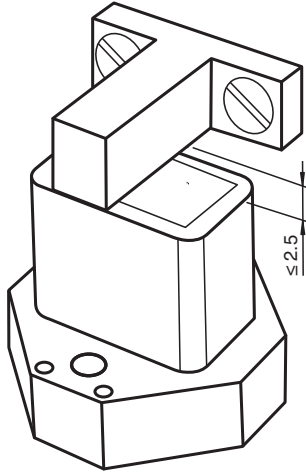







Release date: 2022-05-17 Date of issue: 2022-05-17 Filename: 263760\_eng.pdf

## Installation Conditions



## Accessories

	<b>BT-F90-W</b>	Damping element for sensors of type F90, F112, and F166; side hole
	<b>V31-GM-2M-PUR-V1-G</b>	Cordset M8 socket straight to M12 plug straight A-coded, 4-pin, PUR cable grey
	<b>BT-F90-G</b>	Damping element for sensors of type F90, F112, and F166; front hole
	<b>ICE2-8IOL-G65L-V1D</b>	EtherNet/IP IO-Link master with 8 inputs/outputs
	<b>ICE3-8IOL-G65L-V1D</b>	PROFINET IO IO-Link master with 8 inputs/outputs
	<b>ICE1-8IOL-G30L-V1D</b>	Ethernet IO-Link module with 8 inputs/outputs
	<b>ICE1-8IOL-G60L-V1D</b>	Ethernet IO-Link module with 8 inputs/outputs
	<b>ICE2-8IOL-K45P-RJ45</b>	EtherNet/IP IO-Link master with 8 inputs/outputs, DIN rail, push-in connectors
	<b>ICE2-8IOL-K45S-RJ45</b>	EtherNet/IP IO-Link master with 8 inputs/outputs, DIN rail, screw terminal
	<b>ICE3-8IOL-K45P-RJ45</b>	PROFINET IO IO-Link master with 8 inputs/outputs, DIN rail, push-in terminals
	<b>ICE3-8IOL-K45S-RJ45</b>	PROFINET IO IO-Link master with 8 inputs/outputs, DIN rail, screw terminal
	<b>IO-Link-Master02-USB</b>	IO-Link master, supply via USB port or separate power supply, LED indicators, M12 plug for sensor connection

## Technical Features

### Description of Sensor Functions

#### Additional Functions and Parameters (IO-Link)

Additional functions	Sensor temperature indicator Measuring range overrun and underrun indicator
Measuring range	Scalable measuring range Invertible measuring range
Analog output	Selectable output type (0 V..10 V; 1 V..5 V)

## Installation

### Information on Installation and Operation

#### Safety Information



Warnung

This product must not be used in applications in which the safety of persons depends on the function of the device. This product is not a safety component as specified in the EU Machinery Directive.

#### Actuator

The linear position measurement system is optimally aligned to the geometry of Pepperl+Fuchs actuators.

#### Using Your Own Actuators

Generally speaking, it is possible for you to use your own actuators. The specified measurement accuracy of the sensor will be achieved only if the actuator has the following properties:

- Material: construction steel such as S235JR+AR (previously St37)
- Dimensions (L x W x H):  $\geq 18 \text{ mm} \times 8 \text{ mm} \times \geq 4 \text{ mm}$
- The active surface of the actuator must protrude across the entire sensor width.

#### Note:

The width of the actuator must be precisely 8 mm. If the width of the actuator deviates from this value, the position values will differ.

#### Installation

- It is possible to flush mount the device.
- The distance between the center of the measurement field (framed area on the front panel of the sensor) and the fixing base or fixing elements (e.g., protruding screw heads) of the actuator must be at least 10 mm.

#### Operating Instructions

The specified measurement accuracy is achieved if the distance of the actuator from the sensor surface is max. 2.5 mm.

#### Definition of the Measuring Range/Measured Position

The measured position of the actuator is based on half of the width (center of the actuator).

The measuring range starts and ends when the actuator covers the measurement field marked on the sensor with half of its width in the course of its longitudinal movement.

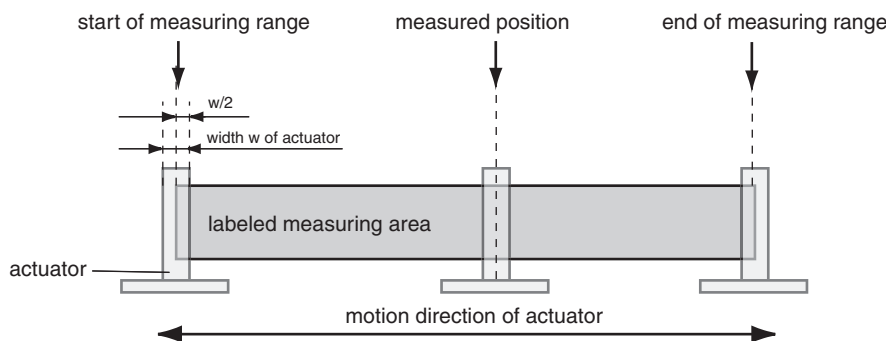

## Parameterization

Release date: 2022-05-17 Date of issue: 2022-05-17 Filename: 263760\_eng.pdf

**Supported IO-Link device parameters**

Index	Subindex	Name
Smart sensor profile parameters		
0x3A		Teach-In Channel
0x3B		Teach-In Status
0x3C	1, 2	BD1_SPV, Switching signal 1
0x3D	1, 2, 3	BD1_SPV, Switching signal 1 configuration
0x3E	1, 2	BD2_SPV, Switching signal 2
0x3F	1, 2, 3	BD2_SPV, Switching signal 2 configuration
0x4000	1, 2	BD3_SPV, Switching signal 3
0x4001	1, 2, 3	BD3_SPV, Switching signal 3 configuration
Device specific operation parameters		
0x40	1, 2, 3	Centered Window Width
0x42	1, 2	AD_SPC, Analog signal setpoint value
0x43	1, 2, 3	AD_SPC, Analog signal configuration
0x5F	1, 2, 3, 4, 5	Measurement data collection
Standard operation control		
0x70	1, 2, 3, 4, 5, 6, 7, 8	Output configuration
0x74		Event configuration
0x7F		Locator indication control
User information		
0xC0		UT1, User tag 1
0xC1		UT2, User tag 2
Special function		
0xE2		Operating temperature
0xE8	1, 2	Device characteristics

Details of the listed device parameters can be found in the manual.