

Inductive positioning system

PMI14V-F112-U-V3

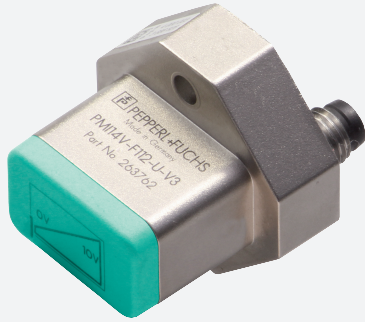

- Analog output 0 ... 10 V
- Scaleable measurement range, programmable via key
- Measuring range 0 ... 14 mm



Dimensions

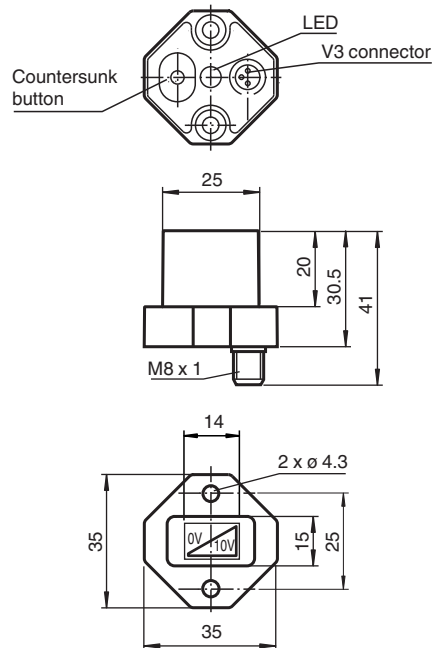

Technical Data

General specifications

Switching element function	Analog voltage output
Installation	flush
Object distance	max. 2.5 mm
Measurement range	0 ... 14 mm

Nominal ratings

Operating voltage	U_B	18 ... 30 V DC
Reverse polarity protection		reverse polarity protected
Linearity error		± 0.3 mm
Repeat accuracy	R	± 0.05 mm

Release date: 2022-05-17 Date of issue: 2022-05-17 Filename: 263762_eng.pdf

Technical Data

Resolution		33 μm
Temperature drift		$\pm 0.4 \text{ mm}$
No-load supply current	I_0	$\leq 20 \text{ mA}$
Operating voltage indicator		LED
Functional safety related parameters		
MTTF _d		490 a
Mission Time (T _M)		20 a
Diagnostic Coverage (DC)		0 %
Analog output		
Output type		1 voltage output: 0 ... 10 V
Load resistor		$\geq 2000 \Omega$
Short-circuit protection		limited to 6 mA
Compliance with standards and directives		
Standard conformity		
Standards		EN 60947-5-2:2007 EN 60947-5-2/A1:2012 IEC 60947-5-2:2007 IEC 60947-5-2 AMD 1:2012
Approvals and certificates		
UL approval		cULus Listed, Class 2 Power Source, Type 1 enclosure
CCC approval		CCC approval / marking not required for products rated $\leq 36 \text{ V}$
Ambient conditions		
Ambient temperature		-25 ... 70 °C (-13 ... 158 °F)
Mechanical specifications		
Connection type		M8 x 1 connector, 3-pin
Housing material		diecast zinc, not laquered or coated
Degree of protection		IP67
Material		
Target		mild steel, e. g. 1.0037, SR235JR (formerly St37-2)
Note		The data relating to accuracy only apply to a distance to the object to be detected of 1 ... 2.5 mm.

Connection

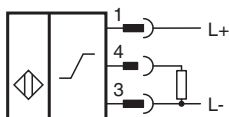

Connection Assignment



Connection Assignment

Wire colors in accordance with EN 60947-5-2

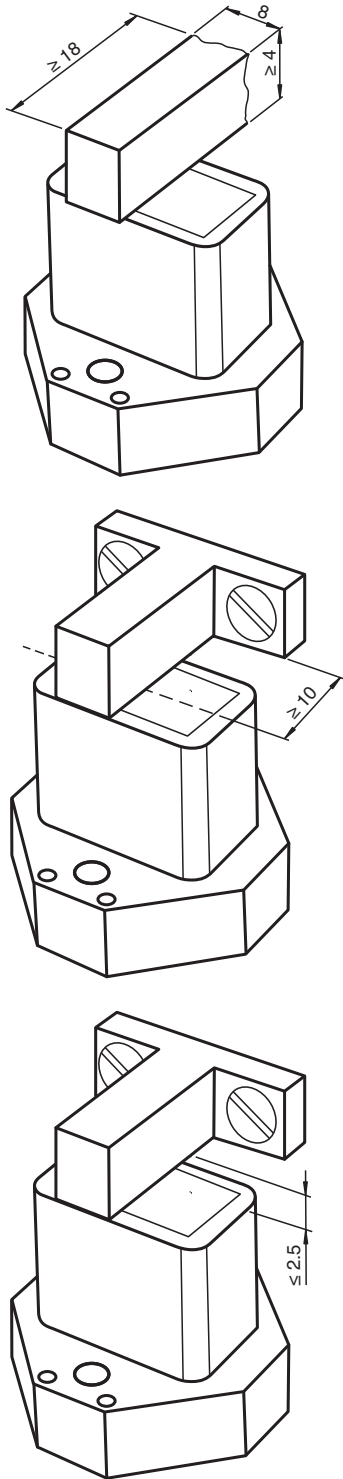

1	BN	(brown)
3	BU	(blue)
4	BK	(black)

Installation Conditions



Release date: 2022-05-17 Date of issue: 2022-05-17 Filename: 263762_eng.pdf

Accessories

	BT-F90-W	Damping element for sensors of type F90, F112, and F166; side hole
	V3-WM-2M-PUR	Female cordset single-ended M8 angled A-coded, 3-pin, PUR cable grey
	BT-F90-G	Damping element for sensors of type F90, F112, and F166; front hole

Installation

Information on Installation and Operation

Safety Information



Warnung

This product must not be used in applications in which the safety of persons depends on the function of the device. This product is not a safety component as specified in the EU Machinery Directive.

Actuator

The linear position measurement system is optimally aligned to the geometry of Pepperl+Fuchs actuators.

Using Your Own Actuators

Generally speaking, it is possible for you to use your own actuators. The specified measurement accuracy of the sensor will be achieved only if the actuator has the following properties:

- Material: construction steel such as S235JR+AR (previously St37)
- Dimensions (L x W x H): $\geq 18 \text{ mm} \times 8 \text{ mm} \times \geq 4 \text{ mm}$
- The active surface of the actuator must protrude across the entire sensor width.

Note:

The width of the actuator must be precisely 8 mm. If the width of the actuator deviates from this value, the position values will differ.

Installation

- It is possible to flush mount the device.
- The distance between the center of the measurement field (framed area on the front panel of the sensor) and the fixing base or fixing elements (e.g., protruding screw heads) of the actuator must be at least 10 mm.

Operating Instructions

The specified measurement accuracy is achieved if the distance of the actuator from the sensor surface is max. 2.5 mm.

Definition of the Measuring Range/Measured Position

The measured position of the actuator is based on half of the width (center of the actuator).

The measuring range starts and ends when the actuator covers the measurement field marked on the sensor with half of its width in the course of its longitudinal movement.

