

## 2-D LiDAR Sensor

### OMD8000-R2100-R2-2V15



- Measuring method PRT (Pulse Ranging Technology)
- Distance measurement using object
- Two-dimensional measurement with no moving parts
- Measurement using eye-safe LED technology
- 88° scanning angle

Multi-ray LED scanner for measuring the distance to an object, measuring method: PRT, measuring range: up to 8 m on white, 2x M12 plugs



### Function

The new 2-dimensional multi-ray LED scanner uses tried-and-tested Pulse Ranging Technology and boasts a wide range of user-friendly features. The eye-safe LED technology in the sensor allows it to be used by personnel in all working areas without posing a danger. The 11 emitter elements arranged side by side span a scanning range of 88 degrees, while the emitter LEDs set themselves apart through their large light spot. Measuring on a surface rather than on a point makes it easier to measure inhomogeneous surfaces. A further highlight is the absence of any moving parts such as a motor or bearings, which makes the device less complex in its design and more resistant to mechanical stress.

### Dimensions

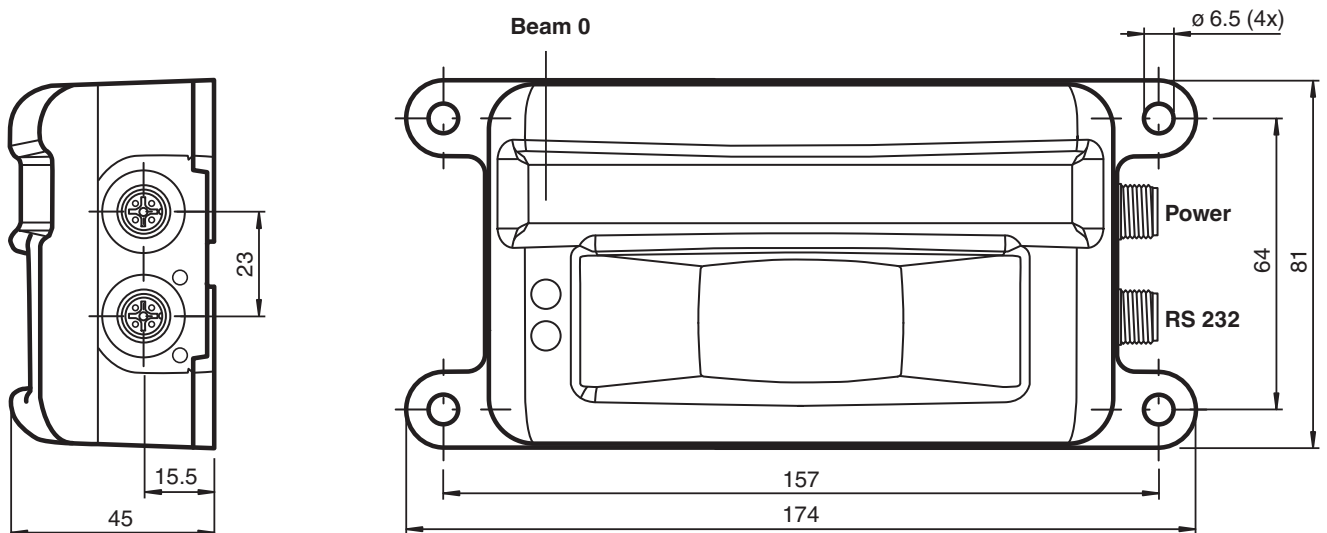

Release date: 2023-04-04 Date of issue: 2023-04-04 Filename: 264888\_eng.pdf

## Technical Data

General specifications		
Measurement range		0.2 ... 2 m (bw 6%) 0.2 ... 8 m (wh 90%)
Light source		IREDD
Light type		modulated infrared light , 850 nm
Measuring method		Pulse Ranging Technology (PRT)
Scan rate		50 s <sup>-1</sup> (1 scan = 11 measurements)
Scanning angle		88°
Diameter of the light spot		550 mm at 4 m (orthogonal)
Ambient light limit		> 80000 Lux
Resolution		1 mm
Functional safety related parameters		
MTTF <sub>d</sub>		123 a
Mission Time (T <sub>M</sub> )		20 a
Diagnostic Coverage (DC)		0 %
Indicators/operating means		
Operation indicator		LED green
Function indicator		LED yellow
Electrical specifications		
Operating voltage	U <sub>B</sub>	10 ... 30 V DC
Ripple		10 % within the supply tolerance
No-load supply current	I <sub>0</sub>	≤ 120 mA / 24 V DC
Protection class		III
Time delay before availability	t <sub>v</sub>	< 3 s
Interface		
Interface type		RS 232
Protocol		P+F R2100 115k, 8N1
Conformity		
Product standard		EN 60947-5-2
Measurement accuracy		
Measured value noise		20 mm (1 sigma, 4 m on white, orthogonal)
Angle resolution		8 °
Absolute accuracy		+/- 50 mm (orthogonal)
Approvals and certificates		
UL approval		cULus Listed, Class 2 Power Source, Type 1 enclosure
CCC approval		CCC approval / marking not required for products rated ≤36 V
Ambient conditions		
Ambient temperature		-30 ... 60 °C (-22 ... 140 °F) UL: -10 ... 50 °C (14 ... 122 °F)
Storage temperature		-30 ... 70 °C (-22 ... 158 °F)
Relative humidity		95 % , no moisture condensation
Mechanical specifications		
Housing width		81 mm
Housing height		45 mm
Degree of protection		IP67
Connection		5-pin, M12x1 connector, standard (supply; color black) 5-pin, M12x1 connector, standard (RS 232; color grey; shielded)
Material		
Housing		plastic
Optical face		Lexan (PC)
Mass		approx. 250 g

## Connection Assignment

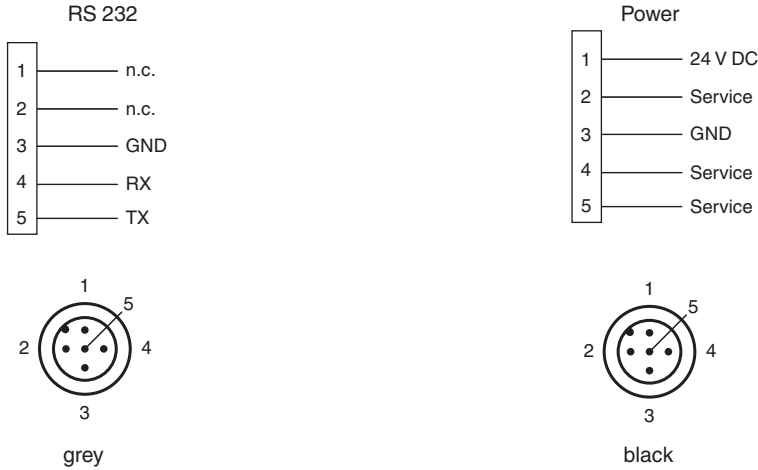

## Assembly

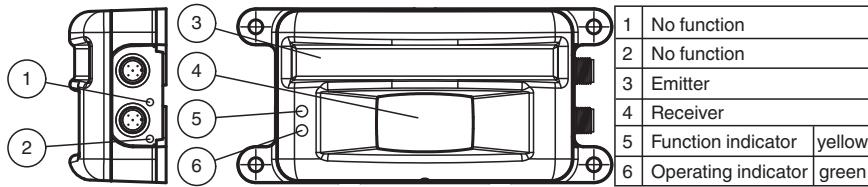

## Installation

### Installation Instructions for North America

If a connection is made to the M12 multi-pin connector, the product shall be used with a UL-listed cable/connector (CYJV) assembly rated minimum 30 V DC, minimum 1.0 A, in the final installation for power supply.

## Characteristic Curve

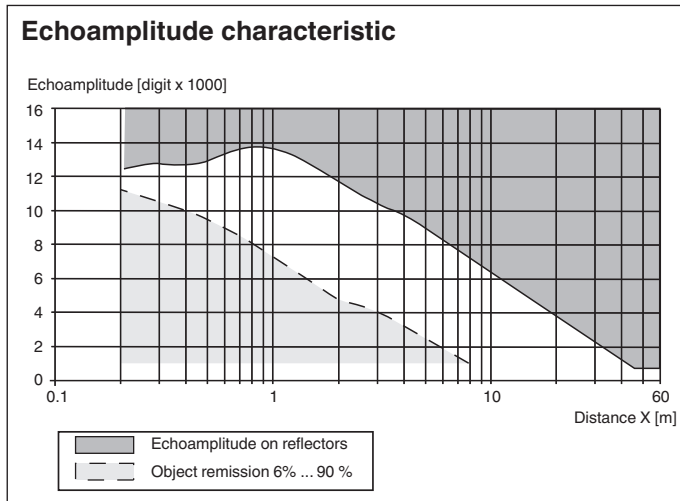

Release date: 2023-04-04 Date of issue: 2023-04-04 Filename: 264888\_eng.pdf

**Characteristic Curve**

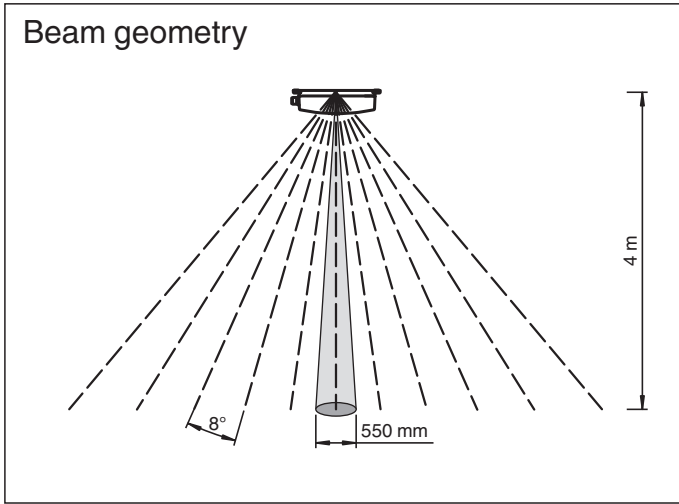

**Accessories**

	<b>V1-G-2M-PUR</b>	Female cordset single-ended M12 straight A-coded, 4-pin, PUR cable grey
	<b>V1-W-2M-PUR</b>	Female cordset single-ended M12 angled A-coded, 4-pin, PUR cable grey
	<b>V15-G-5M-PUR-ABG</b>	Female cordset single-ended M12 straight A-coded, 5-pin, PUR cable grey, shielded
	<b>V1-G-BK5M-PUR-U</b>	Female cordset single-ended M12 straight A-coded, 4-pin, PUR cable black, UL approved, drag chain suitable, torsion resistant
	<b>V1-W-BK5M-PUR-U</b>	Female cordset single-ended M12 angled A-coded, 4-pin, PUR cable black, UL approved, drag chain suitable, torsion resistant
	<b>V15-G-2M-PVC-SUBD9</b>	Adapter cable M12 socket straight A-coded 5-pin to Sub-D-plug 9-pin, PVC cable grey

Release date: 2023-04-04 Date of issue: 2023-04-04 Filename: 264888\_eng.pdf