



## Ultrasonic sensor

### UBH60/30-12GM-I-V1-Y266698

- Thickness measurement with analog output 4 ... 20 mA
- Extremely narrow projection cone
- Short response time
- Calibration of the reference distance via function input

Single head system



## Dimensions

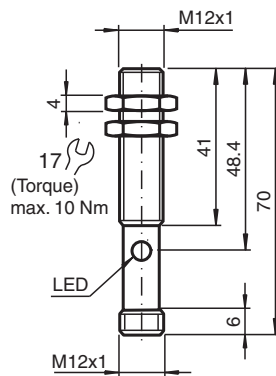

## Technical Data

### General specifications

Measuring range		object thickness (d) : 0 ... 30 mm
Dead band		0 ... 15 mm
Reference distance	h	50 ... 60 mm
Standard target plate		10 mm x 10 mm
Transducer frequency		approx. 850 kHz
Response delay		approx. 12 ms

### Indicators/operating means

LED yellow		solid yellow: object in the evaluation range yellow, flashing: program function, object detected
LED red		solid red: Error red, flashing: program function, object not detected

### Electrical specifications

Operating voltage	$U_B$	10 ... 30 V DC , ripple 10 % <sub>SS</sub>
No-load supply current	$I_0$	≤ 30 mA
Time delay before availability	$t_v$	≤ 200 ms

### Input

Input type		1 function input 0-level: $-U_B$ or unwired 1-level: +4 V ... $+U_B$ input impedance: > 4.7 kΩ
------------	--	---

### Output

Release date: 2025-05-22 Date of issue: 2025-05-22 Filename: 266698\_eng.pdf

## Technical Data

Output type	1 analog output 4 ... 20 mA	
Resolution		0.17 mm
Deviation of the characteristic curve	± 1 % of full-scale value	
Repeat accuracy	± 0.5 % of full-scale value	
Load impedance	0 ... 300 Ohm	
<b>Compliance with standards and directives</b>		
Standard conformity		
Standards	EN IEC 60947-5-2:2020 IEC 60947-5-2:2019 EN 60947-5-7:2003 IEC 60947-5-7:2003	
<b>Approvals and certificates</b>		
UL approval	cULus Listed, Class 2 Power Source	
CCC approval	CCC approval / marking not required for products rated ≤36 V	
<b>Ambient conditions</b>		
Ambient temperature	-25 ... 70 °C (-13 ... 158 °F)	
Storage temperature	-40 ... 85 °C (-40 ... 185 °F)	
<b>Mechanical specifications</b>		
Connection type	Connector plug M12 x 1 , 4-pin	
Degree of protection	IP67	
Material		
Housing	brass, nickel-plated	
Transducer	epoxy resin/hollow glass sphere mixture; foam polyurethane, cover PBT	
Mass	25 g	
Dimensions		
Length	70 mm	
Diameter	12 mm	

## Connection Assignment

Standard symbol/Connections:

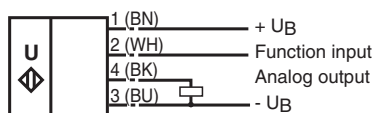

Core colors in accordance with EN 60947-5-2.

## Connection Assignment

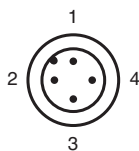

## Connection Assignment

Wire colors in accordance with EN 60947-5-2

1	BN	(brown)
2	WH	(white)
3	BU	(blue)
4	BK	(black)

## Installation Conditions

If the sensor is installed at places where the environment temperature can fall below 0 °C, for the sensors fixation, one of the mounting flanges BF 12, BF 12-F or BF 5-30 must be used. In case of direct mounting of the sensor in a through hole, it has to be fixed at the middle of the housing thread.

## Characteristic Curve

### Characteristic response curve

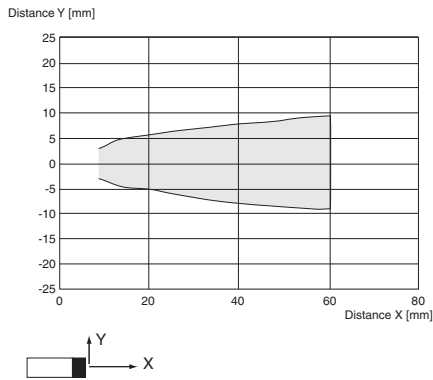

### Mounting

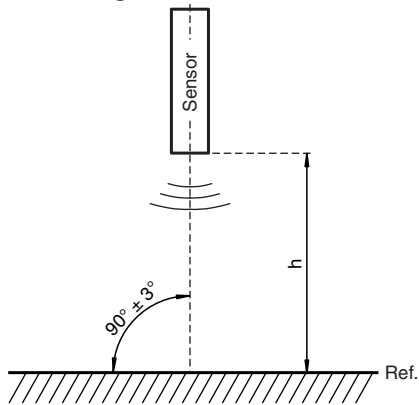

Release date: 2025-05-22 Date of issue: 2025-05-22 Filename: 266698\_eng.pdf

## Characteristic Curve

### Normal mode

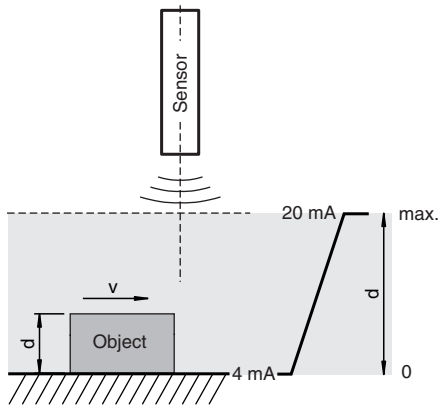

## Programming

The sensor features a programmable analog output with two programmable evaluation boundaries. Programming the evaluation boundaries and the operating mode is done by applying the supply voltage  $-U_B$  or  $+U_B$  to the Teach-In input. The supply voltage must be applied to the Teach-In input for at least 1 s. LEDs indicate whether the sensor has recognized the target during the programming procedure.

### Note:

Evaluation boundaries may only be specified directly after Power on. A time lock secures the adjusted switching points against unintended modification 5 minutes after Power on. To modify the evaluation boundaries later, the user may specify the desired values only after a new Power On.

### Note:

If a programming adapter UB-PROG2 is used for the programming procedure, button A1 is assigned to  $-U_B$  and button A2 is assigned to  $+U_B$ .

### Programming the analog output

#### Rising ramp

1. Place the target at the near end of the desired evaluation range
2. Program the evaluation boundary by applying  $-U_B$  to the Teach-In input (yellow LED flashes)
3. Disconnect the Teach-In input from  $-U_B$  to save the evaluation boundary
4. Place the target at the far end of the desired evaluation range
5. Program the evaluation boundary by applying  $+U_B$  to the Teach-In input (yellow LED flashes)
6. Disconnect the Teach-In input from  $+U_B$  to save the evaluation boundary

#### Falling ramp

1. Place the target at the far end of the desired evaluation range
2. Program the evaluation boundary by applying  $-U_B$  to the Teach-In input (yellow LED flashes)
3. Disconnect the Teach-In input from  $-U_B$  to save the evaluation boundary
4. Place the target at the near end of the desired evaluation range
5. Program the evaluation boundary by applying  $+U_B$  to the Teach-In input (yellow LED flashes)
6. Disconnect the Teach-In input from  $+U_B$  to save the evaluation boundary