

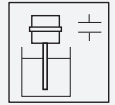

Capacitive limit switch

LCL1



- Limit switch for bulk solids
- Device with rod probe
- Complete unit consisting of the probe and electronic insert
- Integrated active build-up compensation: exact switch point, even with strong build-up
- Mechanically rugged: no wearing parts, long operating life, maintenance-free



Function

The capacitive limit switch is designed for limit detection of light bulk solids, e. g. grain products, flour, milk powder, animal feed, cement, chalk or plaster.

Versions:

- Device with 140 mm (5.5 inch) rod probe, for bulk solids
- Relay output (potential-free change-over contact) with AC or DC connection
- PNP output with 3-wire DC connection

Connection

Connection type E5, 3-wire DC connection (example)

3-wire DC connection

F: Fine-wire fuse, 500 mA

R: connected load, e. g. PLC, DCS, relay

M: Connection to ground, silo or metal parts silo

E: Grounding

The LCL is protected against reverse polarity. In case of mixing up the connections, the green LED does not illuminate "ready to operate".

PE-connection and PAL-connection for LCL1 are unnecessary.

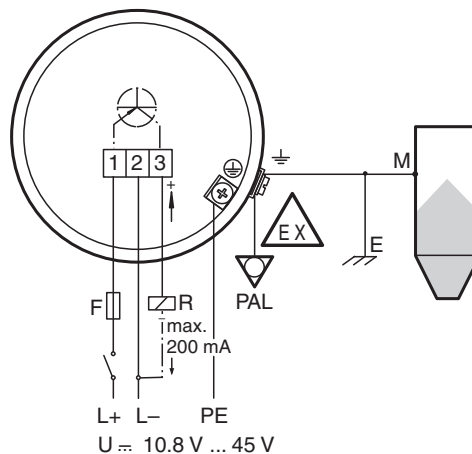

Other connection types see section electrical connection.

Dimensions

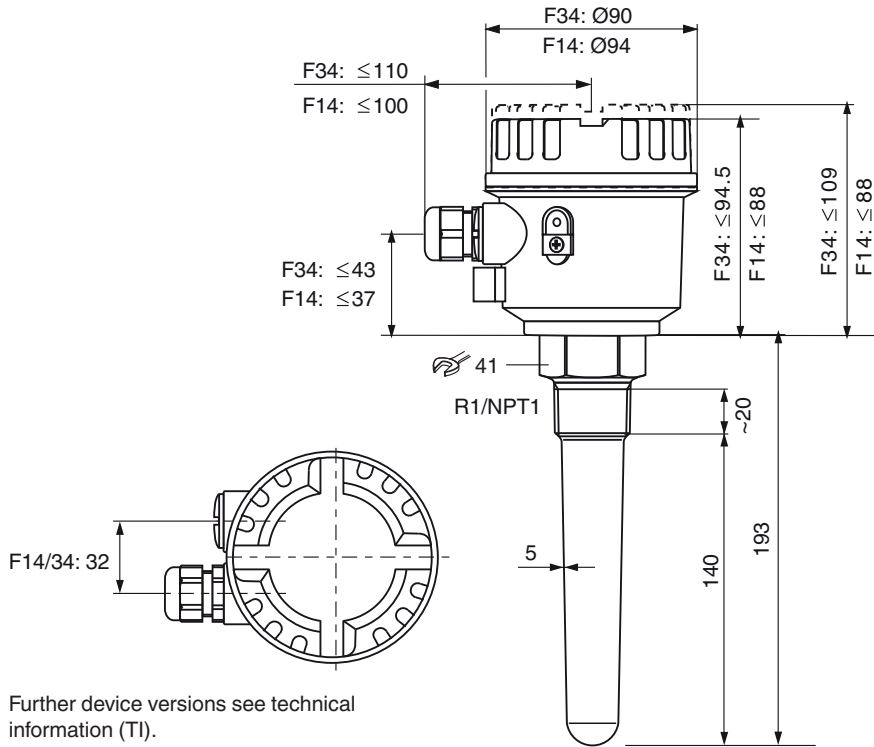

Technical Data

General specifications	
Measuring method	A metal plate at the end of the probe, within the insulation, and the surroundings (e. g. the silo walls) combine to form the two electrodes of a capacitor. If the probe is covered or free of material, then the capacitance changes and the LCL switches.
Equipment architecture	The measuring system consists of: - the device - a supply point - the connected control systems, switching units, signalling systems (e. g. lamps, horns, PCS, PLC, etc.)
Construction type	device with rod probe
Operating mode	MAX = maximum safety: The device switches if the probe is covered or if the supply voltage is disconnected in a safety-oriented manner (signal on alarm). example application: overspill protection MIN = minimum safety: The device switches if the probe is uncovered or if the supply voltage is disconnected in a safety-oriented manner (signal on alarm). example application: dry-running protection
Series	LCL1
Supply	
Rated voltage	U_r electrical connection E5: 10.8 ... 45 V DC, short-term pulse on 55 V DC electrical connection WA: 20 ... 235 V AC, 50/60 Hz or 20 ... 55 V DC
Current consumption	electrical connection E5: max. 30 mA, reverse-polarity-proof electrical connection WA: max. 130 mA
Electrical specifications	
Surge protection	overvoltage category III
Input	

Release date: 2025-01-27 Date of issue: 2025-01-27 Filename: 271947_eng.pdf

Technical Data

Measured variable		limit level (limit value)
Measuring range		dielectric constant ≥ 1.6
Output		
Switch-on delay	t_{on}	correct switching after max. 1.5 s
Output signal		connection E5: switching PNP, $I_{max} = 200$ mA - overload and short circuit protection - residual voltage at transistor at $I_{max} < 2.9$ V connection WA: contact change-over, potential-free - $U_{max} = 253$ V - $I_{max} = 4$ A (AC) - $P_{max} = 1000$ VA, $\cos \phi = 1$, $P_{max} = 500$ VA, $\cos \phi > 0.7$
Signal on alarm		connection E5: < 100 μ A connection WA: relay de-energized
Directive conformity		
Electromagnetic compatibility		
Directive 2014/30/EU		EN 61326-1:2006 , EN 61326-2-3:2006
Low voltage		
Directive 2014/35/EU		EN 61010-1:2010
Conformity		
Electromagnetic compatibility		
Degree of protection		NE 21
Degree of protection		IEC 60529:2001
Vibration resistance		EN 60068-2-64
Climate class		EN 60068, part 2-38 (test Z/AD)
Measurement accuracy		
Reference operating conditions		vessel type: plastic vessel, ambient temperature: 73 °F (23 °C, 296 K), medium temperature: 73 °F (23 °C, 296 K) medium pressure p_e : 0 bar, medium: dielectric constant = 2.6, conductivity: < 1 μ S sensitivity setting: C
Hysteresis		horizontal 4 mm (0.16 inch), vertical 7 mm (0.28 inch)
Long-term drift		horizontal 3 mm (0.12 inch), vertical 6 mm (0.24 inch)
Influence of medium temperature		depending on the filling material
Switching time		approx. 0.5 s when covering and uncovering the sensor
Operating conditions		
Installation conditions		
Installation position		any position
Mounting location		The capacitive limit switch can be installed in silos made of different materials (e. g. metal, plastic, concrete).
Process conditions		
Process temperature		-40 ... 130 °C (-40 ... 266 °F) -40 ... 80 °C (-40 ... 176 °F) (Dust-Ex version)
Medium pressure limits		-1 ... 25 bar
State of aggregation		solids
Solid contents		$\leq \varnothing 30$ mm
Bulk density		≤ 200 g/l
Ambient conditions		
Ambient temperature		-40 ... 80 °C (-40 ... 176 °F) -40 ... 60 °C (-40 ... 140 °F) (Dust-Ex version)
Storage temperature		-40 ... 80 °C (-40 ... 176 °F)
Shock resistance		device with F34 housing: 7 J
Vibration resistance		$a(\text{RMS}) = 50$ m/s ² , ASD = 1.25 (m/s ²) ² /Hz, f = 5 to 2000 Hz, t = 3 x 2 h
Mechanical specifications		
Degree of protection		IP66, NEMA 4
Connection		gland M20 thread G1/2, NPT1/2
Material		F14 housing: polyester PBT-FR F34 housing F34: aluminum Probe: PPS GF40
Dimensions		max. $\varnothing 94$ mm (3.7 inch), length 391 mm (15.4 inch)

Technical Data

Process connection	thread R1 acc. to EN 10226, BSPT, adapter for R1-1/2 and G1-1/2 see accessories thread NPT1 to ANSI B 1.20.1, adapter for NPT1-1/4 see accessories
Data for application in connection with hazardous areas	
EU-type examination certificate	see instruction manuals (SI)
Directive conformity	
Directive 2014/34/EU	EN 60079-0:2012+A11:2013 , EN 60079-11:2012 , EN 60079-31:2009
General information	
Supplementary documentation	technical information (TI) manuals, brief instructions (BA, KA) instruction manuals (SI)
Supplementary information	Observe the certificates, declarations of conformity, instruction manuals, and manuals where applicable. For information see www.pepperl-fuchs.com .
Accessories	
Designation	- LCL-Z10 cover with sight glass for F14 housing - LCL-Z11 adapter for R1-1/2, EN 10226 - LCL-Z12 adapter for G1-1/2, DIN ISO 228 - LCL-Z13 adapter for NPT1-1/4, steel - LCL-Z15 adapter for NPT1-1/4, 1.4571

Type Code

This overview does not mark options which are mutually exclusive.

L	C	L	1	-	(1)	K	-	(2)	(3)	(4)	-	(5)
LCL		Device										
LCL		Capacitive limit switch										
1		Design										
1		Device with rod probe										
(1)		Process connection										
Threads												
N3		NPT1, ANSI, PPS										
R3		R1, EN 10226, PPS										
K		Probe length										
K		140 mm										
(2)		Housing										
C		Polyester housing F14, IP66, NEMA 4, thread NPT1/2										
H		Aluminium housing F34, IP66, NEMA 4X, thread NPT1/2										
I		Aluminium housing F34, IP66, NEMA 4X, thread G1/2										
J		Aluminium housing F34, IP66, NEMA 4X, cable gland M20										
P		Polyester housing F14, IP66, NEMA 4, cable gland M20										
Q		Polyester housing F14, IP66, NEMA 4, thread G1/2A										
(3)		Electrical connection										
E5		3-wire, PNP, 10,8 V DC to 45 V DC										
WA		Relay, potential-free change-over contact, 20 AC to 253 V AC, 20 V DC to 55 V DC										
(4)		Additional equipment										
N		without additional equipment										
D		Cover with sight glass										
(5)		Approval										
NA		Version for non-explosion-hazardous area										
CS		CSA, DIP Cl.II, Gr.E-G, Cl.III										
CG		CSA General Purpose										
EX		ATEX II 1/2D Ex ta/tb IIIC T ₂₀₀ 105°C Da/Db										
FS		FM, DIP Cl.II,III, Gr.E-G, T5										

Release date: 2025-01-27 Date of issue: 2025-01-27 Filename: 271947_eng.pdf

Connection

Electronic insert E5

3-wire DC connection

- F: fine-wire fuse, 500 mA
- R: connected load, e. g. PLC, DCS, relay
- M: connection to ground, silo or metal parts silo
- E: grounding

The LCL is protected against reverse polarity. In case of mixing up the connections, the green LED does not illuminate "ready to operate".

PE-connection and PAL-connection for LCL1 are unnecessary.

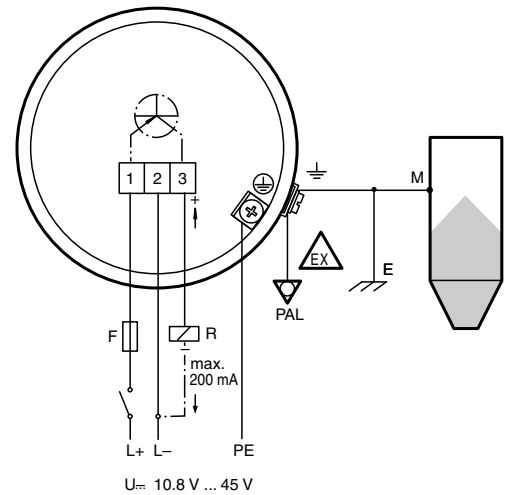

Electronic insert WA

AC/DC connection with relay output

- F1: fine-wire fuse for the protection of the relay contact, dependent on the connected load
- F2: fine-wire fuse, 500 mA
- M: connection to ground, silo or metal parts silo
- E: grounding

PE-connection and PAL-connection for LCL1 are unnecessary.

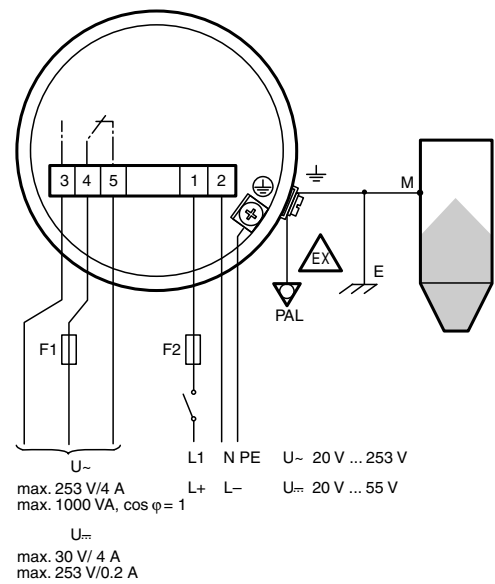

Release date: 2025-01-27 Date of issue: 2025-01-27 Filename: 271947_eng.pdf