

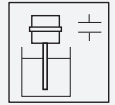

Capacitive limit switch

LCL2



- Limit switch for bulk solids
- Device with rope probe
- Rope probe can be shortened for optimum matching to the measuring point
- Complete unit consisting of the probe and electronic insert
- Integrated active build-up compensation: exact switch point, even with strong build-up
- Mechanically rugged: no wearing parts, long operating life, maintenance-free



Function

The capacitive limit switch is designed for limit detection of light bulk solids, e. g. grain products, flour, milk powder, animal feed, cement, chalk or plaster.

Versions:

- Device with rope probe up to 6 m (20 feet), for bulk solids
- Relay output (potential-free change-over contact) with AC or DC connection
- PNP output with 3-wire DC connection

Connection

Connection type E5, 3-wire DC connection (example)

3-wire DC connection

F: Fine-wire fuse, 500 mA

R: connected load, e. g. PLC, DCS, relay

M: Connection to ground, silo or metal parts silo

E: Grounding

The LCL is protected against reverse polarity. In case of mixing up the connections, the green LED does not illuminate "ready to operate".

PE-connection and PAL-connection for LCL1 are unnecessary.

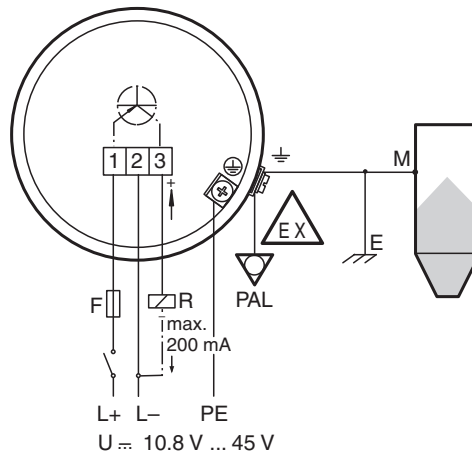

Other connection types see section electrical connection.

Dimensions

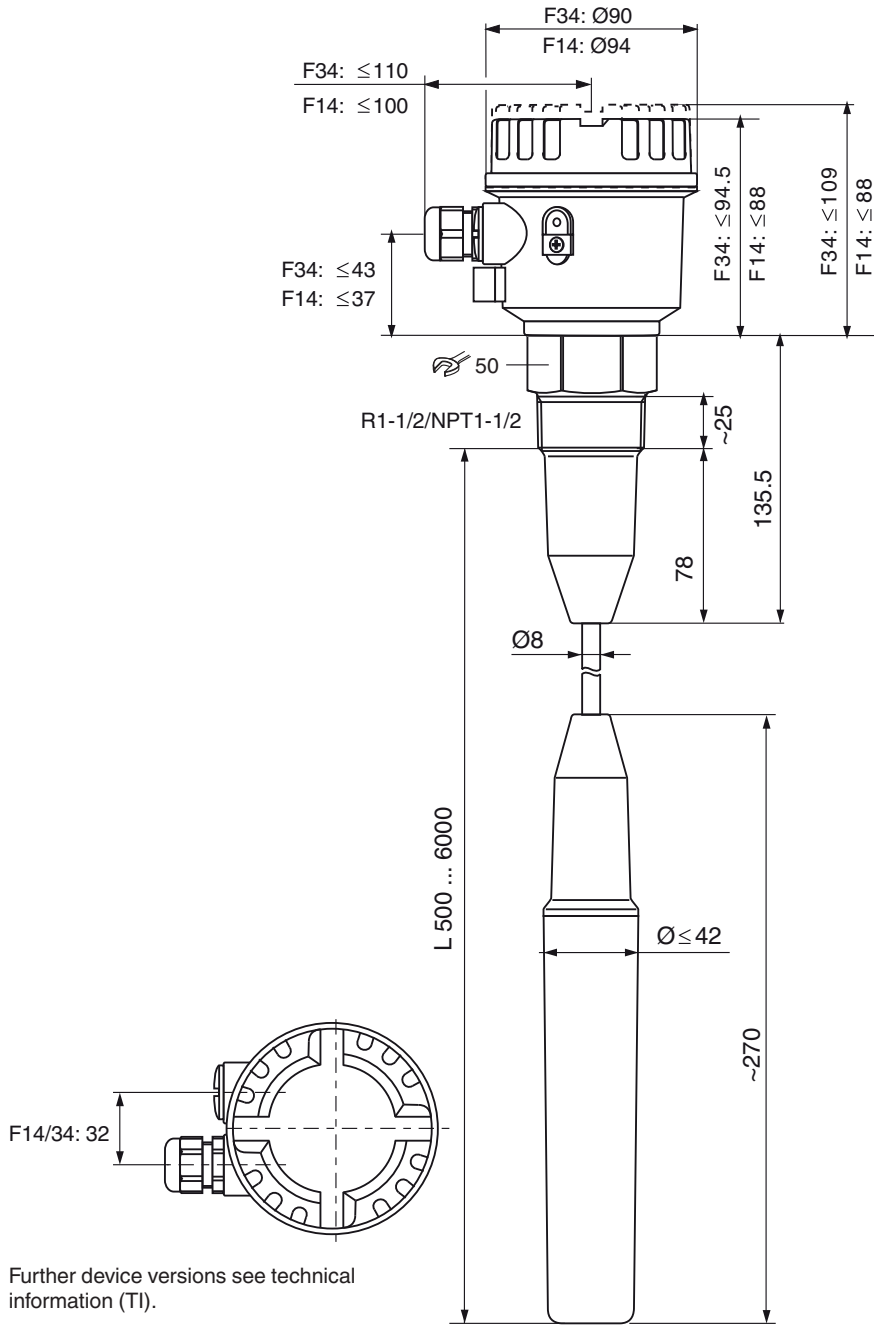

Technical Data

General specifications

Measuring method	A metal plate at the end of the probe, within the insulation, and the surroundings (e. g. the silo walls) combine to form the two electrodes of a capacitor. If the probe is covered or free of material, then the capacitance changes and the LCL switches.
Equipment architecture	The measuring system consists of: - the device - a supply point - the connected control systems, switching units, signalling systems (e. g. lamps, horns, PCS, PLC, etc.)
Construction type	device with rope probe

Release date: 2025-06-30 Date of issue: 2025-06-30 Filename: 271956_eng.pdf

Technical Data

Operating mode		<p>MAX = maximum safety: The device switches if the probe is covered or if the supply voltage is disconnected in a safety-oriented manner (signal on alarm). example application: overspill protection</p> <p>MIN = minimum safety: The device switches if the probe is uncovered or if the supply voltage is disconnected in a safety-oriented manner (signal on alarm). example application: dry-running protection</p>
Series		LCL2
Supply		
Rated voltage	U_r	electrical connection E5: 10.8 ... 45 V DC, short-term pulse on 55 V DC electrical connection WA: 20 ... 235 V AC, 50/60 Hz or 20 ... 55 V DC
Current consumption		electrical connection E5: max. 30 mA, reverse-polarity-proof electrical connection WA: max. 130 mA
Electrical specifications		
Surge protection		overvoltage category III
Input		
Measured variable		limit level (limit value)
Measuring range		dielectric constant ≥ 1.6
Output		
Switch-on delay	t_{on}	correct switching after max. 2 s
Output signal		<p>connection E5: switching PNP, $I_{max} = 200$ mA</p> <ul style="list-style-type: none"> - overload and short circuit protection - residual voltage at transistor at $I_{max} < 2.9$ V <p>connection WA: contact change-over, potential-free</p> <ul style="list-style-type: none"> - $U_{max} = 253$ V - $I_{max} = 4$ A (AC) - $P_{max} = 1000$ VA, $\cos \phi = 1$, $P_{max} = 500$ VA, $\cos \phi > 0.7$
Signal on alarm		connection E5: < 100 μ A connection WA: relay de-energized
Directive conformity		
Electromagnetic compatibility		
Directive 2014/30/EU		EN 61326-1:2006 , EN 61326-2-3:2006
Low voltage		
Directive 2014/35/EU		EN 61010-1:2010
Conformity		
Electromagnetic compatibility		NE 21
Degree of protection		IEC 60529:2001
Vibration resistance		EN 60068-2-64
Climate class		EN 60068, part 2-38 (test Z/AD)
Measurement accuracy		
Reference operating conditions		vessel type: plastic vessel, ambient temperature: 73 °F (23 °C, 296 K), medium temperature: 73 °F (23 °C, 296 K) medium pressure p_e : 0 bar, medium: dielectric constant = 2.6, conductivity: < 1 μ S sensitivity setting: C
Hysteresis		vertical 5 mm (0.2 inch)
Long-term drift		vertical 6 mm (0.24 inch)
Influence of medium temperature		depending on the filling material
Switching time		approx. 0.8 s when covering and uncovering the sensor
Operating conditions		
Installation conditions		
Installation position		vertically down
Mounting location		The capacitive limit switch can be installed in silos made of different materials (e. g. metal, plastic, concrete).
Process conditions		
Process temperature		-40 ... 80 °C (-40 ... 176 °F)
Medium pressure limits		-1 ... 6 bar
State of aggregation		solids
Solid contents		$\leq \varnothing 30$ mm

Technical Data

Bulk density	≤ 200 g/l
Ambient conditions	
Ambient temperature	-40 ... 80 °C (-40 ... 176 °F) -40 ... 60 °C (-40 ... 140 °F) (Dust-Ex version)
Storage temperature	-40 ... 80 °C (-40 ... 176 °F)
Shock resistance	device with F34 housing: 7 J
Vibration resistance	a(RMS) = 50 m/s ² , ASD = 1.25 (m/s ²) ² /Hz, f = 5 to 2000 Hz, t = 3 x 2 h
Mechanical specifications	
Degree of protection	IP66, NEMA 4
Connection	gland M20 thread G1/2, NPT1/2
Material	F14 housing: polyester PBT-FR F34 housing F34: aluminum Probe: PPS GF40 probe rope: PE-HD probe rope seal: VMQ
Dimensions	max. Ø94 mm (3.7 inch), length 140 mm (5.5 inch) + L L = 500 ... 6000 mm (19.7 ... 236 inch)
Process connection	thread R1-1/2 acc. to EN 10226, BSPT thread NPT1-1/2 to ANSI B 1.20.1
Data for application in connection with hazardous areas	
EU-type examination certificate	see instruction manuals (SI)
Directive conformity	
Directive 2014/34/EU	EN 60079-0:2012+A11:2013 , EN 60079-11:2012 , EN 60079-31:2009
General information	
Supplementary documentation	technical information (TI) manuals, brief instructions (BA, KA) instruction manuals (SI)
Supplementary information	Observe the certificates, declarations of conformity, instruction manuals, and manuals where applicable. For information see www.pepperl-fuchs.com .
Accessories	
Designation	- LCL-Z10 cover with sight glass for F14 housing - LCL-Z14 rope shortening set

Type Code

This overview does not mark options which are mutually exclusive.

L	C	L	2	-	(1)	(2)	-	(3)	(4)	(5)	-	(6)
LCL Device												
LCL	Capacitive limit switch											
2 Design												
2	Device with rope probe											
(1) Process connection												
Threads												
N5	NPT1-1/2, ANSI, PPS											
R5	R1-1/2, EN 10226, PPS											
(2) Probe length												
3	1500 mm (59 inch), steel, HD-PE insulated											
4	2500 mm (98 inch), steel, HD-PE insulated											
5	4000 mm (157 inch), steel, HD-PE insulated											
6	6000 mm (236 inch), steel, HD-PE insulated											
I	Specified length in inch, steel, HD-PE insulated, max. 236 inch											
X	Specified length in mm, steel, HD-PE insulated, max. 6000 mm											
(3) Housing												
C	Polyester housing F14, IP66, NEMA 4, thread NPT1/2											
H	Aluminium housing F34, IP66, NEMA 4X, thread NPT1/2											
I	Aluminium housing F34, IP66, NEMA 4X, thread G1/2											
J	Aluminium housing F34, IP66, NEMA 4X, cable gland M20											
P	Polyester housing F14, IP66, NEMA 4, cable gland M20											

Release date: 2025-06-30 Date of issue: 2025-06-30 Filename: 271956_eng.pdf

Type Code

(3) Housing	
Q	Polyester housing F14, IP66, NEMA 4, thread G1/2A
(4) Electrical connection	
E5	3-wire, PNP, 10,8 V DC to 45 V DC
WA	Relay, potential-free change-over contact, 20 AC to 253 V AC, 20 V DC to 55 V DC
(5) Additional equipment	
N	without additional equipment
D	Cover with sight glass
(6) Approval	
NA	Version for non-explosion-hazardous area
CS	CSA, DIP Cl.II, Gr.E-G, Cl.III
CG	CSA General Purpose
EX	ATEX II 1/2D Ex ia/tb [ia Da] IIIC T ₂₀₀ T108°C T91°C Da/Db
FS	FM, DIP Cl.II,III, Gr.E-G, T5

Connection

Electronic insert E5

3-wire DC connection

- F: fine-wire fuse, 500 mA
- R: connected load, e. g. PLC, DCS, relay
- M: connection to ground, silo or metal parts silo
- E: grounding

The LCL is protected against reverse polarity. In case of mixing up the connections, the green LED does not illuminate "ready to operate".

PE-connection and PAL-connection for LCL1 are unnecessary.

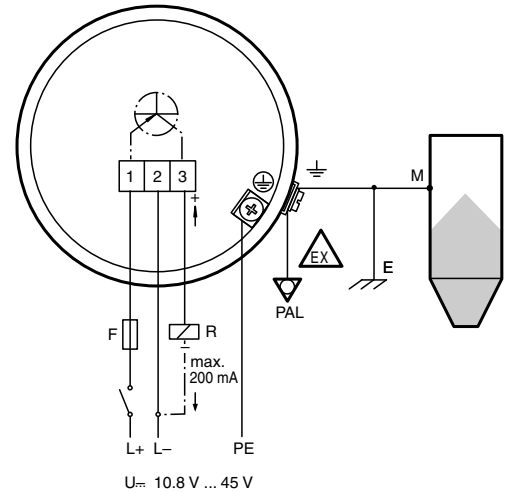

Electronic insert WA

AC/DC connection with relay output

- F1: fine-wire fuse for the protection of the relay contact, dependent on the connected load
- F2: fine-wire fuse, 500 mA
- M: connection to ground, silo or metal parts silo
- E: grounding

PE-connection and PAL-connection for LCL1 are unnecessary.

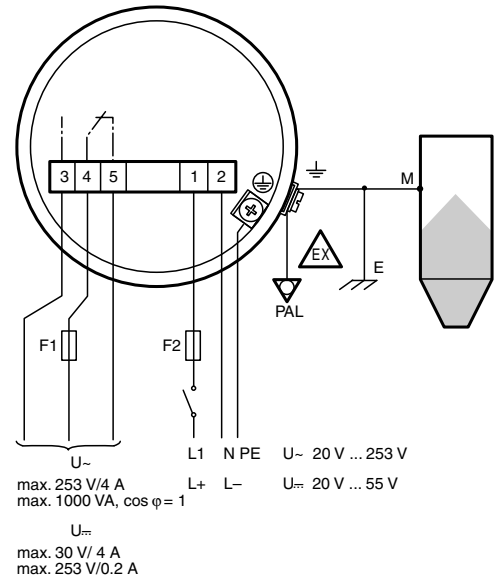

Release date: 2025-06-30 Date of issue: 2025-06-30 Filename: 271956_eng.pdf