

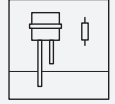

Conductive Limit Switch

LKL-P1



- Limit switch for conductive liquids
- Device with rod probe
- Detect up to five level limits with one probe
- Flexible instrumentation
- No moving parts in the tank
- No calibration: quick and low-cost start up
- Two-point control and additional maximum and minimum detection
- Approval as overflow protection and leak detection system acc. to WHG



Function

The device is used in conductive liquids (as of 10 $\mu\text{s}/\text{cm}$) for determining level limits. Depending on the number of measuring points (up to 5 rods or ropes), measuring tasks such as overspill protection, dry running protection, two-point control of pumps or multiple point detection can be implemented for an existing process connection.

- Flexible instrumentation: with built-in electronic insert, either transistor or relay output for 2 or 3 rod probes and for connection to a separate transmitter power supply unit
- No calibration required: standard setting for the most common conductive liquids
- No moving parts in the tank: long service life and reliable operation with no wear or blockages

Connection

Example:

Output WA (FEW54), compact instrument version, AC/DC connection with relay output

Relay contact circuit for load

The connected load is switched via potential-free relay contacts (change-over contact).

In the event of a level alarm or a power failure, the relay contacts break the connections between terminals 3 and 4 and terminals 6 and 7. The relays always switch simultaneously.

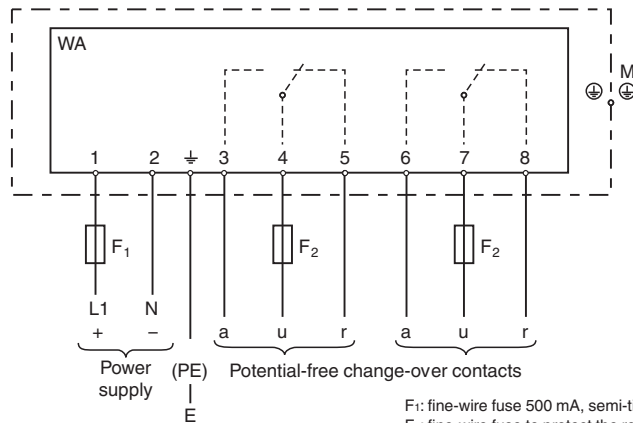

- F1: fine-wire fuse 500 mA, semi-time lag
- F2: fine-wire fuse to protect the relay contact, load-dependent
- M: ground connection to protective earth (PE)
- E: grounding (functional earth optional)

Other connection types see section electrical connection.

Release date: 2025-01-27 Date of issue: 2025-01-27 Filename: 272170_eng.pdf

Dimensions

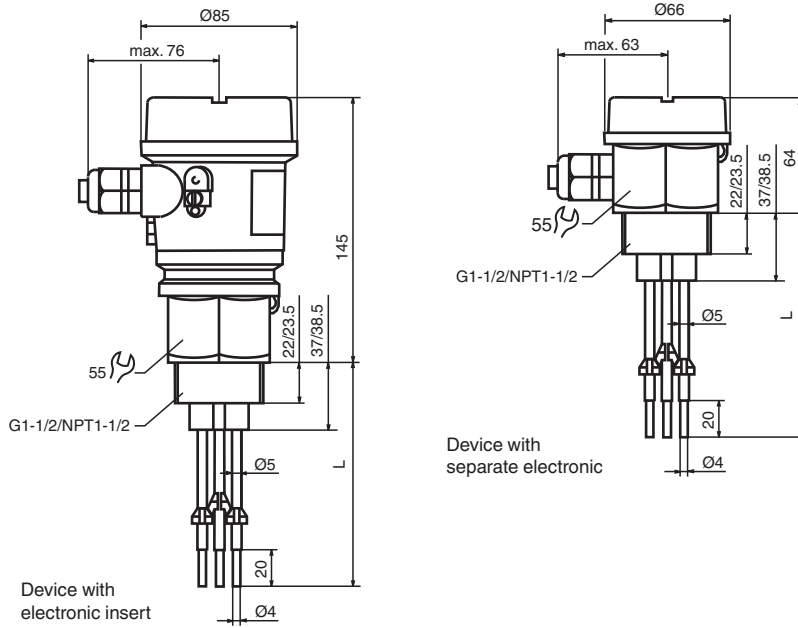

Technical Data

General specifications

Type	sensor for conductive limit value detection
Measuring method	An alternating voltage exists between the probes in an empty tank. As soon as the conductive liquid in the tank creates a connection between the ground probe and, for example, the maximum probe, a measurable current flows and the device switches. With level limit detection, the device switches back as soon as the liquid clears the maximum probe. With two-point control, the device does not switch back until the max and min probe is cleared. Using alternating voltage prevents corrosion of the probes and electrolytic destruction of the product. The material used for the tank walls is not important for measurement because the system is designed as a closed potential-free circuit between the probes and the electronics. There is absolutely no danger if the probes are touched during operation.
Construction type	device with rod probe
Operating mode	Selecting the correct fail-safe mode ensures that the relay/the output always runs in quiescent current fail-safe. output E5 (FEW52): - maximum fail-safe: The output signal is < 1 mA if the switch point is exceeded (probe covered), a fault occurs or the power supply fails. - minimum fail-safe: The output signal is < 1 mA if the switch point is undershot (probe uncovered), a fault occurs or the power supply fails. Output WA (FEW54): - maximum fail-safe: The relay de-energises when the switch point is exceeded (probe covered), a fault occurs or the power supply fails. - minimum fail-safe: The relay de-energizes when the switch point is undershot (probe uncovered), a fault occurs or the power supply fails. output N1 (FEW58): - maximum fail-safe: The output voltage is 0 V if the switch point is exceeded (probe covered), a fault occurs or the power supply fails. - minimum fail-safe: The output voltage is 0 V if the switch point is undershot (probe uncovered), a fault occurs or the power supply fails.
Series	LKL-P1
Versions	probe with integrated electronic insert (compact instrument version) probe without integrated electronic insert (separate instrument version) for one, two or multiple point detection respectively, see section measuring system
Supply	
Connection	see section electrical connection

Release date: 2025-01-27 Date of issue: 2025-01-27 Filename: 272170_eng.pdf

Technical Data

Rated voltage	U_r	Output E5 (FEW52): supply voltage 10.8 ... 45 V DC load connection: open collector; PNP switching voltage: max. 45 V output WA (FEW54): supply voltage 20 ... 55 V DC or 20 ... 253 V AC, 50/60 Hz peak inrush current: max. 2 A, max. 400 μ s output: two potential-free change-over contacts output N1 (FEW58): refer to datasheet of the connected switch amplifier acc. to IEC 60947-5-6 (NAMUR)
Current consumption		Output E5 (FEW52): $I < 25$ mA (without load) output WA (FEW54): 60 mA
Power consumption		Output E5 (FEW52): $P < 1.1$ W output WA (FEW54): $P < 2.0$ W
Reverse polarity protection		output E5 (FEW52)
Contact loading		output WA (FEW54): 253 V AC/4 A, 30 V DC/4 A, 150 V/0.2 A
Input		
Connection		see section electrical connection
Input signal		probes covered - A measurable current is flowing between the probes. probes uncovered - There is no measurable current flowing between the probes.
Measured variable		resistance change between two conductors caused by the presence or absence of a conductive product.
Measuring range		The measuring range depends on the mounting location of the device 250 ... 4000 mm
Output		
Connection		see section electrical connection
Switching delay		A switching delay of 2.0 s can be activated or deactivated via a DIL switch. If the switching delay is set to 0 s, the device switches after approx. 0.3 s.
Load		Output E5 (FEW52): The load is switched via a transistor (PNP), cycled overload and short-circuit protection, continuous ≤ 200 mA (short-circuit proof), residual voltage at transistor at I_{max} 2.9 V Output WA (FEW54): Loads are switched via 2 potential-free change-over contacts. $I \sim$ max. 4 A, $U \sim$ max. 253 V $P \sim$ max. 1000 VA, $\cos \phi = 1$, $P \sim$ max. 700 VA, $\cos \phi > 0.7$ $I \sim$ max. 4 A to 30 V, $I \sim$ max. 0.2 A to 150 V When connecting a functional extra-low voltage circuit with double insulation in accordance with IEC 1010: The sum of the relay output and power supply voltages is max. 300 V. output N1 (FEW58): refer to datasheet of the connected switch amplifier acc. to IEC 60947-5-6 (NAMUR)
Measuring range		A total of four measuring ranges (100 Ω , 1 k Ω , 10 k Ω , 100 k Ω) can be set via two DIL switches (SENS). The setting on delivery is 100 k Ω .
Output signal		see section electrical connection
Signal on alarm		Output E5 (FEW52): in the event of a power failure or a damaged probe: < 100 μ A. output WA (FEW54): output signal in the event of a power failure or a damaged probe: relay de-energised. output N1 (FEW58): output signal with damaged sensor < 1 mA
Galvanic isolation		
Input/Other circuits		output WA (FEW54): All input channels, output channels and relay contacts are galvanically isolated from each other.
Directive conformity		
Electromagnetic compatibility		
Directive 2014/30/EU		EN 61326-1:2006 , EN 61326-2-3:2006
Low voltage		
Directive 2014/35/EU		EN 61010-1:2001
Conformity		
Electromagnetic compatibility		
		NE 21
Degree of protection		
		IEC 60529:2001
Vibration resistance		
		EN 60068-2-64
Climate class		
		DIN EN 60068-2-38/IEC 68-2-38
Measurement accuracy		
Reference operating conditions		ambient temperature: 23 $^{\circ}$ C (296 K), medium temperature: 23 $^{\circ}$ C (296 K), medium viscosity: medium must release the probe again (drain off), medium pressure pe: 0 bar, probe installation: vertically from above

Technical Data

Maximum measured error	$\pm 10\%$ at 0.1 ... 100 k Ω $\pm 5\%$ at 1 ... 10 k Ω
Non-repeatability	$\pm 5\%$ at 0.1 ... 100 k Ω $\pm 1\%$ at 1 ... 10 k Ω
Hysteresis	-10 % for the max probe, in reference to the switch point, Δs function deactivated
Influence of ambient temperature	< 0.05 %/K
Switching time	< 3 s
Operating conditions	
Installation conditions	
Mounting location	mounting in tanks made of plastic or metal
Process conditions	
Medium temperature	-40 ... 100 °C (-40 ... 212 °F)
Medium pressure	-1 ... 10 bar (-14.5 ... 145 psi)
Conductivity	$\geq 10\ \mu\text{S}$
Ambient conditions	
Ambient temperature	-40 ... 70 °C (-40 ... 158 °F) -40 ... 60 °C (233 ... 333 K) for output N1 (FEW58)
Storage temperature	-40 ... 80 °C (-40 ... 176 °F)
Climatic conditions	tropicalized
Vibration resistance	20 ... 2000 Hz, 1 (m/s ²)/Hz
Impact resistance	practical test
Mechanical specifications	
Degree of protection	IP66
Connection	cable connection M20x1.5, 1/2NPT, G1/2
Material	rod probes: 1.4404/316L, insulation: PP housing: - output NA (separate instrument version): housing PPS, cover PBT - output E5/WA/N1 (compact instrument version): housing PBT, cover PBT, adapter PBT process connections: PPS
Mass	separate instrument version: with probe length 1 m (3 ft), with 2, 3 or 5 rods: 415 g, 530 g, 760 g compact instrument version: with probe length 1 m (3 foot), with 2 or 3 rods: 600 g, 720 g
Dimensions	housing: max. $\varnothing 85$ mm (3.3 inch), height max. 145 mm (5.7 inch) rod probes: compact instrument version 2 or 3 rods, separate instrument version 2, 3 or 5 rods - diameter without insulation: $\varnothing 4$ mm (0.16 inch) - rod length: 100 ... 4000 mm (4 in ... 13 ft) - thickness of insulation: 0.5 mm (0.02 inch) - length of non-insulated area (tip of rod): 20 mm (0.8 inch) - extraction forces: 1000 N
Process connection	- thread G1-1/2 acc. to DIN/ISO 228/1 - thread NPT1-1/2 acc. to ANSI B 1.20.1
Data for application in connection with hazardous areas	
EU-type examination certificate	TÜV 03 ATEX 2295
Marking	Ⓔ II 2G Ex ia/ib IIB/IIC T6...T5 Gb
Certificate	Pepperl+Fuchs
Marking	Ⓔ II 3G Ex nA/nC (L) IIC T6
Directive conformity	
Directive 2014/34/EU	EN 60079-0:2009 , EN 60079-11:2007
Indication and operation	
Display elements	separate instrument version: dependent on the connected switching unit compact instrument version: output E5 (FEW52), WA (FEW54): - one red light emitting diode: fault message, switching status - one green light emitting diode: operation output N1 (FEW58): - one yellow light emitting diode: fault message, switching status - one green light emitting diode: operation
Control elements	- one DIL switch for min/max position - one DIL switch for 0 s or 2 s switching delay - two DIL switches for setting the measuring ranges 100 Ω , 1 k Ω , 10 k Ω , 100 k Ω

Technical Data

Certificates and approvals

Overspill protection	Z-65.13-378 (overspill protection acc. to WHG) Z-65.40-379 (leak detection system acc. to WHG) see approval (ZE)
----------------------	--

General information

Supplementary documentation	technical information (TI) brief instructions (KA) approval (ZE)
Supplementary information	Observe the certificates, declarations of conformity, instruction manuals, and manuals where applicable. For information see www.pepperl-fuchs.com .

Accessories

Designation	- LKL-Z10 lock nut G1-1/2, AF60 - LZ-1204 mounting bracket G1-1/2 - electronic insert E5 (FEW52), output PNP 10.8 V DC ... 45 V DC - electronic insert WA (FEW54), output relay 20 V AC ... 253 V AC, 20 V DC ... 55 V DC - electronic insert N1 (FEW58), output NAMUR (IEC 60947-5-6)
-------------	--

Type Code

This overview does not mark options which are mutually exclusive.

L	K	L	-	P	1	-	(1)	(2)	(3)	-	(4)	(5)	(6)	-	(7)	.	L
---	---	---	---	---	---	---	-----	-----	-----	---	-----	-----	-----	---	-----	---	---

LKL-P	Device
LKL-P	Conductive limit switch

1	Design
1	Device with rod probe

(1)	Process connection
G5	Thread G1-1/2, DIN/ISO 228/1, plastic PPS
N5	Thread NPT1-1/2, ANSI, plastic PPS

(2)	Quantity and rod type
2	2 rods, stainless steel 1.4404/316L
3	3 rods, stainless steel 1.4404/316L
5	5 rods, stainless steel 1.4404/316L

(3)	Probe length
A	Specified length L in mm, 100 mm to 4000 mm
B	Specified length L in inch, 3.9 inch to 157.5 inch
C	1000 mm
D	2000 mm

(4)	Housing
P1	Plastic housing, IP66, M20x1,5
P2	Plastic housing, IP66, NPT1/2
P3	Plastic housing, IP66, G1/2

(5)	Electrical output
E5	FEW52, PNP, 10.8 V to 45 V DC
N1	FEW58, NAMUR
NA	Separate instrumentation (without electronic insert)
WA	FEW54, relay, 20 V to 253 V AC
XX	Electronics retrofittable

(6)	Additional equipment
N	without additional equipment
Y	Special version

(7)	Approval
NA	Version for non-explosion-hazardous area
EB	ATEX II 2 G Ex ia IIC T5 Gb ATEX II 2 G Ex ia [ia] IIC T6 Gb
WH	WHG overfill protection

Connection

Output WA (FEW54) compact instrument version

Relay contact circuit for load:
The connected load is switched via potential-free relay contacts (change-over contact).

In the event of a level alarm or a power failure, the relay contacts break the connections between terminals 3 and 4 and terminals 6 and 7. The relays always switch simultaneously

Protection against voltage peaks and short-circuits:

When connecting a device with high inductance, fit a spark barrier to protect the relay contact. A fine-wire fuse (load-dependent) can protect the relay contact in the event of a short-circuit.

Output signal:

When connecting a device with high inductance, a spark barrier must be fitted to protect the relay contact. A fine-wire fuse (load-dependent) protects the relay contact in the event of a short-circuit. Both relay contacts switch simultaneously.

If the probe is covered and the red LED flashes continuously, the next more sensitive measuring range has to be set. This ensures a safe switch point even if the conductivity of the medium varies slightly.

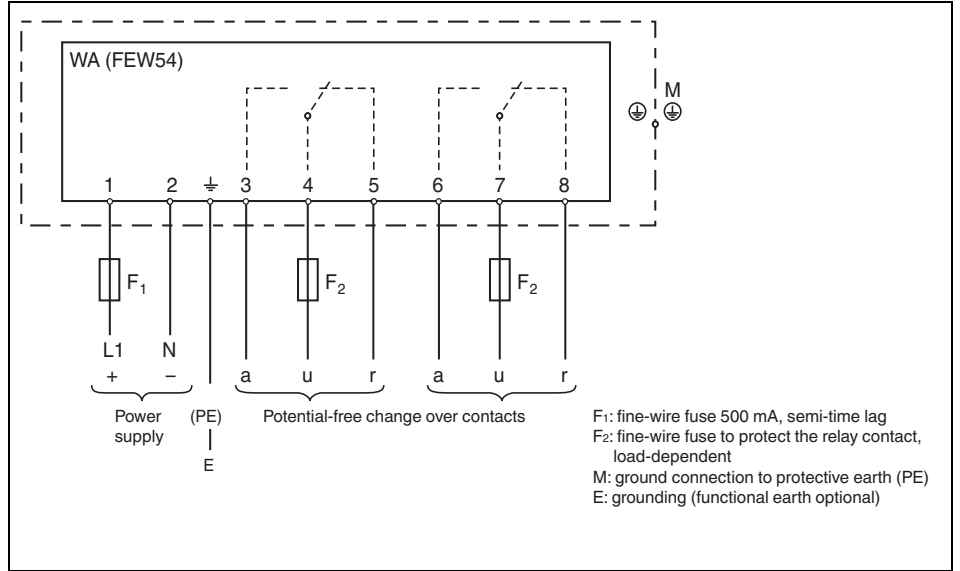

Fail safe mode	Switch point	Output signal	rd
Max. 		*1 3 4 5 6 7 8	*3
		*2 3 4 5 6 7 8	*4
Min. 		*1 3 4 5 6 7 8	
		*2 3 4 5 6 7 8	

*1 = load current (connected); *2 residual current (disconnected); *3 LED not lit; *4 LED lit

Output E5 (FEW52) compact instrument version

Transistor circuit for load:

The load connected to terminal 3 is switched by a transistor, contactless and therefore without bouncing.

In normal switching status, terminal 3 has a positive signal. The transistor is blocked in the event of a level alarm or a power failure.

Protection against voltage peaks:

When connecting a device with high inductance, always connect a voltage limiter.

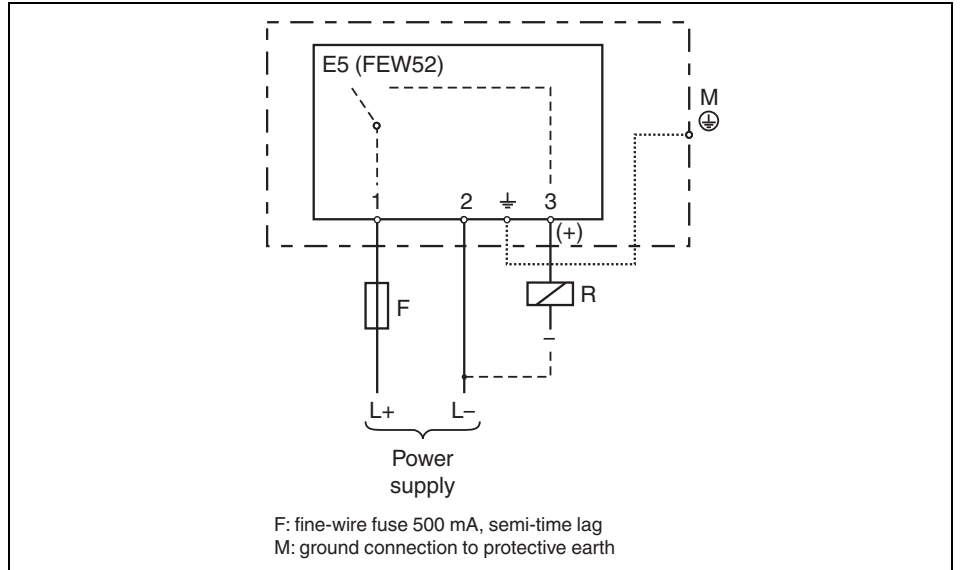

Output signal:

Preferred in conjunction with programmable logic controllers (PLC). Positive signal at the switch output of the electronics (PNP). The output is blocked after the level limit is reached.

If the probe is covered and the red LED flashes continuously, the next more sensitive measuring range has to be set. This ensures a safe switch point even if the conductivity of the medium varies slightly.

Fail safe mode	Switch point	Output signal	rd
Max. 		*1 L+ → I _L → 3	*3 ●
		*2 1 → < 100 μA → 3	*4 ☀
Min. 		L+ → I _L → 3	●
		+ → < 100 μA → 3	☀

*1 = load current (connected); *2 residual current (disconnected); *3 LED not lit; *4 LED lit

Output N1 (FEW58) compact instrument version

To be used with isolating amplifiers acc. to NAMUR (IEC 60947-5-6):
 Output signal jump from high to low current on limit (H-L edge).
 Signal transmission on a two-wire line: H-L edge 2.2 mA ... 6.5 mA / 0.4 mA ... 1.0 mA
 When using a multiplex the cycle time must be set to a minimum of 2 s.

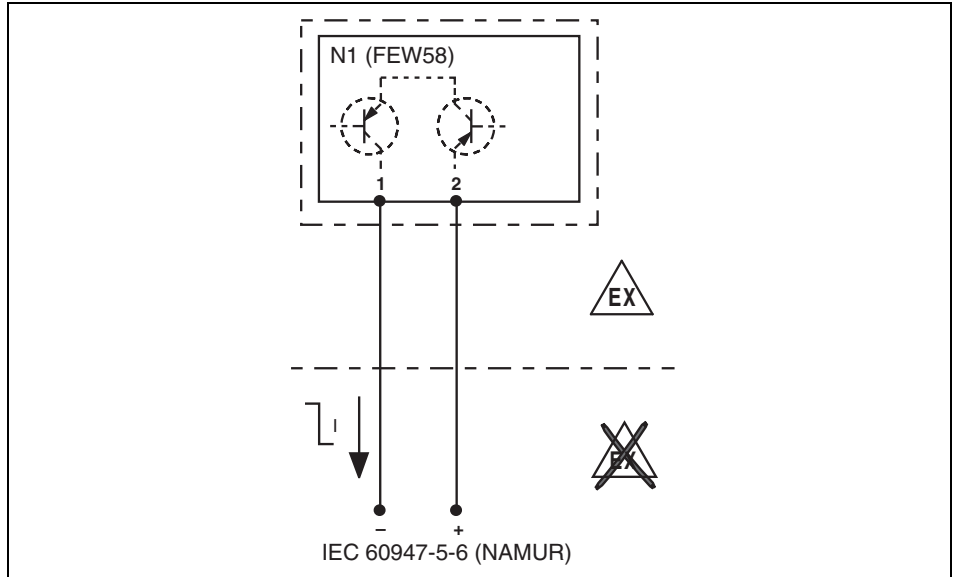

Output signal:
 For connecting to isolating amplifiers acc. to NAMUR (IEC 60947-5-6)

Fail-safe mode	Level	Output signal	LEDs	
			green	yellow
Max.		+ 2.2 mA ... 6.5 mA 2 → 1		
		+ 0.4 mA ... 1.0 mA 2 → 1		
Min.		+ 2.2 mA ... 6.5 mA 2 → 1		
		+ 0.4 mA ... 1.0 mA 2 → 1		

= lit = flashes = unlit

Output NA separate instrument version

Separate instrumentation for 2 rod probes with cable monitoring

*1 Printed circuit board for cable monitoring
The power supply and evaluation are provided by switching units.

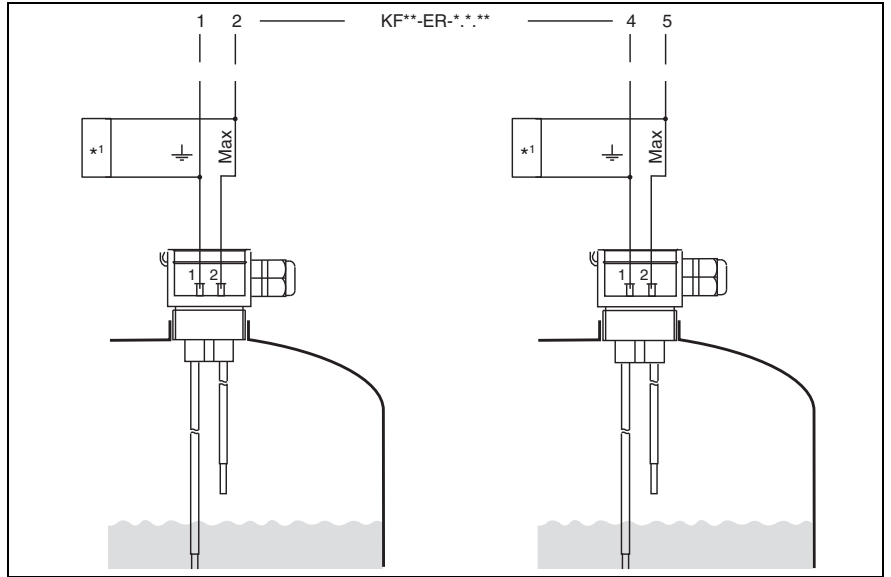

Separate instrumentation for 3 rod probes with cable monitoring

*1 Printed circuit board for cable monitoring
The power supply and evaluation are provided by switching units.

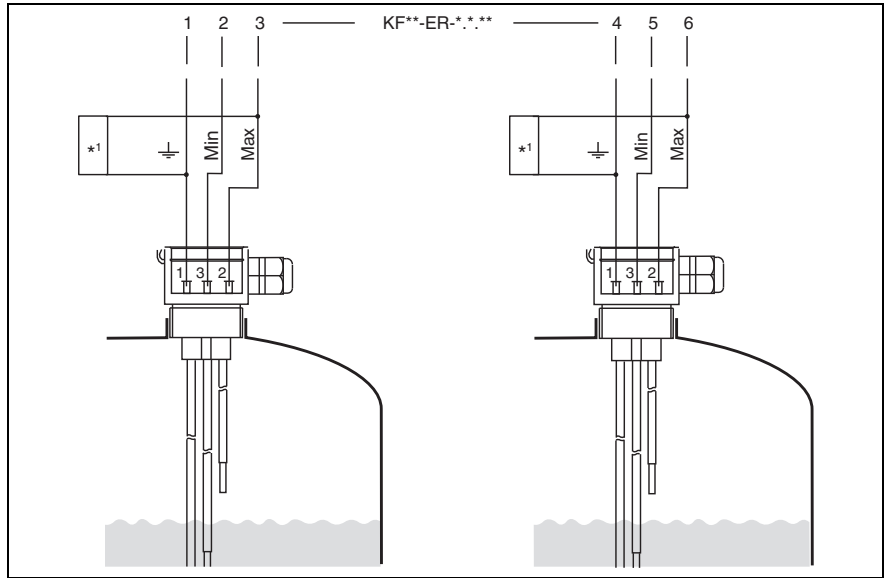

Separate instrumentation for 5 rod probes with cable monitoring

*1 Printed circuit board for cable monitoring
The power supply and evaluation are provided by switching units.

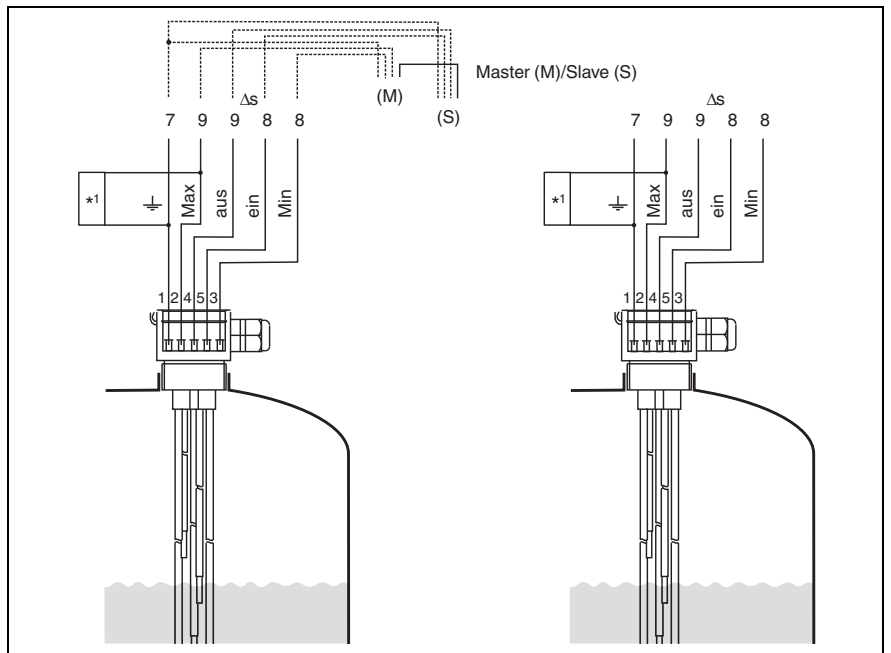

Release date: 2025-01-27 Date of issue: 2025-01-27 Filename: 272170_eng.pdf

Application

Application examples

Level limit detection: two-point control (Δs)

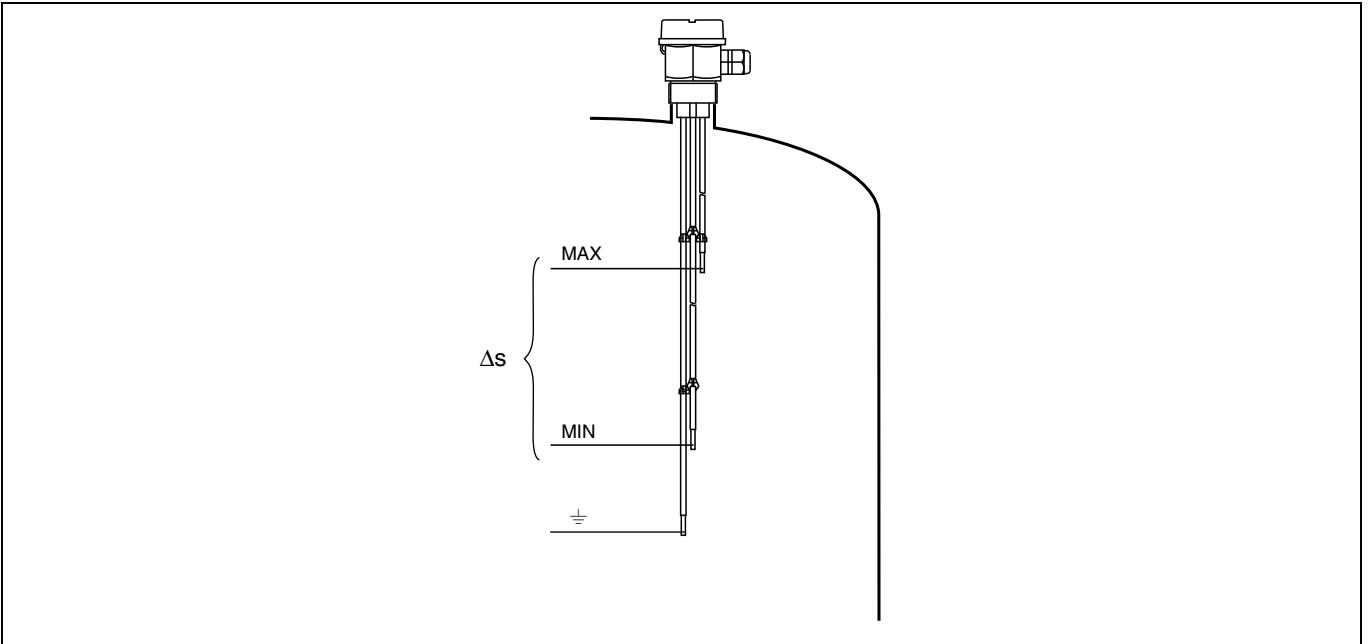

Two-point control (Δs) e. g. pump control

Level limit detection: MAX and MIN detection

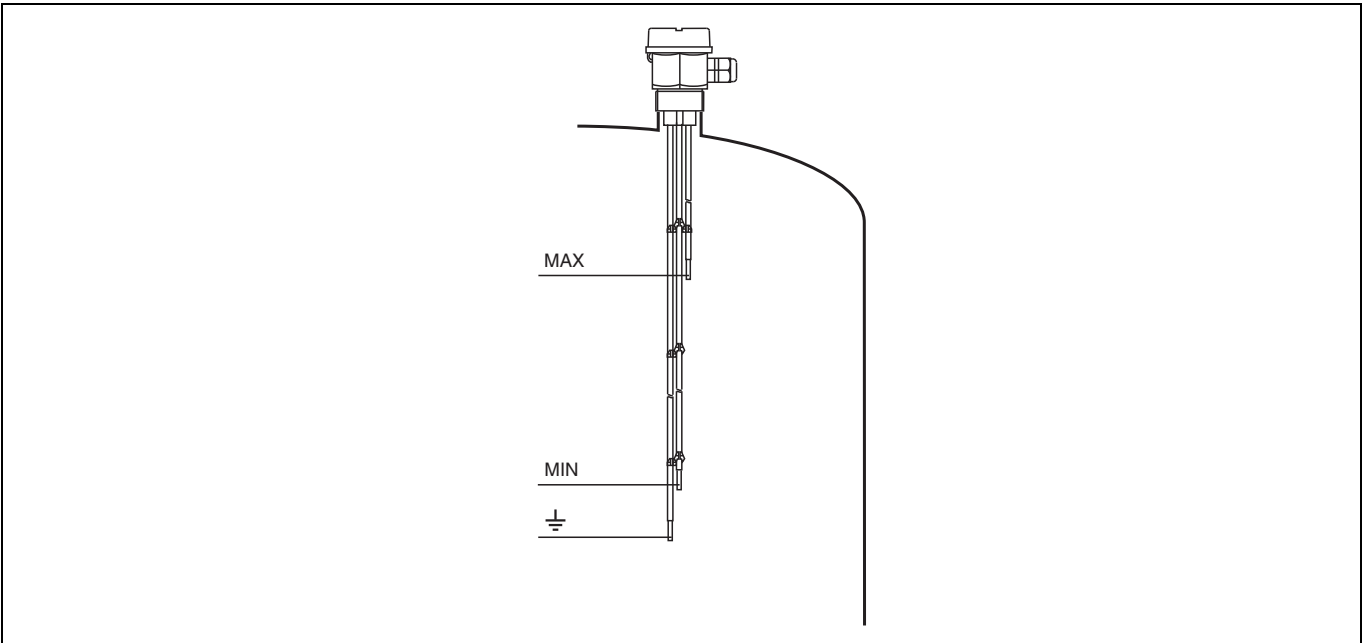

Level limit detection (MAX)

MAX and MIN detection for compact instrumentation version only possible with Δs .

Release date: 2025-01-27 Date of issue: 2025-01-27 Filename: 272170_eng.pdf