

# Vibration Limit Switch

## Vibracon

### LVL-B1

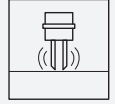

- Limit switch for bulk solids
- Compact device
- No calibration: easy commissioning (plug and play)
- Insensitive to build-up: maintenance-free operation
- No mechanically moving parts: no wear, long operating life
- Sensor material stainless steel: hardly any abrasion even with building materials
- Insensitive to external vibration and flow noises



## Function

The device is a robust level limit switch for silos with fine-grained or coarse-grained, non-fluidised bulk solids. The various designs means the device has a wide range of applications. Certificates are also available for use in dust incensive hazard areas. Typical applications: cereals, coffee beans, sugar, animal feed, rice, detergents, dye powder, chalk, gypsum, cement, sand, plastic granules

## Connection

### Connection FEM 22 (E5) 3-wire DC connection (example)

- preferably for use with memory programmable controls (PLC), DI modules as per EN 61131-2
- positive signal at the electronics switch output (PNP)
- Output blocked at level limit.

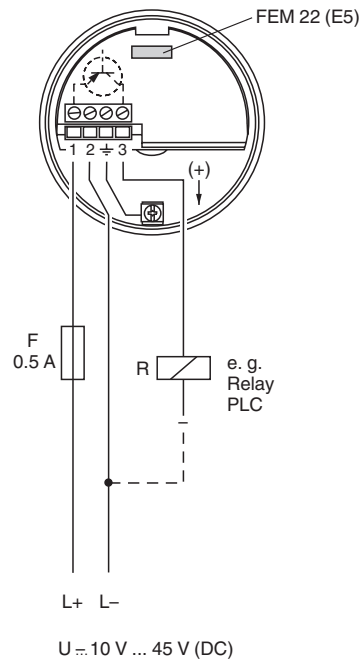

Other connection types see section electrical connection.

## Dimensions

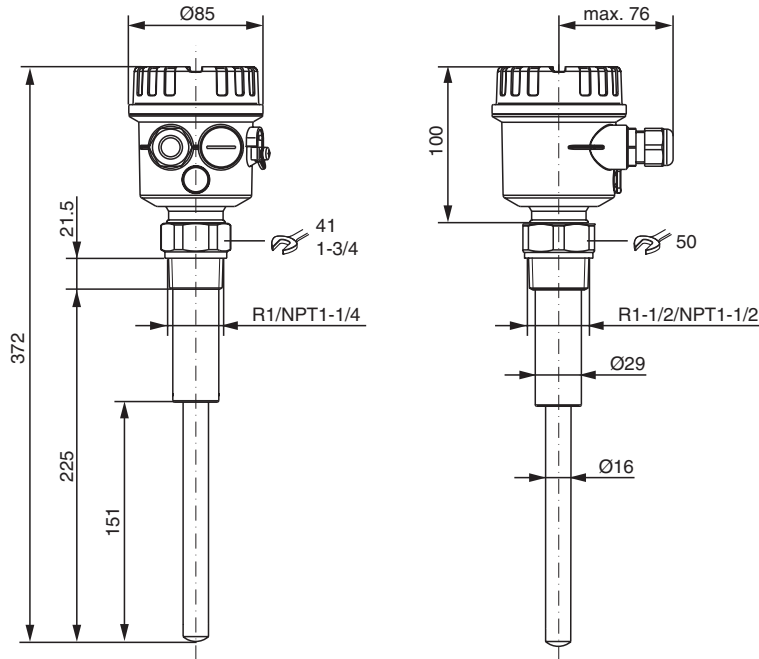

## Technical Data

General specifications	
Measuring method	A piezoelectric drive excites the vibrating rod of the device to its resonance frequency. If medium covers the vibrating rod, the rod's vibrating amplitude changes (the vibration is damped). The electronics of the device compare the actual amplitude with a target value and indicates whether the vibrating rod is vibrating freely or whether it is covered by medium.
Equipment architecture	The measuring system consists of: - the device with electronic insert - a supply point - the connected control systems, switching units, signalling systems (e. g. lamps, horns, PCS, PLC, etc.)
Construction type	compact device
Operating mode	MAX = maximum safety: The device switches if the probe is covered or if the supply voltage is disconnected in a safety-oriented manner (signal on alarm). example application: overspill protection MIN = minimum safety: The device switches if the probe is uncovered or if the supply voltage is disconnected in a safety-oriented manner (signal on alarm). example application: dry-running protection
Series	Vibracon LVL-B1
Supply	
Rated voltage	$U_r$ electronic insert FEM22 (E5): 10 ... 45 V DC electronic insert FEM24 (WA): 19 ... 253 V AC, 50/60 Hz or 19 ... 55 V DC
Ripple	electronic insert FEM22 (E5): max. 5 V, 0 ... 400 Hz
Current consumption	electronic insert FEM22 (E5): max. 18 mA
Power consumption	electronic insert FEM22 (E5): max. 0.81 W electronic insert FEM 24 (WA): max. 1.3 W
Reverse polarity protection	separation voltage 2.2 kV
Electrical specifications	
Surge protection	electronic insert FEM22 (E5) : overvoltage category III
Input	
Input signal	probe covered - small amplitude probe not covered - large amplitude
Measured variable	level (according to the mounting location and the overall length)

## Technical Data

Measurement range	The measuring range depends on the mounting location of the device	
<b>Output</b>		
Load	electronic insert FEM22 (E5): - load switched via transistor and separate PNP connection - load current: max. 45 V (cyclical overload and short-circuit protection), continuous max. 350 mA - residual current: < 100 µA (for blocked transistor) - capacitive load: max. 0.5 µF for 45 V, max. 1.0 µF for 24 V - residual voltage: < 3 V (for transistor switched through) electronic insert FEM24 (WA): - loads switched via 2 floating change-over contacts - version AC: I max. 6 A, U max. 253 V; P max. 1500 VA, $\cos \phi = 1$ , P max. 750 VA, $\cos \phi > 0.7$ - version DC: I max. 6 A to 30 V, I max. 0.2 A to 125 V - the following applies when connecting a functional extra-low voltage circuit with double insulation as per IEC 1010: sum of voltages of relay output and power supply max. 300 V	
Switch-on delay	$t_{on}$	correct switching after max. 3 s
Output signal	digital	
Signal on alarm	electronic insert FEM22 (E5): output signal on power failure or in the event of device failure - < 100 µA electronic insert FEM24 (WA): output signal in event of power failure - relay de-energised	
<b>Galvanic isolation</b>		
Input/power supply	electronic insert FEM22 (E5)	
Input/Other circuits	electronic insert FEM24 (WA)	
<b>Directive conformity</b>		
Electromagnetic compatibility		
Directive 2014/30/EU	EN 61326-1:2006 , EN 61326-2-3:2006	
Low voltage		
Directive 2014/35/EU	electronic insert FEM24 (WA) : EN 61010-1:2010	
<b>Conformity</b>		
Electromagnetic compatibility	NE 21	
Degree of protection	IEC 60529:2001	
Vibration resistance	EN 60068-2-27	
Climate class	EN 60068, part 2-38, fig. 2a	
<b>Measurement accuracy</b>		
Measuring frequency	700 ... 800 Hz	
Switching time	when covering the sensor approx. 0.5 s, when uncovering the sensor approx. 1.0 s	
<b>Operating conditions</b>		
Installation conditions		
Installation position	see section mounting position	
Process conditions		
Process temperature	-40 ... 150 °C (-40 ... 302 °F)	
Medium pressure limits	-1 ... 25 bar max. working pressure 25 bar, burst pressure 100 bar	
Thermal shock resistance	max. 120 K	
State of aggregation	solids	
Solid contents	≤ Ø25 mm	
Bulk density	≥ 200 g/l, not fluidised	
<b>Ambient conditions</b>		
Ambient temperature	-40 ... 70 °C (-40 ... 158 °F)	
Storage temperature	-40 ... 85 °C (-40 ... 185 °F)	
<b>Mechanical specifications</b>		
Degree of protection	IP66/IP67, NEMA 4X	
Connection	gland M20 thread G1/2, NPT1/2	
Material	F16 housing: PTB-FR, cover with transparent glass made of PA12, EPDM cover seal F18 housing: aluminum EN-AC-AISi10Mg, plastic coated cover seal: EPDM process connections, sensor: stainless steel 1.4435/316L	

## Technical Data

Mass	device with F16 housing, electronic insert FEM24 (WA) and R1 thread: approx. 1.0 kg
Dimensions	max. Ø85 mm (3.3 inch), length 372 mm (14.6 inch)
Process connection	thread R1, R1-1/2 acc. to DIN 2999 thread 1-1/4 - 11-1/2 NPT, 1-1/2 - 11-1/2 NPT acc. to ANSI B 1.20.1
<b>Data for application in connection with hazardous areas</b>	
EU-type examination certificate	see instruction manuals
<b>International approvals</b>	
IECEX approval	see instruction manuals
<b>General information</b>	
Supplementary documentation	technical information (TI) manuals, brief instructions (BA, KA) instruction manuals
Supplementary information	Observe the certificates, declarations of conformity, instruction manuals, and manuals where applicable. For information see <a href="http://www.pepperl-fuchs.com">www.pepperl-fuchs.com</a> .

## Type Code

This overview does not mark options which are mutually exclusive.

L	V	L	-	B	1	-	(1)	-	(2)	(3)	A	-	(4)
<b>LVL</b>	<b>Device</b>												
LVL	Vibration limit switch												
<b>B1</b>	<b>Design</b>												
B1	Compact device												
<b>(1)</b>	<b>Process connection</b>												
Thread													
N3	NPT1-1/4, ANSI, 1.4435/316L												
N5	NPT1-1/2, ANSI, 1.4435/316L												
R3	R1, DIN 2999, 1.4435/316L												
R5	R1-1/2, DIN 2999, 1.4435/316L												
XX	Special version												
<b>(2)</b>	<b>Housing, cable entrance</b>												
A6	Aluminium housing F18, IP66/IP67, NEMA 4X, cable gland M20												
A7	Aluminium housing F18, IP66/IP67, NEMA 4X, thread NPT3/4												
A8	Aluminium housing F18, IP66/IP67, NEMA 4X, thread G1/2												
C2	Polyester housing F16, IP66/IP67, NEMA 4X, cable gland M20												
P4	Polyester housing F16, IP66/IP67, NEMA 4X, thread G1/2A												
Q3	Polyester housing F16, IP66/IP67, NEMA 4X, thread NPT1/2												
<b>(3)</b>	<b>Electrical output</b>												
E5	FEM22, 3-wire, PNP, 10 V DC to 45 V DC												
WA	FEM24, relay, DPDT, 19 V AC to 253 V AC, 19 V DC to 55 V DC												
<b>A</b>	<b>Additional equipment</b>												
A	Basic version												
<b>(4)</b>	<b>Approval</b>												
NA	Version for non-explosion-hazardous area												
EX	ATEX II 1/2D Ex ta/tb IIIC T135°C Da/Db												
CU	CSA General Purpose, CSA C US												
IK	IECEX Ex ta/tb IIIC T135°C Da/Db												

**Connection**

**Electronic insert FEM22 (E5)**

Three-wire DC connection

- preferred in conjunction with programmable logic controllers (PLC), DI modules as per EN 61131-2
- positive signal at electronics switch output (PNP)
- Output blocked at level limit.

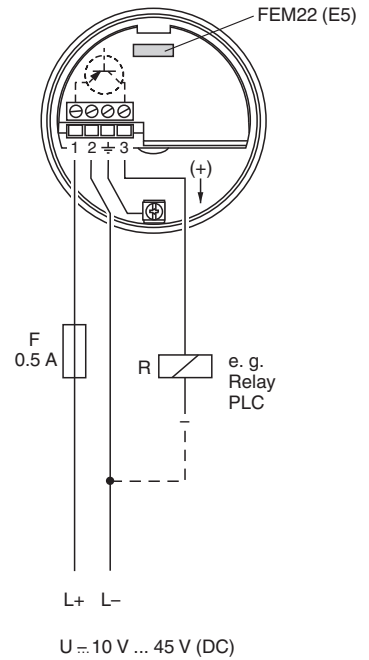

**Electronic insert FEM24 (WA)**

Universal current connection with relay output

- Power supply: Please note the different voltage ranges for AC and DC.
- When connecting a device with high inductance, provide a spark arrester to protect the relay contact. A fine-wire fuse (depending on the load connected) protects the relay contact in the event of a short-circuit. Both relay contacts switch simultaneously. DPDT (double pole double throw)

\* When jumpered, the relay output works with NPN logic.  
 \*\* see "Connectable load"

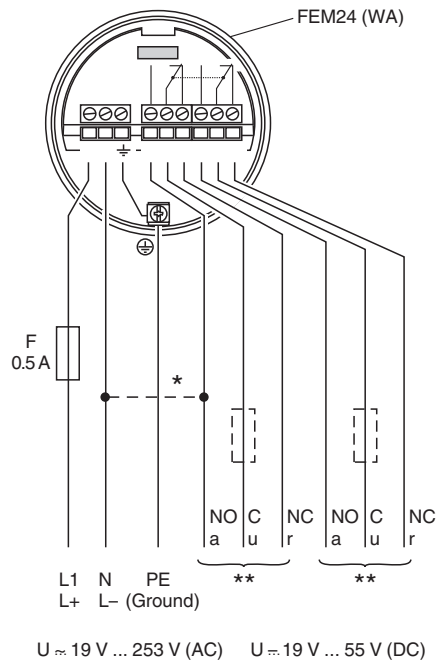

**Mounting**

**Mounting position**

Release date: 2024-09-04 Date of issue: 2024-09-04 Filename: 272173\_eng.pdf

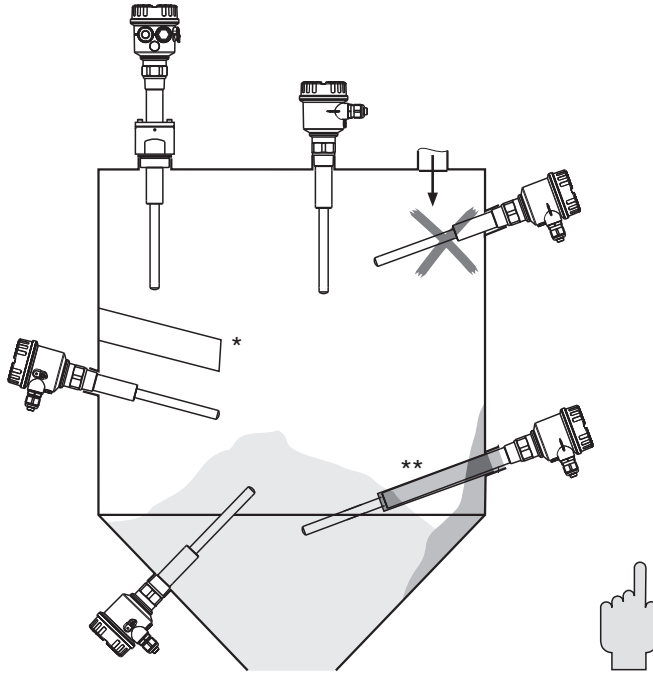

Horizontal installation/vertical installation

- \* with protective cover (to be provided by customer)
- \*\* with protecting tube (to be provided by customer)