

Digital Input FB1208B3

- 8-channel
- Inputs Ex ia
- Installation in suitable enclosures in Zone 1
- Module can be exchanged under voltage (hot swap)
- Dry contact or NAMUR inputs
- Positive or negative logic selectable
- Simulation mode for service operations (forcing)
- Line fault detection (LFD)
- Permanently self-monitoring
- On/Off delay



Function

The device accepts digital input signals of NAMUR sensors or mechanical contacts from the hazardous area. Open or short circuit line fault alarms are detected. The inputs are galvanically isolated from the bus and the power supply (EN 60079-11).

Connection

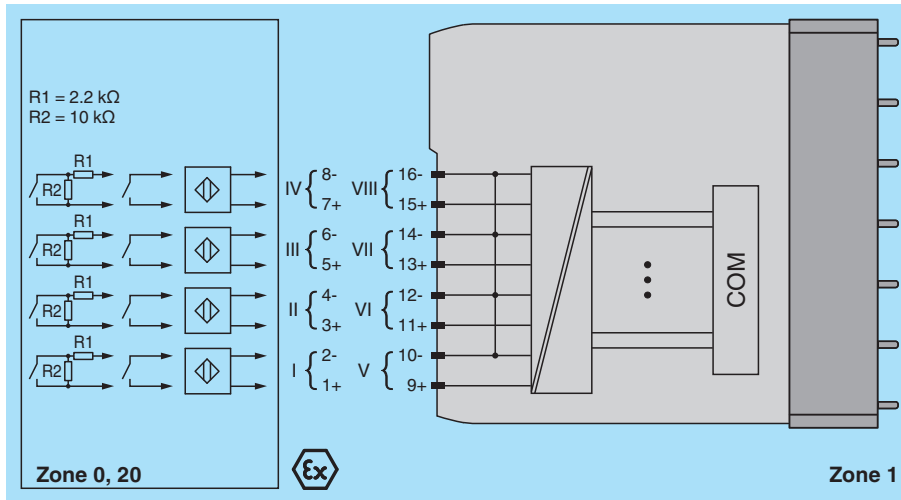

Technical Data

Slots			
Occupied slots	2		
Supply			
Connection	backplane bus		
Rated voltage	U_r	12 V DC , only in connection with the power supplies FB92**	
Power dissipation	0.95 W		
Power consumption	0.95 W		
Internal bus			
Connection	backplane bus		
Interface	manufacturer-specific bus to standard com unit		
Digital input			
Number of channels	8		

Release date: 2023-06-20 Date of issue: 2023-06-20 Filename: 276216_eng.pdf

Technical Data

Sensor interface		
Connection		NAMUR sensor
Connection [2]		volt-free contact
Connection		channel I: 1+, 2-; channel II: 3+, 4-; channel III: 5+, 6-; channel IV: 7+, 8-; channel V: 9+, 10-; channel VI: 11+, 12-; channel VII: 13+, 14-; channel VIII: 15+, 16-
Rated values		acc. to EN 60947-5-6 (NAMUR)
Switching point/switching hysteresis		1.2 ... 2.1 mA / ± 0.2 mA
Internal resistor	R _i	1 kΩ
Line fault detection		
Connection		can be switched on/off for each channel via configuration tool
Short-circuit		mechanical switch with additional resistors (see connection diagram) proximity switches without additional wiring
Open-circuit		< 360 Ω
Minimum pulse duration		< 0.35 mA
		1 ms
Indicators/settings		
LED indication		LED green: supply LED red: line fault
Coding		optional mechanical coding via front socket
Directive conformity		
Electromagnetic compatibility		
Directive 2014/30/EU		EN 61326-1:2013
Conformity		
Electromagnetic compatibility		NE 21
Degree of protection		IEC 60529
Environmental test		EN 60068-2-14
Shock resistance		EN 60068-2-27
Vibration resistance		EN 60068-2-6
Damaging gas		EN 60068-2-42
Relative humidity		EN 60068-2-78
Ambient conditions		
Ambient temperature		-40 ... 60 °C (-40 ... 140 °F)
Storage temperature		-40 ... 85 °C (-40 ... 185 °F)
Relative humidity		95 % non-condensing
Shock resistance		shock type I, shock duration 11 ms, shock amplitude 15 g, number of shocks 18
Vibration resistance		frequency range 10 ... 150 Hz; transition frequency: 57.56 Hz, amplitude/acceleration ± 0.075 mm/1 g; 10 cycles frequency range 5 ... 100 Hz; transition frequency: 13.2 Hz amplitude/acceleration ± 1 mm/0.7 g; 90 minutes at each resonance
Damaging gas		designed for operation in environmental conditions acc. to ISA-S71.04-1985, severity level G3
Mechanical specifications		
Degree of protection		IP20 (module) , a separate housing is required acc. to the system description
Connection		removable front connector with screw flange (accessory) wiring connection via spring terminals (0.14 ... 1.5 mm ²) or screw terminals (0.08 ... 1.5 mm ²)
Mass		approx. 945 g
Dimensions		57 x 107 x 132 mm (2.2 x 4.2 x 5.2 inch)
Data for application in connection with hazardous areas		
EU-type examination certificate		Presafe 19 ATEX 14058U
Marking		Ⓢ II 2(1)G Ex db eb q [ia Ga] IIC Gb II (1)D [Ex ia Da] IIIC I (M1) [Ex ia Ma] I
Input		
Voltage	U _o	14.9 V
Current	I _o	15.7 mA
Power	P _o	58.2 mW (linear characteristic)
Galvanic isolation		

Technical Data

Input/power supply, internal bus	safe electrical isolation acc. to EN 60079-11, voltage peak value 375 V
Directive conformity	
Directive 2014/34/EU	EN IEC 60079-0:2018+AC:2020 EN 60079-1:2014 EN 60079-5:2015 EN 60079-7:2015+A1:2018 EN 60079-11:2012
International approvals	
ATEX approval	Presafe 19 ATEX 14058U
IECEX approval	IECEX PRE 19.0013U
Approved for	Ex db eb q [ia Ga] IIC Gb [Ex ia Da] IIIC [Ex ia Ma] I
General information	
System information	The module has to be mounted in appropriate backplanes and housings (FB92**) in Zone 1, 2, 21, 22 or outside hazardous areas (gas or dust). Here, observe the corresponding EC-type examination certificate.
Supplementary information	EC-Type Examination Certificate, Statement of Conformity, Declaration of Conformity, Attestation of Conformity and instructions have to be observed where applicable. For information see www.pepperl-fuchs.com .

Assembly

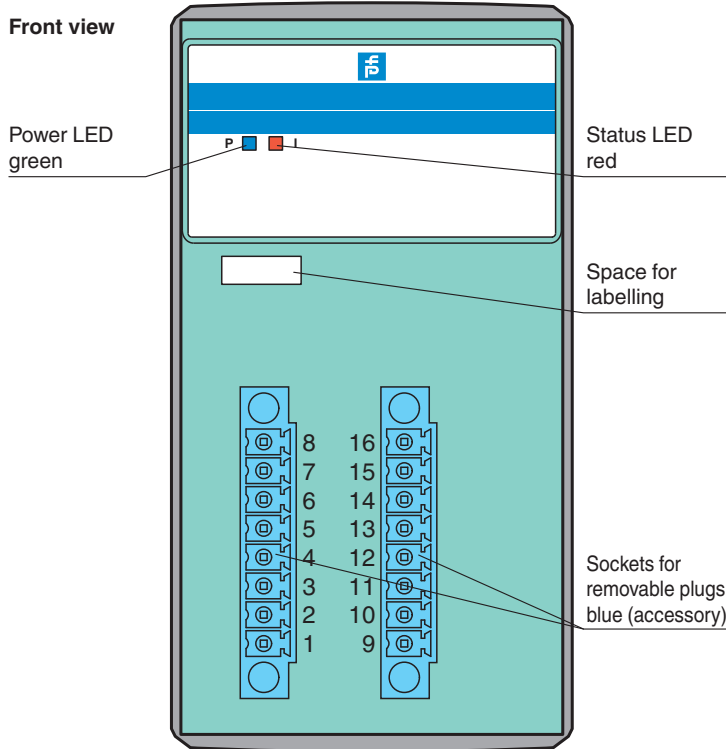

Accessories

FB9224*	Field Unit
FB9225*	Redundancy Field Unit
FB9248*	Field Unit

Release date: 2023-06-20 Date of issue: 2023-06-20 Filename: 276216_eng.pdf