

# HART Output Isolator FB4205B3

- 4-channel
- Outputs Ex ia
- Installation in suitable enclosures in Zone 1
- Module can be exchanged under voltage (hot swap)
- Analog output module for 0/4 mA ... 20 mA
- HART communication via field bus or service bus
- Simulation mode for service operations (forcing)
- Line fault detection (LFD): one LED per channel
- Permanently self-monitoring



## Function

The device drives positioners, proportional valves, I/P converters, or local indicators. Open and short-circuit line faults are detected. The outputs are galvanically isolated from the bus and the power supply.

## Connection

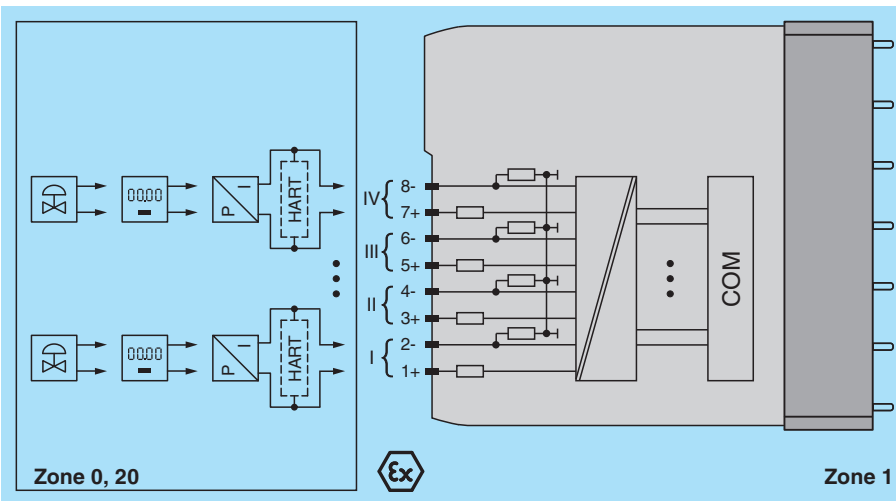

## Technical Data

<b>Slots</b>	
Occupied slots	2
<b>Supply</b>	
Connection	backplane bus
Rated voltage	$U_r$ 12 V DC , only in connection with the power supplies FB92**
Power dissipation	1.5 W
Power consumption	3 W
<b>Internal bus</b>	
Connection	backplane bus
Interface	manufacturer-specific bus to standard com unit
<b>Analog input</b>	
HART communication	yes
HART secondary variable	no

Release date: 2023-06-20 Date of issue: 2023-06-20 Filename: 276325\_eng.pdf

## Technical Data

<b>Analog output</b>	
Number of channels	4
Suitable field devices	
Field device	Proportional Valve
Field device [2]	I/P converters
Field device [3]	on-site display
Connection	terminals 1+, 2-, 3+, 4-, 5+, 6-, 7+, 8-
Current	0 ... 20 mA short-circuit protected
Line fault detection	can be switched on/off for each channel via configuration tool , configurable via configuration tool
Short-circuit	No
Open-circuit	deviation of preset output value > 0.5 mA
Load	max. 750 Ω at 20 mA
HART communication	yes
HART secondary variable	yes
Watchdog	within 0.5 s the device goes in safe state, e.g. after loss of communication
<b>Transfer characteristics</b>	
Deviation	
After calibration	0.1 % of the signal range at 20 °C (68 °F)
Influence of ambient temperature	0.1 %/10 K of the signal range
Resolution	12 Bit (0 ... 26 mA)
Refresh time	approx. 100 ms (4 channels)
<b>Indicators/settings</b>	
LED indication	Power LED (P) green: supply Diagnostic LED (I) red: module fault , red flashing: communication error , white: fixed parameter set (parameters from com unit are ignored) , white flashing: requests parameters from com unit Status LED (1-4) red: line fault (lead breakage or short circuit)
Coding	optional mechanical coding via front socket
<b>Directive conformity</b>	
Electromagnetic compatibility	
Directive 2014/30/EU	EN 61326-1:2013
<b>Conformity</b>	
Electromagnetic compatibility	NE 21:2007
Degree of protection	IEC 60529:2000
Environmental test	EN 60068-2-14:2009
Shock resistance	EN 60068-2-27:2009
Vibration resistance	EN 60068-2-6:2008
Damaging gas	EN 60068-2-42:2003
Relative humidity	EN 60068-2-78:2001
<b>Ambient conditions</b>	
Ambient temperature	-40 ... 60 °C (-40 ... 140 °F)
Storage temperature	-40 ... 85 °C (-40 ... 185 °F)
Relative humidity	95 % non-condensing
Shock resistance	shock type I, shock duration 11 ms, shock amplitude 15 g, number of shocks 18
Vibration resistance	frequency range 10 ... 150 Hz; transition frequency: 57.56 Hz, amplitude/acceleration ± 0.075 mm/1 g; 10 cycles frequency range 5 ... 100 Hz; transition frequency: 13.2 Hz amplitude/acceleration ± 1 mm/0.7 g; 90 minutes at each resonance
Damaging gas	designed for operation in environmental conditions acc. to ISA-S71.04-1985, severity level G3
<b>Mechanical specifications</b>	
Degree of protection	IP20 (module) , a separate housing is required acc. to the system description
Connection	removable front connector with screw flange (accessory) wiring connection via spring terminals (0.14 ... 1.5 mm <sup>2</sup> ) or screw terminals (0.08 ... 1.5 mm <sup>2</sup> )
Mass	approx. 750 g

## Technical Data

Dimensions	57 x 107 x 132 mm (2.2 x 4.2 x 5.2 inch)		
<b>Data for application in connection with hazardous areas</b>			
EU-type examination certificate	Presafe 19 ATEX 14057U		
Marking		Ⓢ II 2(1)G Ex db eb q [ia Ga] IIC Gb II (1)D [Ex ia Da] IIC I (M1) [Ex ia Ma] I	
<b>Supply</b>			
Voltage	$U_o$	27 V	
Current	$I_o$	87 mA	
Power	$P_o$	575 mW (linear characteristic)	
Input		Ex ia	
Output		Ex ia	
Voltage	$U_o$	27 V	
Current	$I_o$	87 mA	
Power	$P_o$	575 mW (linear characteristic)	
Galvanic isolation			
Output/power supply, internal bus		safe electrical isolation acc. to EN 60079-11:2007 , voltage peak value 375 V	
Directive conformity			
Directive 2014/34/EU		EN IEC 60079-0:2018+AC:2020 EN 60079-1:2014 EN 60079-5:2015 EN 60079-7:2015+A1:2018 EN 60079-11:2012	
<b>International approvals</b>			
ATEX approval		Presafe 19 ATEX 14057U	
IECEx approval		IECEx PRE 19.0012U	
Approved for		Ex db eb q [ia Ga] IIC Gb [Ex ia Da] IIC [Ex ia Ma] I	
<b>General information</b>			
System information		The module has to be mounted in appropriate backplanes and housings (FB92**) in Zone 1, 2, 21, 22 or outside hazardous areas (gas or dust). Here, observe the corresponding EC-type examination certificate.	
Supplementary information		EC-Type Examination Certificate, Statement of Conformity, Declaration of Conformity, Attestation of Conformity and instructions have to be observed where applicable. For information see <a href="http://www.pepperl-fuchs.com">www.pepperl-fuchs.com</a> .	