



Segment Coupler

FieldConnex® Fieldbus

KFD2-BR-1.PA.1500

- Output: 24 ... 26 V/400 mA
- Couples PROFIBUS PA devices transparently to PROFIBUS DP
- High-power trunk for high device count and long cable lengths
- Installation in Zone 2/Class I, Div. 2
- Up to 1.5 MBit auto-adapting
- PROFIBUS DP terminator selectable
- Power Rail support

Segment coupler 1, power supply and gateway for PROFIBUS DP to PROFIBUS PA communication



Function

The FieldConnex® basic Segment Coupler is an all-in-one gateway and fieldbus power supply for connecting PROFIBUS PA to PROFIBUS DP transparently. The power output suits long cable lengths and high device counts. Device couplers provide explosion protection for live work at the spur where needed.

Communication is transparent between DP and PA. The gateway of the Segment Coupler makes each PA device appear as if it was connected to DP: This relates to addressing, cyclic/acyclic data exchange, and the transfer rate. Segment design is clear and easy to understand without subnetworks. The gateway itself is configuration-free. All in all, these features significantly reduce engineering work.

Availability and a long service life are achieved through a passive impedance filter and a design optimized for low heat dissipation. The fieldbus diagnostic handheld (FDH-1) connects directly to test plug sockets located on the plug-in terminal.

Connection

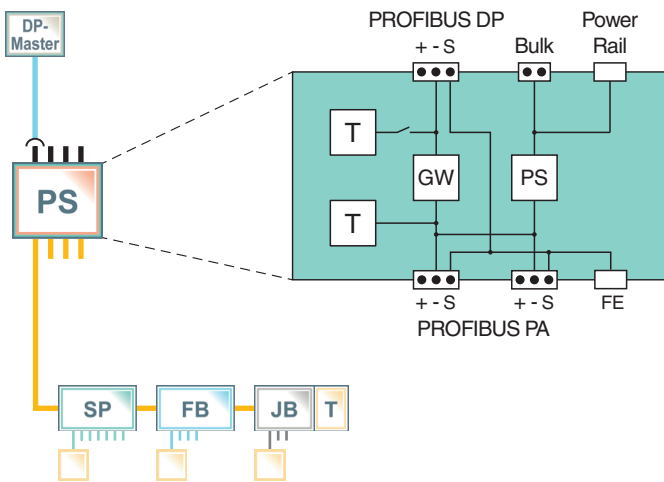

Technical Data

General specifications

Installation in hazardous area Zone 2 / Div. 2

Supply

Connection Power Rail or terminals 11 (L+), 12 (L-)

Rated voltage U_r 20 ... 30 V DC

Ripple $\leq 10\%$

Rated current I_r 640 mA ... 365 mA

Power dissipation max 2.5 W

Fieldbus connection

Release date: 2024-12-17 Date of issue: 2024-12-17 Filename: 277830_eng.pdf

Technical Data

Number of segments		1
Rated voltage	U_N	12.6 ... 13.4 V
PROFIBUS PA		
Connection		3+, 6+, 2-, 5-, 1 shield, 4 shield
Rated voltage		24 ... 26 V
Rated current		max. 400 mA
Terminating impedance		100 Ω , integrated
PROFIBUS DP		
Connection		terminals 7 RxD/TxD-P, 8 RxD/TxD-N, 9 shield, 10 FE
Baud rate		1.5 MBit/s max.
Indicators/operating means		
Switch		PROFIBUS DP terminator
LED PWR		green: Power on
LED DP/ERR		red 2 Hz flashing: DP error red on: Hardware error red off: DP communication detected
LED PA		red 2 Hz flashing: No PA communication or overload Off: PA communication OK
Galvanic isolation		
PROFIBUS DP/PROFIBUS PA		functional insulation acc. to IEC 62103, rated insulation voltage 50 V AC /70 V DC
PROFIBUS DP/Supply		basic insulation according to IEC/EN 61010, rated insulation voltage 253 V AC /357 V DC
PROFIBUS PA/Supply		basic insulation according to IEC/EN 61010, rated insulation voltage 253 V AC /357 V DC
Directive conformity		
Electromagnetic compatibility		
Directive 2014/30/EU		EN 61326-1:2013
Standard conformity		
Electromagnetic compatibility		
Degree of protection		NAMUR NE 21
Fieldbus standard		IEC/EN 60529
Climatic conditions		EN 50170/2
Shock resistance		DIN IEC 721
Vibration resistance		EN 60068-2-27
		EN 60068-2-6
Ambient conditions		
Ambient temperature		-40 ... 60 °C (-40 ... 140 °F)
Storage temperature		-40 ... 85 °C (-40 ... 185 °F)
Relative humidity		< 95 % non-condensing
Shock resistance		15 g 11 ms
Vibration resistance		1 g 10 ... 150 Hz
Pollution degree		max. 2, according to IEC 60664
Corrosion resistance		acc. to ISA-S71.04-1985, severity level G3
Mechanical specifications		
Connection type		screw terminal , pluggable
Core cross section		up to 2.5 mm ²
Housing material		Polycarbonate
Degree of protection		IP20
Mass		180 g
Mounting		DIN rail mounting
Data for application in connection with hazardous areas		
Certificate		TÜV 16 ATEX 7831 X
Marking		Ⓜ II 3G Ex ec IIC T4 Gc
Directive conformity		
Directive 2014/34/EU		EN IEC 60079-0:2018+AC:2020 , EN 60079-7:2015+A1:2018
International approvals		
CSA approval		CSA 16.70064204

Technical Data

Approved for	Class I, Division 2, Groups A, B, C, D Class I, Zone 2, Ex nA IIC T4 Gc
IECEX approval	IECEX TUR 16.0006X
Approved for	Ex ec IIC T4 Gc
General information	
Supplementary information	Observe the certificates, declarations of conformity, instruction manuals, and manuals where applicable. For information see www.pepperl-fuchs.com .

Assembly

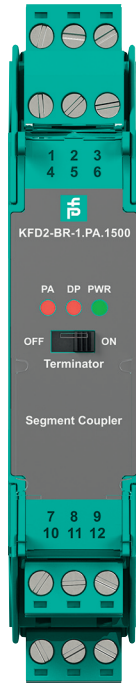

Additional Information

Dimensions and Assembly

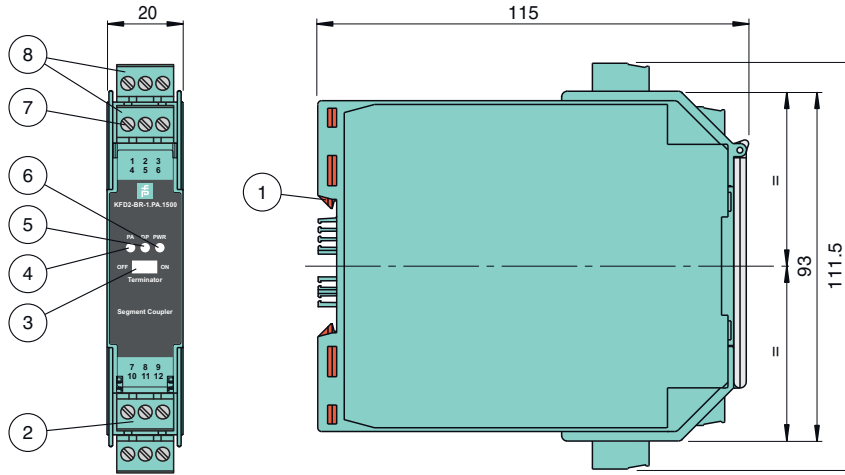

Description:

- 1 Extendable lugs
- 2 PROFIBUS DP connection
- 3 Switch: Terminator for PROFIBUS DP
- 4 LED PA: Status of PROFIBUS PA
- 5 LED DP: Status of PROFIBUS DP and hardware
- 6 LED PWR: Status of power supply
- 7 Removable terminal with test plug sockets
- 8 PROFIBUS PA trunk connections

Release date: 2024-12-17 Date of issue: 2024-12-17 Filename: 277830_eng.pdf