

Digital Output with Position Feedback

LB2017E

- 1-channel
- 1 digital output, 2 digital inputs
- Installation in Zone 2 or safe area
- Inputs and output Ex ic
- Line fault detection switched on and off
- Positive or negative logic selectable
- Simulation mode for service operations (forcing)
- Permanently self-monitoring
- Output with watchdog
- Output with bus-independent safety shutdown
- Module can be exchanged under voltage



Function

The digital output features 1 output with 2 feedback inputs. The device can be used to switch solenoids, sounders, or indicators (without line fault detection) in the field. Furthermore, the device accepts digital input signals of NAMUR sensors or mechanical contacts from the field. The output can be switched off via a contact. This can be used for bus-independent safety applications. Open and short circuit line faults are detected in on and off state. The intrinsically safe inputs and the output are galvanically isolated from the bus and the power supply.

Connection Assignment

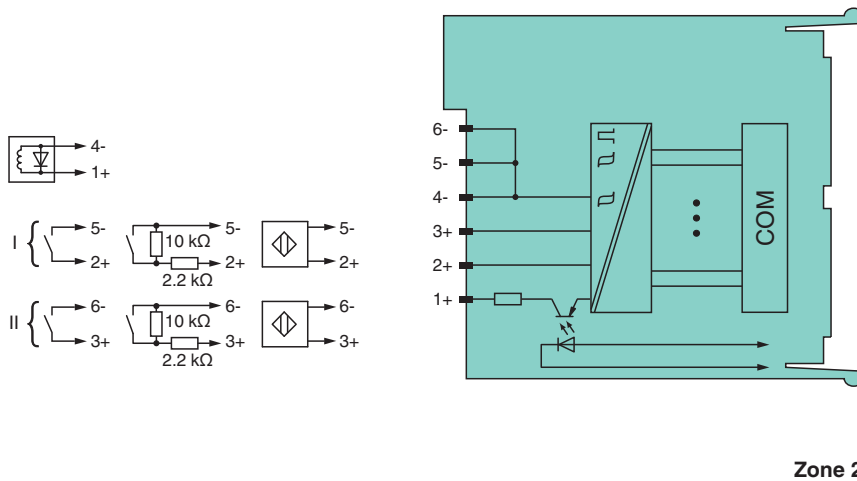

Technical Data

Slots	
Occupied slots	1
Supply	
Connection	backplane bus
Rated voltage	U_r Use only in connection with the power supplies LB9***
Power dissipation	1.3 W
Power consumption	1.85 W
Internal bus	
Connection	backplane bus
Interface	manufacturer-specific bus to standard com unit

Release date: 2022-10-21 Date of issue: 2022-10-21 Filename: 281972_eng.pdf

Technical Data

Digital input		
Number of channels		2
Sensor interface		
Connection		NAMUR sensor
Connection [2]		volt-free contact
Connection		channel I: 2+, 5-; channel II: 3+, 6-
Rated values		acc. to EN 60947-5-6 (NAMUR)
Switching point/switching hysteresis		1.2 ... 2.1 mA / ± 0.2 mA
Voltage		8.2 V
Internal resistor	R_i	1 k Ω
Line fault detection		can be switched on/off for each channel via configuration tool
Connection		mechanical switch with additional resistors (see connection diagram) proximity switches without additional wiring
Short-circuit		< 360 Ω
Open-circuit		< 0.35 mA
Minimum pulse duration		1 ms
Digital output		
Number of channels		1
Suitable field devices		
Field device		Solenoid Valve
Field device [2]		audible alarm
Field device [3]		visual alarm
Connection		channel I: 1+, 4-
Internal resistor	R_i	131 Ω
Current limit	I_{max}	50 mA
Open loop voltage	U_s	16.5 V
Line fault detection		can be switched on/off for each channel via configuration tool , also when turned off (every 2.5 s the valve is turned on for 2 ms)
Short-circuit		< 50 Ω
Open-circuit		> 10 k Ω
Response time		20 ms (depending on bus cycle time)
Watchdog		within 0.5 s the device goes in safe state, e.g. after loss of communication
Indicators/settings		
LED indication		Power LED (P) green: supply Diagnostic LED (I) red: module fault , red flashing: communication error , white: fixed parameter set (parameters from com unit are ignored) , white flashing: requests parameters from com unit Status LED (O: output, I1: input 1, I2: input 2) red: line fault (lead breakage or short circuit) , yellow: state of digital I/O (0/1)
Coding		optional mechanical coding via front socket
Directive conformity		
Electromagnetic compatibility		
Directive 2014/30/EU		EN 61326-1:2013
Conformity		
Electromagnetic compatibility		NE 21
Degree of protection		IEC 60529
Environmental test		EN 60068-2-14
Shock resistance		EN 60068-2-27
Vibration resistance		EN 60068-2-6
Damaging gas		EN 60068-2-42
Relative humidity		EN 60068-2-78
Ambient conditions		
Ambient temperature		-40 ... 60 °C (-40 ... 140 °F)
Storage temperature		-40 ... 85 °C (-40 ... 185 °F)
Relative humidity		95 % non-condensing

Technical Data

Altitude		max. 2000 m
Shock resistance		shock type I, shock duration 11 ms, shock amplitude 15 g, number of shocks 18
Vibration resistance		frequency range 10 ... 150 Hz; transition frequency: 57.56 Hz, amplitude/acceleration ± 0.075 mm/1 g; 10 cycles frequency range 5 ... 100 Hz; transition frequency: 13.2 Hz amplitude/acceleration ± 1 mm/0.7 g; 90 minutes at each resonance
Damaging gas		designed for operation in environmental conditions acc. to ISA-S71.04-1985, severity level G3
Mechanical specifications		
Degree of protection		IP20 when mounted on backplane
Connection		removable front connector with screw flange (accessory) wiring connection via spring terminals (0.14 ... 1.5 mm ²) or screw terminals (0.08 ... 1.5 mm ²)
Mass		approx. 110 g
Dimensions		16 x 100 x 102 mm (0.63 x 3.9 x 4 inch)
Data for application in connection with hazardous areas		
EU-type examination certificate		EXA 16 ATEX 0035X
Marking		Ⓔ II 3 G Ex nA [ic] IIC T4 Gc
Input		
Voltage	U _o	10 V
Current	I _o	13 mA
Power	P _o	33 mW (linear characteristic)
Internal capacitance	C _i	1.2 nF
Internal inductance	L _i	0 mH
Output		
Voltage	U _o	17.8 V
Current	I _o	162 mA
Power	P _o	721 mW
Internal capacitance	C _i	12 nF
Internal inductance	L _i	0 mH
Galvanic isolation		
Input/power supply, internal bus		safe electrical isolation acc. to EN 60079-11, voltage peak value 375 V
Output/power supply, internal bus		safe electrical isolation acc. to EN 60079-11, voltage peak value 375 V
Directive conformity		
Directive 2014/34/EU		EN IEC 60079-0:2018+AC:2020 EN 60079-11:2012 EN 60079-15:2010
International approvals		
ATEX approval		EXA 16 ATEX 0035X
IECEx approval		IECEx EXA 16.0010X
Approved for		Ex nA [ic] IIC T4 Gc
General information		
System information		The module has to be mounted in appropriate backplanes (LB9***) in Zone 2 or outside hazardous areas. Here, observe the corresponding declaration of conformity. For use in hazardous areas (e. g. Zone 2, Zone 22 or Div. 2) the module must be installed in an appropriate enclosure.
Supplementary information		Observe the certificates, declarations of conformity, instruction manuals, and manuals where applicable. For information see www.pepperl-fuchs.com .

Assembly

Front view

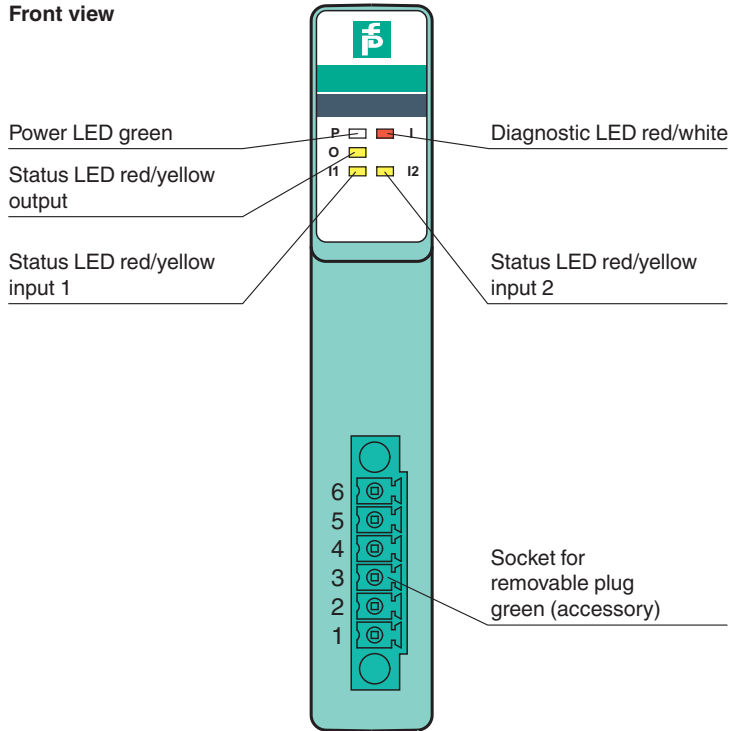

Release date: 2022-10-21 Date of issue: 2022-10-21 Filename: 281972_eng.pdf

Characteristic Curve

Load calculation

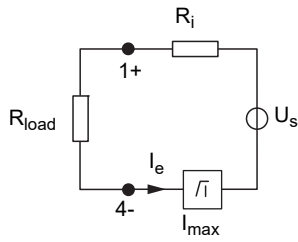

R_{load} = Field loop resistance
 $U_e = U_s - R_i \times I_e$
 $I_e = U_s / (R_i + R_{load})$

Output characteristics

