

## Inductive sensor NBN3-F31K-Z8-K

- Direct mounting on standard actuators
- Fixed setting
- LEDs for switching state of sensor and solenoid valve



### Installation

The connections to this sensor are sealed with stopping plugs to protect against dirt and moisture. If not all of the connections are used in your application, then seal the remaining stopping plugs on the sensor permanently or check during initial installation and when performing regular maintenance work that the stopping plugs are secure and impermeable. If necessary, tighten the stopping plugs to a torque of 1 Nm.

### Dimensions

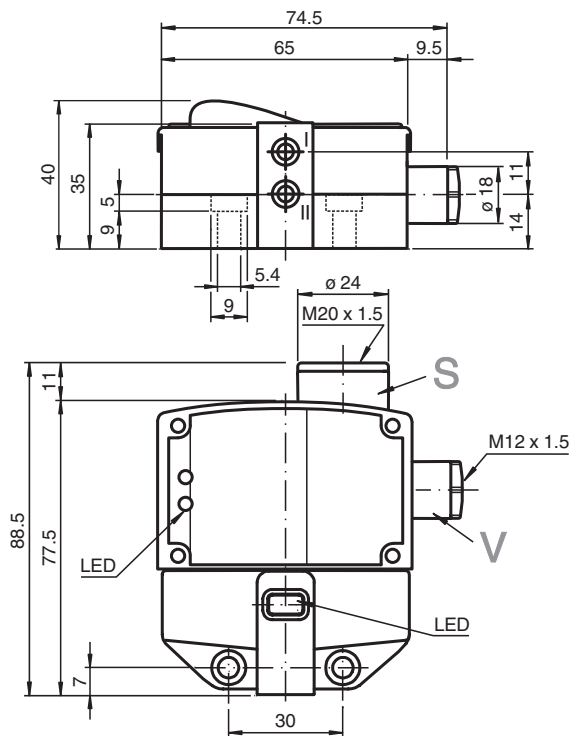

### Technical Data

#### General specifications

Switching function		2 x normally open (NO)
Output type		Two-wire
Rated operating distance	$s_n$	3 mm
Installation		flush mountable
Output polarity		DC

Release date: 2025-07-02 Date of issue: 2025-07-02 Filename: 282689\_eng.pdf

## Technical Data

Assured operating distance	$s_a$	0 ... 2.43 mm
Actual operating distance	$s_r$	2.7 ... 3.3 mm typ. 3 mm
Reduction factor $r_{AI}$		0.5
Reduction factor $r_{Cu}$		0.4
Reduction factor $r_{304}$		1
Reduction factor $r_{S137}$		1.1
Output type		4-wire
<b>Nominal ratings</b>		
Operating voltage	$U_B$	6 ... 60 V DC
Switching frequency	$f$	0 ... 500 Hz
Hysteresis	$H$	typ. 5 %
Reverse polarity protection		reverse polarity tolerant
Short-circuit protection		pulsing
Voltage drop	$U_d$	$\leq 5.5$ V
Operating current	$I_L$	4 ... 100 mA
Lowest operating current	$I_m$	4 mA
Off-state current	$I_r$	0.5 ... 0.9 mA typ. 0.65 mA
Time delay before availability	$t_v$	$\leq 40$ ms
Switching state indicator		LED, yellow
Valve status indicator		LED, yellow
<b>Limit data</b>		
Tightening torque, fastening screws		0.4 Nm
<b>Functional safety related parameters</b>		
MTTF <sub>d</sub>		570 a
Mission Time ( $T_M$ )		20 a
Diagnostic Coverage (DC)		0 %
<b>Valve circuit</b>		
Voltage		max. 32 V DC
Current		max. 240 mA
Short-circuit protection		no
Reverse polarity protection		yes, with reversed output LED is out of function, therefore more power for solenoid valve
<b>Compliance with standards and directives</b>		
Standard conformity		
Standards		EN IEC 60947-5-2
<b>Approvals and certificates</b>		
UL approval		cULus Listed Load Type: General Purpose Circuitry: Class 2 Power Source Enclosure Type Rating: Type 1 Supply/Switching Voltage: 60 V DC Output Switching Current: 100 mA
CCC approval		Certified by China Compulsory Certification (CCC)
<b>Ambient conditions</b>		
Ambient temperature		-25 ... 70 °C (-13 ... 158 °F)
<b>Mechanical specifications</b>		
Connection (system side)		Cage tension spring terminals
Core cross section (system side)		1.5/2.5 mm <sup>2</sup> flexible/rigid
Connection (valve side)		Cage tension spring terminals
Core cross section (valve side)		1.5/2.5 mm <sup>2</sup> flexible/rigid
Housing material		PBT
Sensing face		PBT
Degree of protection		IP67
Mass		180 g
Tightening torque, fastening screws		$\leq 5$ Nm
Tightening torque, housing screws		1 Nm

## Technical Data

Tightening torque, cable gland	M20 x 1.5 ; max. 7 Nm M12 x 1.5 ; max. 1.5 Nm
Dimensions	
Height	35 mm
Width	65 mm
Length	77.5 mm

## Connection Assignment

