



Optical reading head PGV100I-F200-B16-V15

- Mechanically rugged: no wearing parts, long operating life, maintenance-free
- CANopen interface
- Non-contact positioning on Data Matrix code tape
- Noncontact positioning with Data Matrix TAGs
- Reading of Data Matrix control codes
- Infrared light

Read head for incident light positioning system



Dimensions

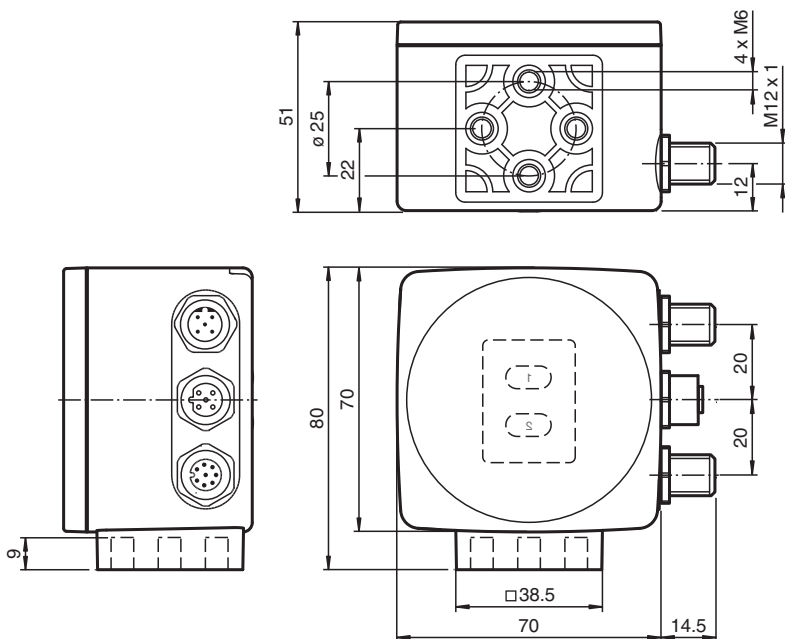

Technical Data

General specifications

Passage speed	v	≤ 8 m/s
Measuring range		max. 10000 m
Light type		Integrated LED lightning , infrared
Scan rate		40 s ⁻¹
Latency		50 ms
Read distance		100 mm
Depth of focus		± 30 mm
Reading field		120 mm x 80 mm
Ambient light limit		100000 Lux
Accuracy		± 0.2 mm

Nominal ratings

Release date: 2024-08-07 Date of issue: 2024-08-07 Filename: 285693-100002_eng.pdf

Technical Data

Camera			
Type	CMOS , Global shutter		
Processor			
Clock pulse frequency	600 MHz		
Speed of computation	4800 MIPS		
Digital resolution	32 Bit		
Functional safety related parameters			
MTTF _d	83 a		
Mission Time (T _M)	10 a		
Diagnostic Coverage (DC)	0 %		
Indicators/operating means			
LED indication	7 LEDs (communication, alignment aid, status information)		
Electrical specifications			
Operating voltage	U _B	24 V DC ± 15% , PELV	
No-load supply current	I ₀	max. 400 mA	
Power consumption	P ₀	6 W	
Interface			
Interface type	CANopen , galvanically isolated		
Data output code	binary code		
Transfer rate	max. 1 MBit/s		
Interface 2			
Interface type	USB Service		
Input			
Input type	1 function input 0-level: -U _B or unwired 1-level: +8 V ... +U _B , programmable		
Input impedance	≥ 27 kΩ		
Output			
Output type	1 to 3 switch outputs , programmable , short-circuit protected		
Switching voltage	Operating voltage		
Switching current	150 mA each output		
Conformity			
Shock resistance	EN 60068-2-27:2009		
Vibration resistance	EN 60068-2-6:2008		
Emitted interference	EN 61000-6-4:2007+A1:2011		
Noise immunity	EN 61000-6-2:2005		
Photobiological safety	exempt group according to EN 62471:2008		
Approvals and certificates			
CE conformity	CE		
UL approval	cULus Listed, Class 2 Power Source, Type 1 enclosure		
CCC approval	CCC approval / marking not required for products rated ≤36 V		
Ambient conditions			
Operating temperature	0 ... 60 °C (32 ... 140 °F) , -20 ... 60 °C (-4 ... 140 °F) (noncondensing; prevent icing on the lens!)		
Relative humidity	90 % , noncondensing		
Mechanical specifications			
Connection type	8-pin, M12x1 connector, standard (supply+IO) 5-pin, M12x1 socket, A-coded (bus out/termination) 5-pin, M12x1 connector, A-coded (bus in)		
Degree of protection	IP67		
Material			
Housing	PC/ABS		
Mass	approx. 200 g		
Dimensions			
Height	70 mm		

Technical Data

Width	70 mm
Depth	50 mm
Factory settings	
X resolution (protocol)	0.1 mm
Y resolution (protocol)	0.1 mm
Speed resolution (protocol)	0.1 m/s
Angle resolution	0.1 °
Baud rate	500 kBit/s
Extrapolation	On
Read head address	3

Connection

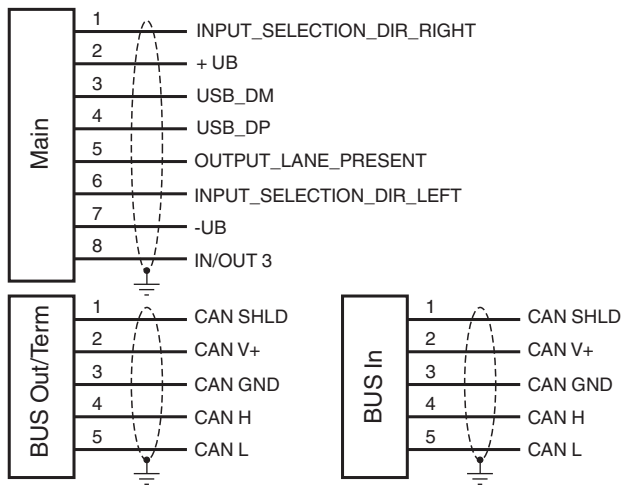

Connection Assignment

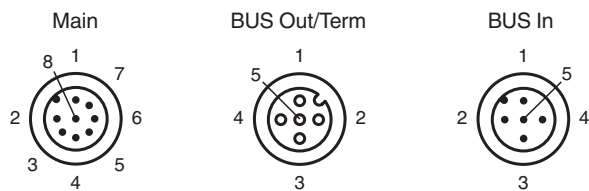

Function Principle

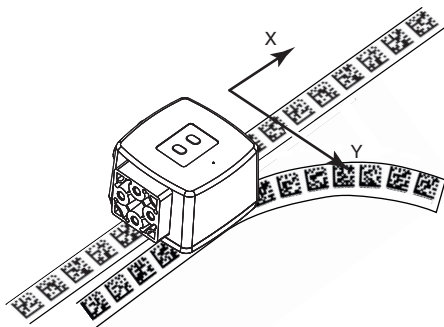

Release date: 2024-08-07 Date of issue: 2024-08-07 Filename: 285693-100002_eng.pdf

Function Principle

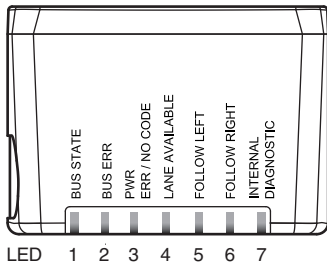
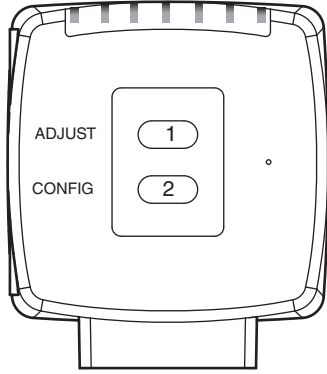

Release date: 2024-08-07 Date of issue: 2024-08-07 Filename: 285693-100002_eng.pdf

Additional Information

General

The PGV... reader forms part of the positioning system in the Pepperl+Fuchs incident light process. The read head's features include a camera module and an integrated illumination unit. The reader uses these features to detect a colored strip stuck to the floor to track the lane. The reader also detects control codes and position markers in the form of Data Matrix codes attached to a self-adhesive code tape. The Data Matrix code tape is usually mounted in a fixed position instead of the colored strip or parallel to the colored strip. The reader is located on the front of an automated guided vehicle and guides this vehicle along the colored strip and/or Data Matrix code tape.

Mounting and Commissioning

Mount the reader such that the optical surface of the device captures the optimum reading distance to the colored strip and/or Data Matrix code tape (see "Technical Data"). The stability of the mounting and the manner in which the vehicle is guided ensure that the reader is not operated outside of its depth of focus range. The colored strip and/or Data Matrix code tape must not leave the maximum reading window for the reader during this process.

All readers can be adapted to optimally meet specific requirements through parameterization.

Displays and Local Controls

The PGV... reader is equipped with seven indicator LEDs for carrying out visual function checks and rapid diagnosis. The reader is equipped with two buttons at the back for activating the alignment aid and parameterization mode.

LEDs

LED	Color	Label	Meaning
1	Yellow	BUS STATE	CANopen communication active
2	Red	BUS ERR	CANopen communication error
3	Green/red	PWR ERR/NO CODE	Code detected/not detected, error
4	Yellow	LANE AVAILABLE	Lane available
5	Yellow	FOLLOW LEFT	"Follow left-hand lane" activated
6	Yellow	FOLLOW RIGHT	"Follow right-hand lane" activated
7	Red/green/yellow	INTERNAL DIAGNOSTIC	Internal diagnostics

External Parameterization

To parameterize the device externally, the parameterization code is required in the form of a Data Matrix containing the desired reader parameters. Data Matrix code cards detailing the step-by-step process for externally parameterizing the device are printed in the instruction manual for the reader.

The reader can be parameterized only within ten minutes of being switched on. If a key is pressed after ten minutes of the device being switched on, a visual signal is given by the LEDs (LED1, yellow/LED2, red/LED3, green/LED4, yellow/LED5, yellow/LED6, yellow, flashing for two seconds).

- The switchover from normal mode to parameterization mode is made by pressing button 2 on the back of the reader. To switch the device over, button 2 must be pressed and held for more than two seconds. LED4 then flashes.
Note: Parameterization mode is exited automatically if the device is inactive for one minute. In this case, the reader reverts to normal mode and operates without the settings having been changed.
- Place the parameterization code in the field of vision of the camera module. After the parameterization code is detected, the green LED3 lights up for one second. If the parameterization code is invalid, LED3 lights up in red for two seconds.
- Briefly pressing button 2 will exit parameterization mode.