

Rotation Speed Monitor S1SD-1FI-1R

- 1-channel signal conditioner
- 24 V DC supply
- Input for 2- or 3-wire sensors
- Input frequency 10 mHz ... 50 kHz
- Relay contact output
- Start-up override and restart inhibit
- Configurable by DIP switches and software
- Connection via screw terminals



Function

This signal conditioner provides the galvanic isolation between field circuits and control circuits. The device monitors the overspeed condition and the underspeed condition of a digital signal.

The device has an input for the following digital signals:

- Mechanical contacts
- 2-wire sensors (NAMUR, SN, DC, S0)
- 3-wire sensors (NPN, PNP)
- AC/DC voltage sources (magnetic sensors)
- custom-specific setting

The input is reverse polarity protected and short-circuit proofed.

The connected sensors can also be supplied externally.

The device compares the input frequency with a user-specified reference frequency. An overspeed condition or an underspeed condition is signaled via the relay contact outputs.

A fault is indicated by a red LED.

The device is easily configured by the use of DIP switches or software.

The device can be powered via terminals or Power Bus.

Connection

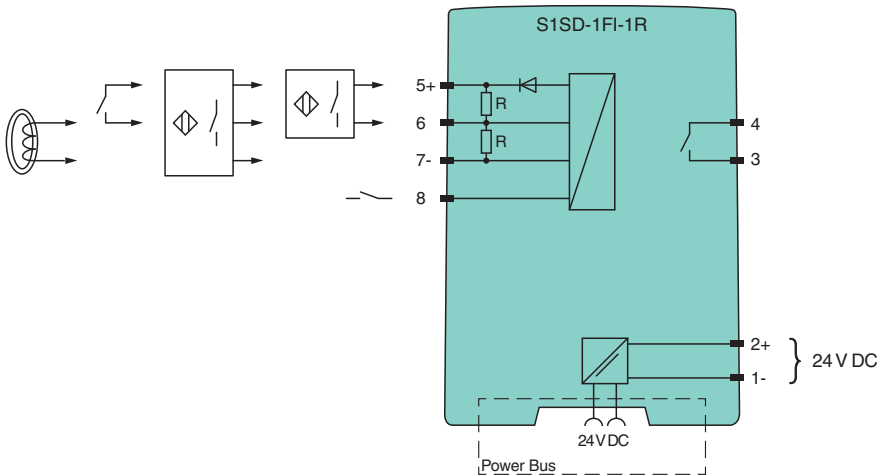

Technical Data

General specifications

Signal type Digital Input

Supply

Connection Power Bus or terminals 1-, 2+

Technical Data

Rated voltage	U_r	16.8 ... 31.2 V DC
Power dissipation		0.6 W
Power consumption		1.1 W
Interface		
Programming interface		programming socket
Input		
Connection side		field side
NAMUR sensor		
Type		2-wire
Connection		terminals 5+, 6
Signal		acc. to EN 60947-5-6 (NAMUR)
Sensor supply		8 V
Open-circuit		< 0.1 mA
Switching point		1.2 ... 2.1 mA
Short-circuit		> 6 mA
Input impedance		1 k Ω
Mechanical contact		
Type		2-wire
Connection		terminals 5+, 6
Sensor supply		15 V
External supply		≤ 32 V
Switching point		8 ... 10 V / 1.2 ... 2.1 mA
Frequency		0 ... 50 Hz , debounce filter
Input impedance		4 k Ω
SN sensor		
Type		2-wire
Connection		terminals 5+, 6
Sensor supply		8 V
Open-circuit		< 0.1 mA
Switching point		1.2 ... 2.1 mA
Short-circuit		> 6 mA
Input impedance		1 k Ω
2-wire DC sensor		
Type		2-wire
Connection		terminals 5+, 6
Signal		acc. to EN 60947-5-2
Sensor supply		16 V / 25 mA , short-circuit protected
External supply		≤ 32 V
Switching point		2 ... 5 mA
Input impedance		1 k Ω
S0 sensor		
Type		2-wire
Connection		terminals 5+, 6
Signal		acc. to EN 62053-31 , Type B
Sensor supply		15 V
Switching point		0.15 ... 2 mA
Input impedance		4 k Ω
NPN sensor		
Type		3-wire
Connection		terminals 5+, 6, 7-
Signal		acc. to EN 60947-5-2
Sensor supply		16 V / 25 mA , short-circuit protected
External supply		≤ 32 V

Technical Data

Switching point	3 ... 5 V
Input impedance	4 k Ω
PNP sensor	
Type	3-wire
Connection	terminals 5+, 6, 7-
Signal	acc. to EN 60947-5-2
Sensor supply	16 V / 25 mA , short-circuit protected
External supply	\leq 32 V
Switching point	8 ... 10 V
Input impedance	4 k Ω
AC/DC voltage source	
Connection	terminals 6, 7-
Signal	max. \pm 30 V
Switching point	150 ... 400 mV
Input impedance	4 k Ω
Function input	
Connection	terminal 8
Open loop voltage	7.5 V
Input impedance	approx. 50 k Ω
Function 1	activation start-up override
Switching point	< 3 V , edge triggered
Adjustment range	1 ... 6500 s
Function 2	reset restart inhibit
Switching point	> 12 V , edge triggered
Output	
Connection side	control side
Connection	terminals 3, 4:
Output	signal, relay
Contact loading	253 V AC/2 A/cos ϕ > 0.7; 126.5 V AC/4 A/cos ϕ > 0.7; 30 V DC/2 A resistive load
Minimum switch current	2 mA / 24 V DC
Energized/De-energized delay	\leq 20 ms / \leq 20 ms
Mechanical life	10 ⁷ switching cycles
Transfer characteristics	
Accuracy	max. 0.1 % of the measurement value
Measuring time	\leq 100 ms
Influence of ambient temperature	< 100 ppm/K of the measured value
Frequency range	0.01 ... 50000 Hz
Galvanic isolation	
Output/power supply	safe electrical isolation by reinforced insulation according to IEC/EN 61010-1, rated insulation voltage 300 V _{eff} test voltage 3 kV, 50 Hz, 1 min
Input/Other circuits	safe electrical isolation by reinforced insulation according to IEC/EN 61010-1, rated insulation voltage 300 V _{eff} test voltage 3 kV, 50 Hz, 1 min
Indicators/settings	
Display elements	LEDs
Control elements	DIP switch
Configuration	via DIP switches via software
Labeling	space for labeling at the front
Directive conformity	
Electromagnetic compatibility	
Directive 2014/30/EU	EN 61326-1:2013 (industrial locations)
Low voltage	
Directive 2014/35/EU	EN 61010-1:2010
Conformity	

Technical Data

Degree of protection	IEC 60529:2001
Protection against electrical shock	EN 61010-1:2010
Ambient conditions	
Ambient temperature	-25 ... 70 °C (-13 ... 158 °F)
Storage temperature	-40 ... 85 °C (-40 ... 185 °F)
Damaging gas	designed for operation in environmental conditions acc. to ISA-S71.04-1985, severity level G3
Mechanical specifications	
Degree of protection	IP20
Connection	screw terminals
Core cross section	0.5 ... 2.5 mm ² (20 ... 14 AWG)
Mass	approx. 60 g
Dimensions	6.2 x 97 x 107 mm (0.24 x 3.82 x 4.21 inch) (W x H x D) , housing type S1
Mounting	on 35 mm DIN mounting rail acc. to EN 60715:2001
General information	
Supplementary information	Observe the certificates, declarations of conformity, instruction manuals, and manuals where applicable. For information see www.pepperl-fuchs.com .

Assembly

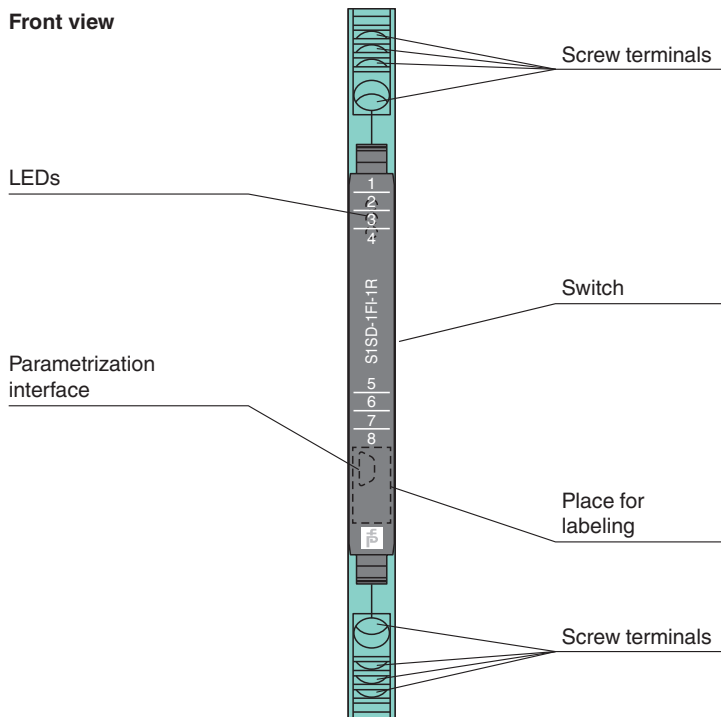





Matching System Components

	S1SD-2PF	Power Feed Module
	S-ADP-USB	Adapter with USB Interface
	POWERBUS-SETL5.250	Power bus for 35 mm DIN mounting rail, height: 7.5 mm, length: 250 mm

Release date: 2023-03-16 Date of issue: 2023-03-16 Filename: 286050_eng.pdf

Matching System Components

	POWERBUS-SETH5.250	Power bus for 35 mm DIN mounting rail, height: 15 mm, length: 250 mm
	POWERBUS-COV.250	Cover for 35 mm DIN mounting rail, length: 250 mm
	POWERBUS-CAP	End Cap for Power Bus
	VAZ-CHAIN-BU/BN70MM/1,0-25	25-point wiring link for control cabinet modules with screw terminals

Connection

External Supply

For mechanical contacts, 2-wire DC sensors and 3-wire sensors

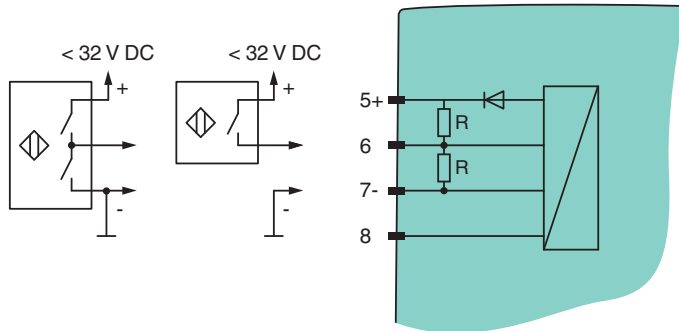

Connection

Function Input

The function input has two functions: resetting the restart inhibit and starting the start-up override.

Connect each function as shown in the diagram. Be aware that the functions can never be used at the same time. The input is edge triggered. The signal must be present for a minimum of 100 ms.

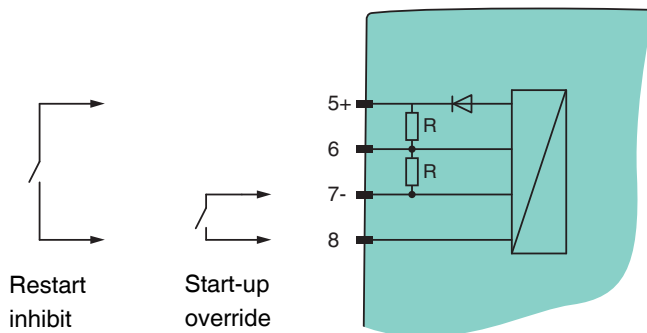

Start-up Override

The start-up override affects the trip mode MIN alarm. If the relay is in the active operating mode, it remains de-energized during the bridging delay. If the relay is in the passive operating mode, it is inevitably energized during the bridging delay. When the start-up override is bridged, the start-up override is activated once when the device is started. Do not use the restart inhibit function with a bridged input.

Restart inhibit

The restart inhibit is used to prevent the momentary exceedance of a switch point or faults from not being noticed by operating personnel. Faults can be caused by a lead breakage, lead short circuit, or insufficient supply voltage.

If the restart inhibit is active, the new status is retained after an output has been switched until one of the following events occurs.

- The device is restarted
- There is a reset signal on terminals 8 and 5

If one of these events occurs, the output is reset. The status is retained only in the following exceptional cases:

- The switch point continues to be exceeded.
- The fault continues to be present.

If you have chosen the restart inhibit for an output with a trip mode MIN alarm, the restart inhibit is inevitably triggered when the device starts, as the device starts with a measured value of 0. This means a MIN alarm is triggered immediately.

Without the start-up override, the output would then be blocked by the restart inhibit.

Operation

Modes of operation

Release date: 2023-03-16 Date of issue: 2023-03-16 Filename: 286050_eng.pdf

Trip mode MAX alarm, mode of operation active

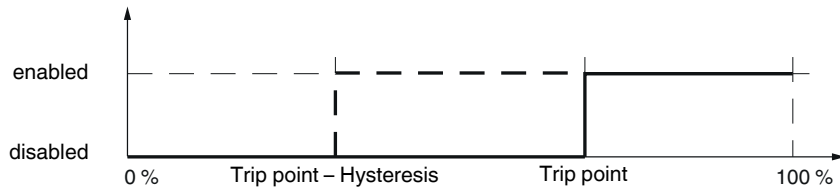

Trip mode MAX alarm, mode of operation passive

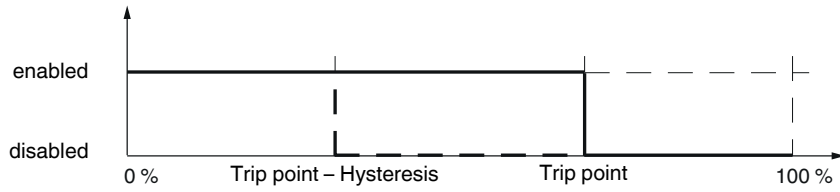

Trip mode MIN alarm, mode of operation active

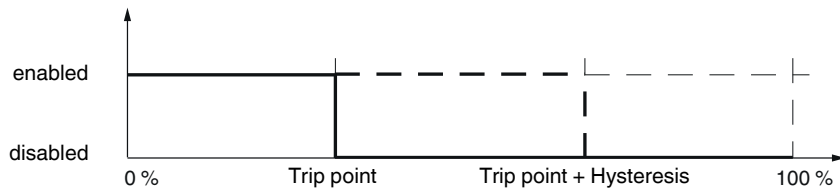

Trip mode MIN alarm, mode of operation passive

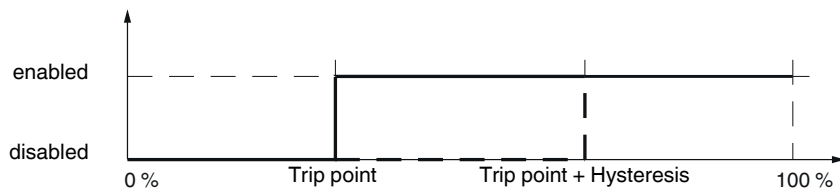

Release date: 2023-03-16 Date of issue: 2023-03-16 Filename: 286050_eng.pdf