



# SMART Transmitter Power Supply HiC2027ES

- 1-channel isolated barrier
- 24 V DC supply (bus powered)
- Input for 2-wire SMART transmitters and current sources
- Signal splitter (1 input and 2 outputs)
- Dual output 0/4 mA ... 20 mA or 0/1 V ... 5 V
- Up to SIL 3 acc. to IEC/EN 61508



## Function

This isolated barrier is used for intrinsic safety applications. The device supplies 2-wire transmitters in the hazardous area, and can also be used with current sources. It transfers the analog input signal to the safe area as two isolated output signals. Bi-directional communication is supported for SMART transmitters that use current modulation to transmit data and voltage modulation to receive data. The output is selected as a current source, current sink, or voltage source via switches. This device mounts on a HiC Termination Board.

## Application

The device supports the following SMART protocols:

- HART
- BRAIN

## Connection

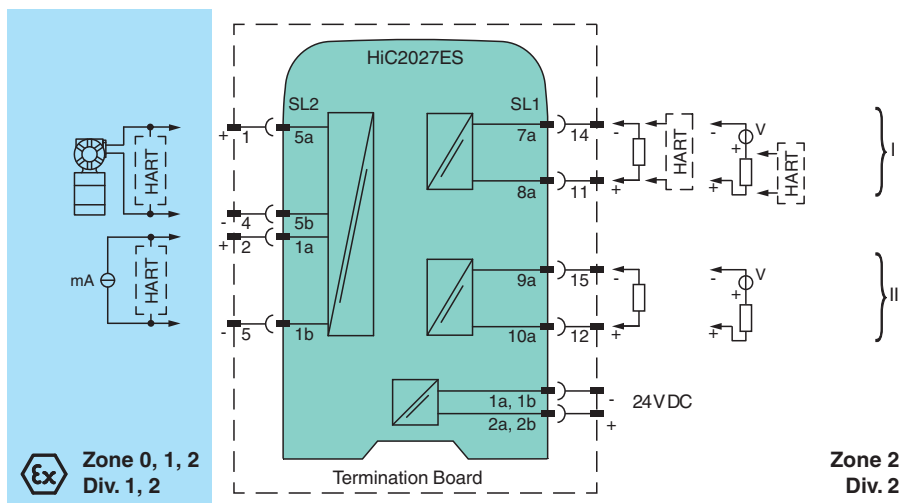

## Technical Data

General specifications	
Signal type	Analog input
Functional safety related parameters	
Safety Integrity Level (SIL)	SIL 3
Systematic capability (SC)	SC 3
Supply	

Release date: 2023-08-07 Date of issue: 2023-08-07 Filename: 286744\_eng.pdf

## Technical Data

Connection		SL1: 1a, 1b(-); 2a, 2b(+)
Rated voltage	$U_r$	20 ... 30 V DC bus powered via Termination Board
Ripple		within the supply tolerance
Rated current	$I_r$	≤ 90 mA
Power dissipation		approx. 1.4 W at 20 mA transfer current, 250 Ω in both outputs
Power consumption		2 W
<b>Input</b>		
Connection side		field side
Connection		SL2: 5a(+), 5b(-): sink SL2: 1a(+), 1b(-), 7a(-): source
Input signal		0/4 ... 20 mA
Voltage drop		SL2: 1a(+), 1b(-), 7a(-): ≤ 6.1 V at 20 mA
Short-circuit current		SL2: 5a(+), 5b(-): 25 mA
Input resistance		SL2: 5a(+), 5b(-): max. 500 Ω (BRAIN) (250 Ω load)
Available voltage		SL2: 5a(+), 5b(-): ≥ 16 V at 20 mA , ≥ 18.5 V at 4 mA
<b>Output</b>		
Connection side		control side
Connection		SL1: 8a(+), 7a(-), channel 1: source and sink SL1: 10a(+), 9a(-), channel 2: source and sink
Load		channel 1: 0 ... 500 Ω (20 mA)/> 1 MΩ (5 V) channel 2: 0 ... 500 Ω (20 mA)/> 1 MΩ (5 V)
Output signal		0/4 ... 20 mA or 0/1 ... 5 V
Ripple		max. 50 μA <sub>rms</sub>
<b>Transfer characteristics</b>		
Deviation		$I_{out} < 20 \mu A$ (0.1 %); $V_{out} < 10 \text{ mV}$ (0.2 %) incl. calibration, linearity, hysteresis and fluctuation of supply voltage, at 20 °C (68 °F), 0/4 ... 20 mA, 0/1 ... 5 V
Influence of ambient temperature		current output: 0.25 μA/K voltage output: 80 μV/K
Frequency range		field side into the control side: bandwidth with 0.5 V <sub>pp</sub> signal 0 ... 6 kHz (-3 dB) control side into the field side: bandwidth with 0.5 V <sub>pp</sub> signal 0.3 ... 6 kHz (-3 dB)
Settling time		6 ms
Rise time/fall time		2 ms
<b>Galvanic isolation</b>		
Output/power supply		functional insulation, rated insulation voltage 50 V AC
Output/Output		functional insulation, rated insulation voltage 50 V AC
<b>Indicators/settings</b>		
Display elements		LED
Control elements		DIP switch
Factory setting		output: current source
Configuration		via DIP switches
Labeling		space for labeling at the front
<b>Directive conformity</b>		
Electromagnetic compatibility		
Directive 2014/30/EU		EN 61326-1:2013 (industrial locations)
<b>Conformity</b>		
Electromagnetic compatibility		NE 21:2012 EN 61326-3-2:2008
Degree of protection		IEC 60529:2001
Protection against electrical shock		UL 61010-1:2012
<b>Ambient conditions</b>		
Ambient temperature		-20 ... 60 °C (-4 ... 140 °F)
<b>Mechanical specifications</b>		
Degree of protection		IP20
Mass		approx. 105 g
Dimensions		12.5 x 106 x 128 mm (0.5 x 4.2 x 5.1 inch) (W x H x D)

## Technical Data

Mounting		on termination board
Coding		pin 2 and 3 trimmed For further information see system description.
<b>Data for application in connection with hazardous areas</b>		
EU-type examination certificate		BASEEFA 13 ATEX 0075 X
Marking		Ⓜ II (1)G [Ex ia Ga] IIC Ⓜ II (1)D [Ex ia Da] IIIC Ⓜ I (M1) [Ex ia Ma] I
Input		Ex ia
Supply		
Maximum safe voltage	$U_m$	250 V (Attention! The rated voltage can be lower.)
Equipment		SL2: 5a(+), 5b(-)
Voltage	$U_o$	25.2 V
Voltage	$U_q$	28.2 V
Current	$I_o$	93 mA
Power	$P_o$	656 mW
Internal capacitance	$C_i$	12 nF
Internal inductance	$L_i$	0 mH
Equipment		SL2: 1a(+), 1b(-), 7a(-)
Voltage	$U_i$	30 V
Current	$I_i$	115 mA
Power	$P_i$	700 mW
Voltage	$U_o$	5 V
Current	$I_o$	6.8 mA
Power	$P_o$	1.6 mW
Internal capacitance	$C_i$	12 nF
Internal inductance	$L_i$	0 mH
Output		
Maximum safe voltage	$U_m$	250 V (Attention! The rated voltage can be lower.)
Certificate		BASEEFA 13 ATEX 0076 X
Marking		Ⓜ II 3G Ex nA IIC T4 Gc
Galvanic isolation		
Input/Output		safe electrical isolation acc. to IEC/EN 60079-11, voltage peak value 375 V
Input/power supply		safe electrical isolation acc. to IEC/EN 60079-11, voltage peak value 375 V
Directive conformity		
Directive 2014/34/EU		EN IEC 60079-0:2018+AC:2020 , EN 60079-11:2012 , EN 60079-15:2010
<b>International approvals</b>		
UL approval		E106378
Control drawing		116-0349 (cULus)
IECEx approval		
IECEx certificate		IECEx BAS 13.0042X
IECEx marking		[Ex ia Ga] IIC , [Ex ia Da] IIIC , [Ex ia Ma] I
<b>General information</b>		
Supplementary information		Observe the certificates, declarations of conformity, instruction manuals, and manuals where applicable. For information see <a href="http://www.pepperl-fuchs.com">www.pepperl-fuchs.com</a> .

## Assembly

### Front view

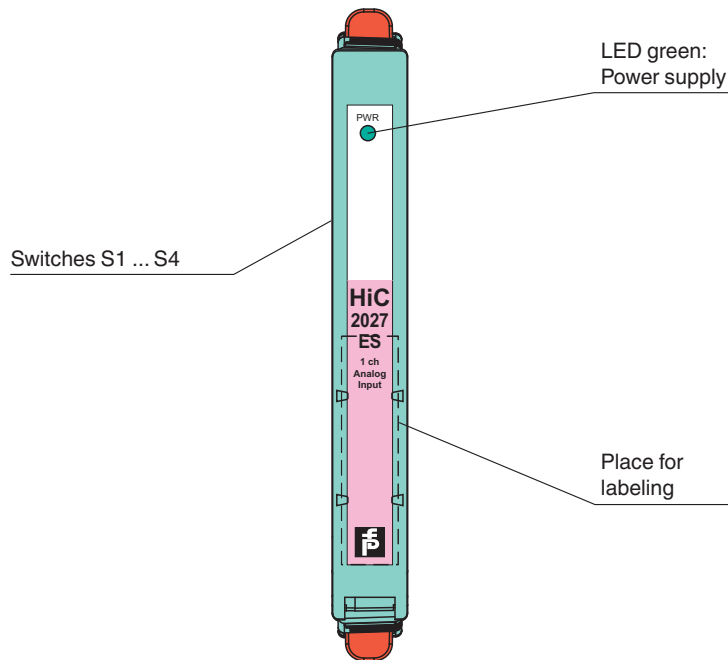

## Safety Information

The pins for this device are trimmed to polarize it according to its safety parameter. Do not change this setting!  
For further information see system manual.

Both output loads must be connected to ensure complete and correct operation within the technical specification.

## Configuration

Configure the device in the following way:

- Push the red Quick Lok Bars on each side of the device in the upper position.
- Remove the device from termination board.
- Set the switches according to the figure in the **Configuration** section.

**Configuration**

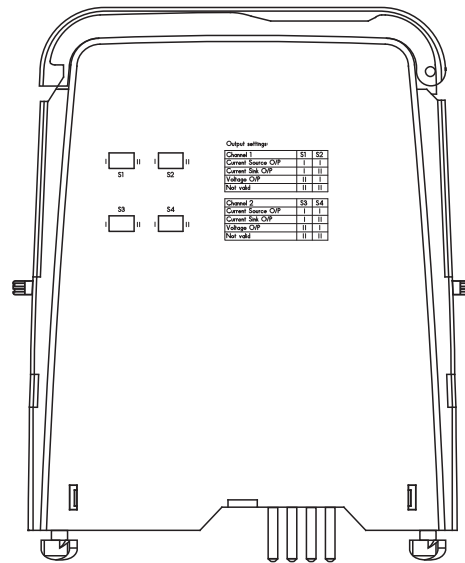

**Output switch settings**

Channel 1	S1	S2
Current source output	I	I
Current sink output	I	II
Voltage output	II	I
Not valid	II	II

Channel 2	S3	S4
Current source output	I	I
Current sink output	I	II
Voltage output	II	I
Not valid	II	II

Factory settings: current source output, for both channels.

Release date: 2023-08-07 Date of issue: 2023-08-07 Filename: 286744\_eng.pdf