



Com Unit for MODBUS RTU LB8107H0706

- Interface between the I/O modules and the PCS/PLC
- Com unit for 80 analog or 184 digital channels
- Communication via MODBUS RTU
- Mounting in Zone 2, Class I/Div.2 or in the safe area
- HART communication via service bus
- Configuration via FDT 1.2 DTM
- Non-volatile memory for configuration and parameter settings
- Self configuration in redundant systems
- Permanently self-monitoring
- Outputs drive to safe state in case of failures
- Module can be exchanged under voltage



Function

The MODBUS RTU com unit forms the interface between the I/O modules on the backplane and the process control system. It supports all single width and dual width I/O modules. Thereby signals from NAMUR sensors, mechanical contacts, high-power solenoid drivers, power relays, sounders, and alarm LEDs are transported to the higher-level bus system. The com unit can be easily configured via DTM and supports redundancy as well as HART.

Wiring Diagram

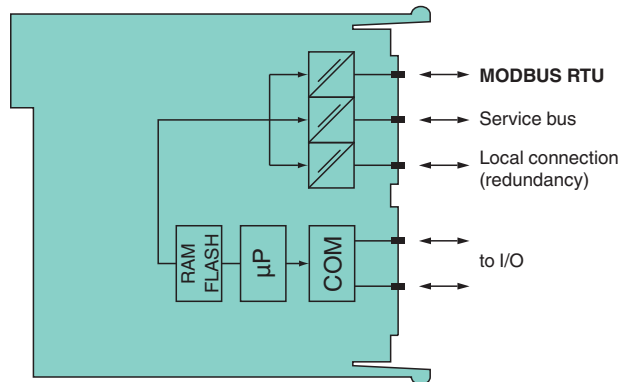

Zone 2
Div. 2

Technical Data

Supply		
Connection		backplane bus
Rated voltage	U _r	5 V DC , only in connection with the power supplies LB9***
Power dissipation		1.8 W
Power consumption		1.8 W
Fieldbus connection		
Fieldbus type		MODBUS RTU
MODBUS RTU		
Connection		9-pin Sub-D socket via backplane
Baud rate		max. 38.4 kBit/s
Number of stations per bus line		max. 245 (MODBUS), max. 119 (service bus)

Technical Data

Number of channels per station	max. 80 analog, max. 184 digital (standard configuration)
Number of stations per bus segment	max. 31 (RS-485 standard)
Number of repeaters between Master and Slave	max. 3
Supported I/O modules	all LB remote I/O modules
Bus length	max. 1200 m (FOL, 38.4 kBd), max. 1200 m (copper cable, 38.4 kBd)
FOL (fiber optic link)	additional hardware required
Addressing	via configuration software
MODBUS address	standard compliant (factory standard setting: 126)
Service bus address	max. 119 , redundancy address = base + 128 (automatic)
HART communication	via service bus
Redundancy	system dependent
Internal bus	
Connection	backplane bus
Redundancy	via backplane
Indicators/settings	
LED indication	LED P: (power supply): On = operating, fast flash = cold start LED 1: (collective alarm): On = internal fault, flashing = no fieldbus connection LED 2: (operating mode): flashing 1 (1:1 ratio) = active, normal operation; flashing 2 (7:1 ratio) = active, simulation LED 3: (status fieldbus): flashing = fieldbus receive channel active LED 4: (status fieldbus): flashing = fieldbus response channel active LED 5: (status service bus): flashing = service bus receive channel active LED 6: (status service bus): flashing = service bus response channel active
Directive conformity	
Electromagnetic compatibility	
Directive 2014/30/EU	EN 61326-1
Conformity	
Electromagnetic compatibility	NE 21
Degree of protection	IEC 60529
Fieldbus standard	IEC 61158-2
Environmental test	EN 60068-2-14
Shock resistance	EN 60068-2-27
Vibration resistance	EN 60068-2-6
Damaging gas	EN 60068-2-42
Relative humidity	EN 60068-2-78
Ambient conditions	
Ambient temperature	-20 ... 60 °C (-4 ... 140 °F)
Storage temperature	-40 ... 85 °C (-40 ... 185 °F)
Relative humidity	95 % non-condensing
Altitude	max. 2000 m
Shock resistance	shock type I, shock duration 11 ms, shock amplitude 15 g, number of shocks 18
Vibration resistance	frequency range 10 ... 150 Hz; transition frequency: 57.56 Hz, amplitude/acceleration ± 0.075 mm/1 g; 10 cycles frequency range 5 ... 100 Hz; transition frequency: 13.2 Hz amplitude/acceleration ± 1 mm/0.7 g; 90 minutes at each resonance
Damaging gas	designed for operation in environmental conditions acc. to ISA-S71.04-1985, severity level G3
Mechanical specifications	
Degree of protection	IP20 (module) , mounted on backplane
Connection	via backplane
Mass	approx. 120 g
Dimensions	32.5 x 100 x 102 mm (1.28 x 3.9 x 4 inch)
Data for application in connection with hazardous areas	
Certificate	PF 08 CERT 1234 X
Marking	Ⓜ II 3 G Ex nA IIC T4 Gc

Technical Data

Directive conformity	
Directive 2014/34/EU	EN IEC 60079-0:2018+AC:2020 , EN 60079-15:2010
International approvals	
ATEX approval	PF 08 CERT 1234 X
UL approval	E106378
IECEX approval	
IECEX certificate	IECEX BVS 09.0037X
IECEX marking	Ex nA IIC T4 Gc
General information	
System information	The module has to be mounted in appropriate backplanes (LB9***) in Zone 2 or outside hazardous areas. Here, observe the corresponding declaration of conformity. For use in hazardous areas (e. g. Zone 2, Zone 22 or Div. 2) the module must be installed in an appropriate enclosure.
Supplementary information	EC-Type Examination Certificate, Statement of Conformity, Declaration of Conformity, Attestation of Conformity and instructions have to be observed where applicable. For information see www.pepperl-fuchs.com .

Assembly

Front view

