

SMART Current Driver KFD2-SCD2-Ex1.LK

- 1-channel isolated barrier
- 24 V DC supply (Power Rail)
- Current output up to 650 Ω load
- HART-IP and valve positioner
- Line fault detection (LFD)
- Accuracy 0.1 %
- Up to SIL 2 (SC 3) acc. to IEC/EN 61508



Function

This isolated barrier is used for intrinsic safety applications. The device drives SMART I/P converters, electrical valves, and positioners in hazardous areas. Digital signals are superimposed on the analog values at the field side or control side and are transferred bi-directionally. Current transferred across the DC/DC converter is repeated at terminals 1 and 2. Terminals 2 and 3 are used when no short circuit detection is required. An open or short field circuit presents a high impedance to the control side to allow alarm conditions to be monitored by the control system. If the HART communication resistance in the loop is too low, the internal resistance can be used. Test sockets for the connection of HART communicators are integrated into the terminals of the device. A fault is signaled by LEDs and a separate collective error message output.

Connection

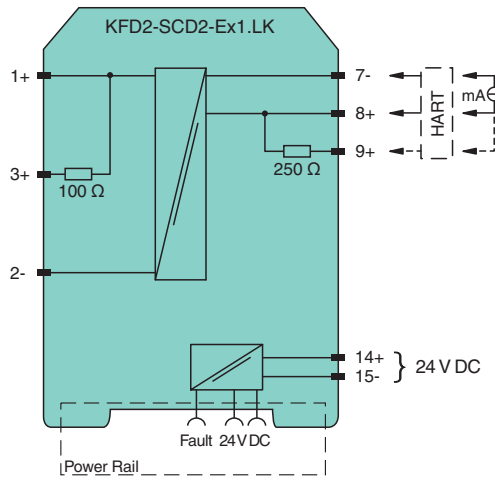
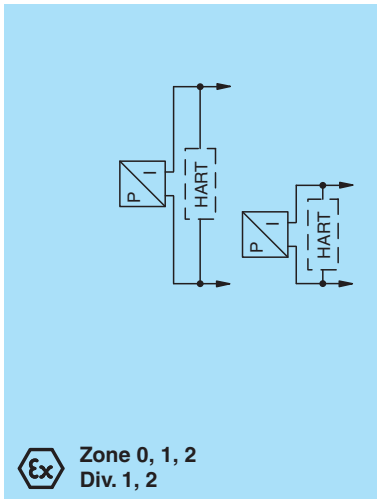

Technical Data

General specifications	
Signal type	Analog output
Functional safety related parameters	
Safety Integrity Level (SIL)	SIL 2
Systematic capability (SC)	SC 3
Supply	
Connection	Power Rail or terminals 14+, 15-
Rated voltage	U_r 19 ... 30 V DC
Ripple	≤ 10 %

Release date: 2025-03-06 Date of issue: 2025-03-06 Filename: 295086_eng.pdf

Technical Data

Rated current	I_r	$\leq 30 \text{ mA at } 24 \text{ V}$
Power dissipation		$\leq 600 \text{ mW at } 20 \text{ mA and } 500 \Omega \text{ load}$
Power consumption		$\leq 700 \text{ mW}$
Input		
Connection side		control side
Connection		terminals 7-, 8+, (9+)
Input signal		4 ... 20 mA , limited to approx. 30 mA
Input voltage		open loop voltage of the control system $\leq 30 \text{ V}$
Voltage drop		approx. 6 V at 20 mA
Input resistance		field wiring open circuit : $> 100 \text{ k}\Omega$ field wiring $< 50 \Omega$: $> 100 \text{ k}\Omega$ when using terminals 1 and 2
Output		
Connection side		field side
Connection		terminals 1+, 2- terminals 3+, 2- (no short circuit detection)
Voltage		$\geq 13 \text{ V at } 20 \text{ mA}$
Current		4 ... 20 mA
Load		100 ... 650 Ω , for terminals 1, 2 0 ... 550 Ω , for terminals 2, 3
Ripple		20 mV rms
Line fault detection		breakage, load $> 100 \text{ k}\Omega$, short-circuit, load $< 50 \Omega$
Fault indication output		
Output type		open collector transistor (internal fault bus)
Transfer characteristics		
Deviation		at 20 °C (68 °F), 4 ... 20 mA $< 0.1 \%$ of full scale, incl. non-linearity and hysteresis
Influence of ambient temperature		$< 2 \mu\text{A/K}$ (-20 ... 70 °C (-4 ... 158 °F)); $< 4 \mu\text{A/K}$ (-40 ... -20 °C (-40 ... -4 °F))
Frequency range		field side into the control side: bandwidth with 0.5 V_{pp} signal 0 ... 3 kHz (-3 dB) control side into the field side: bandwidth with 0.5 V_{pp} signal 0 ... 3 kHz (-3 dB)
Rise time		10 to 90 % $\leq 10 \text{ ms}$
Galvanic isolation		
Input/Output		basic insulation according to IEC/EN 61010-1, rated insulation voltage 300 V_{eff}
Input/power supply		basic insulation according to IEC/EN 61010-1, rated insulation voltage 300 V_{eff}
Output/power supply		reinforced insulation according to IEC/EN 61010-1, rated insulation voltage 300 V_{eff}
Indicators/settings		
Display elements		LEDs
Labeling		space for adhesive label at the front
Directive conformity		
Electromagnetic compatibility		
Directive 2014/30/EU		EN 61326-1:2013 (industrial locations)
Conformity		
Electromagnetic compatibility		NE 21:2017 EN 61326-3-2:2018
Degree of protection		IEC 60529
Protection against electrical shock		UL 61010-1:2012
Ambient conditions		
Ambient temperature		-40 ... 70 °C (-40 ... 158 °F)
Mechanical specifications		
Degree of protection		IP20
Connection		screw terminals
Mass		approx. 115 g
Dimensions		20 x 124 x 115 mm (0.8 x 4.9 x 4.5 inch) (W x H x D) , housing type B2
Mounting		on 35 mm DIN mounting rail acc. to EN 60715:2001
Data for application in connection with hazardous areas		
EU-type examination certificate		BAS 00 ATEX 7240 X

Technical Data

Marking		Ⓜ II (1)G [Ex ia Ga] IIC Ⓜ II (1)D [Ex ia Da] IIIC Ⓜ I (M1) [Ex ia Ma] I
Output		Ex ia, Ex iaD
Voltage	U_o	25.2 V
Current	I_o	93 mA
Power	P_o	585.3 mW
Internal capacitance	C_i	1.05 nF
Internal inductance	L_i	0
Supply		
Maximum safe voltage	U_m	250 V _{rms} (Attention! The rated voltage can be lower.)
Input		
Maximum safe voltage	U_m	250 V _{rms} (Attention! The rated voltage can be lower.)
Certificate		FIDI 22 ATEX 0002 X
Marking		Ⓜ II 3G Ex ec IIC T4 Gc
Galvanic isolation		
Input/Output		safe electrical isolation acc. to IEC/EN 60079-11, voltage peak value 375 V
Output/power supply		safe electrical isolation acc. to IEC/EN 60079-11, voltage peak value 375 V
Directive conformity		
Directive 2014/34/EU		EN IEC 60079-0:2018 , EN 60079-11:2012 , EN IEC 60079-7:2015+A1:2018
International approvals		
UL approval		E106378
Control drawing		116-0345 (cULus)
IECEX approval		
IECEX certificate		IECEX BAS 04.0014X
IECEX marking		[Ex ia Ga] IIC , [Ex ia Da] IIIC , [Ex ia Ma] I Ex ec IIC T4 Gc
General information		
Supplementary information		Observe the certificates, declarations of conformity, instruction manuals, and manuals where applicable. For information see www.pepperl-fuchs.com .

Assembly

Front view

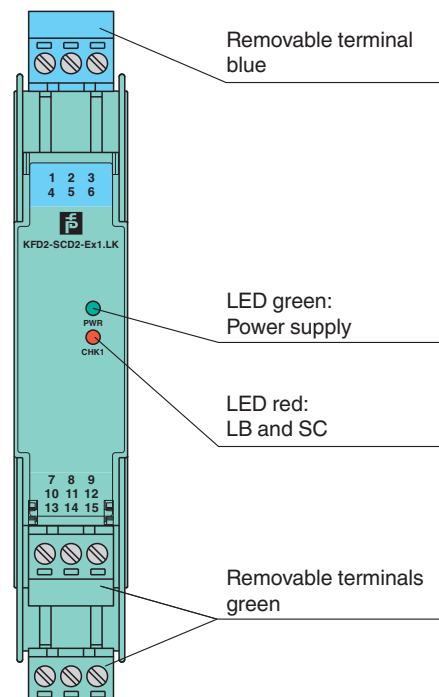

Operation

Lead monitoring, input characteristics

During lead breakage ($> 16\text{ V}$) in the field the input resistance is $> 100\text{ k}\Omega$, the field current is 0 mA , the input current is $< 0.3\text{ mA}$ and the red LED is flashing.

During short circuit ($< 50\ \Omega$) in the field the input resistance is $> 100\text{ k}\Omega$, the input current is $< 100\ \mu\text{A}$, the field current is $< 2.5\text{ mA}$ and the red LED is flashing.

The voltage drop at the current input (terminals 7-, 8+) is lower than 6 V .